

MTP302i-SIL

Loop-powered transmitter for thermocouple type K (NiCr-Ni)
with 2nd output for extended measuring range



Properties

- 2-wire temperature transmitter for DIN rails
- Two temperature ranges
- Galvanically isolated TC-inputs with cold-junction compensation
- Signal pass-through time:
 - without Butterworth filter ≤ 3 ms
 - with Butterworth filter ≤ 38 ms
- Installation in zone 1 or 2
- Intrinsic safety according to EN IEC 60079-11
- SIL 2 according to IEC 61508 but not for the 2nd output
- Error indication according to NAMUR NE 43
- LED status indication



Description

The TC transmitter must be intrinsically safe supplied by a two-channel repeater power supply. The two power supply circuits must be electrically separated.

The 2-wire temperature transmitter **MTP302i-SIL-*** has one, the **MTP302-SIL-2*** two galvanic isolated thermocouple-inputs. They have been specially developed for rapid temperature measurement in the hazardous area. Each TC-input is equipped with a Pt100 sensor for the cold-junction compensation.

* Thermocouple type



WARNING: Explosion hazard

The device is an intrinsically safe electrical equipment and can be used in zone 1 or zone 2, if the conditions of EN IEC 60079-0 are met.

When installing and operating the device, the applicable safety directives (including national safety directives), accident prevention regulations, as well as general technical regulations, must be observed.

Observe the safety regulations and installation notes on page 6.

Table of Contents

1	Technical Data	3
2	Safety Regulations and Installation Notes	7
3	General information for construction and operation	8
4	Installation	9
5	Comparison of Safety Data	9
6	Principle of Function	10
7	Safety Function	11
8	Safety Applications for SIL 2	12
9	PFD Calculations	13
10	Appendix_1: EU Declaration of Conformity	
11	Appendix_2: EU Examination Certificate	

1 Technical Data

Ex-Certificate	 BVS 08 ATEX E 082 X Issue 1 II 2 (1) G Ex ib [ia Ga] IIC T4 Gb
Conformance with	EN IEC 60079-0:2018 General requirements EN 60079-11:2012 Intrinsic safety "i"
Functional Safety (SIL)	SIL 2 according to IEC 61508

Safety specifications for intrinsically safe circuits

Power supply circuits - Ex ib IIC (terminals 1 and 4, terminals 13 and 16)

Voltage	Ui	28 Vdc
Current	Ii	95 mA
Power	Pi	655 mW
Effective inner capacity	Ci	26 nF
Effective inner inductivity	Li	negligible

Thermocouple inputs - Ex ia IIC and Ex ib IIC (terminals 5 and 8, 9 and 12)

Voltage	Uo	1 Vdc
Current	Io	1.8 mA
Power	Po	0.5 mW
Permissible outer capacity	Co	10 µF
Permissible outer inductivity	Lo	100 mH

Input signals (terminals 5+ 8 and 9+ 12)

Thermocouple type K	see nameplate
Measuring range_1 (can't be changed)	0 - 400 °C
Measuring range_2 (can't be changed)	0 - 1200 °C
Cold-junction compensation with Pt100 sensor (see Fig. 4)	-10 ...+ 70°C

mA output signal_1 (terminals 1+ 4) and mA output signal_2 (terminals 13 + 16)

Current proportional to temperature I_o	4 ... 20 mA
Maximum current I_{max}	< 24 mA
Behavior by failure (according to NE 43) I_{fail}	≤ 3.6 mA

Status indicator (power supply respectively mA signal)

Green LED	luminosity corresponds to 4 ... 20 mA
Behavior by failure	off

General data

Signal pass-through time

Input to output without Butterworth filter (OFF, Fig. 2)	≤ 3 ms
Input to output with Butterworth filter (ON, Fig. 2)	≤ 38 ms (default)

Transmission error

Typical	< 0.05 % (of final value)
---------	---------------------------

Temperature coefficient

Typical	< 0.05 %/10
---------	-------------

Pt100 sensor error

DIN IEC 751, Class B by 0°C	< 0.
-----------------------------	------

Cold-junction compensation error

Temperature range 0°C to +50°C	< 0.
Temperature range -10°C to +70°C	< 0.

Linearization error

Typical	< 0.
---------	------

Measured value deviation

Typical	< 0.6°C at
---------	------------

Electric insulation

Tested according to norms & rules EN 60079-11

Electromagnetic compatibility

Tested according to norms & rules EN 61326-3-2

Current loop supply

Voltage range ($R_{L,oad} = 70 \Omega \dots 800 \Omega$)	12.5 ... 28 V
Current range	> 3.5 ... < 24 mA

Power dissipation

Minimum (12.5 V x 4 mA)	50 mW
Maximum (28 V x 20 mA)	560 mW

Ambient temperature

Operation	-10°C to +70°C
Storage/transport	-20°C to +80°C

Humidity

Permissible operating humidity (no condensing)	10 % ... 95 %
--	---------------

Housing

Material	Polyamide
Color	light grey
Degree of protection	IP20
Width x length x height (with connection terminal blocks)	22.5 x 115 x 108 mm
Inflammability class according to UL 94	V0
Housing type for mounting	35 mm DIN rails
Weight with terminal blocks	approx. 200 g

Connection data

Solid (minimum/maximum)	0.2 mm ² /2.5 mm ²
Stranded wire (minimum/maximum)	0.2 mm ² /2.5 mm ²
AWG/kcmil (minimum/maximum)	24/14
Stripping length	7 mm
Connection method	pluggable screw connection
Tightening torque	0.5 ... 0.6 Nm

Installation

Safe area:	Install the device in a clean and dry environment.
Ex area (zone 1):	The enclosure must comply with at least IP54 protection and meet the Requirements of IEC/EN 60079-0

Dimensions

Fig. 1

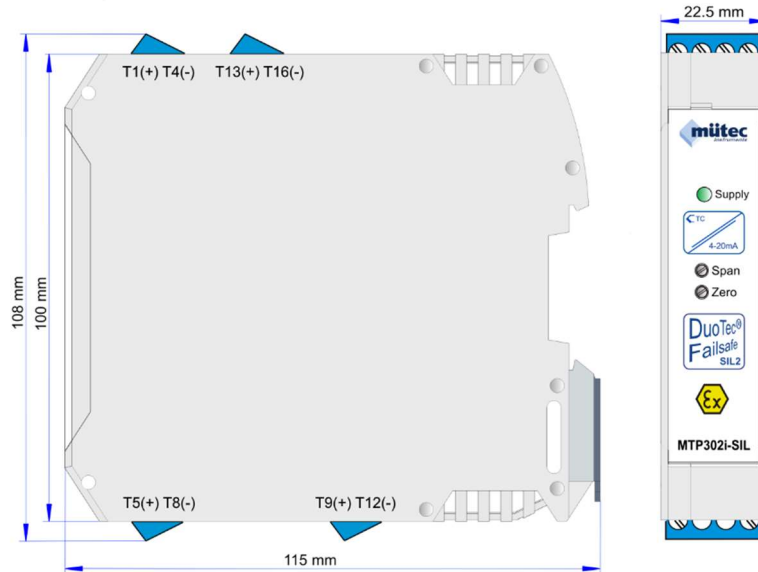

Nameplate

Fig. 2

Terminal 9...12	TC 2	Mütec Instruments GmbH Bei den Kämpen 26 D-21220 Seevetal		Terminal 13...16
		Temperature Transmitter MTP 302i-SIL-2K		
CE 0158 II 2 (1) G Ex ib [ia Ga] IIC T4 Gb BVS 08 ATEX E 082 X		Loop 2* Supply: 13(+)/16(-) PE: 14/15		Terminal 1...4
Electrical data: SEE MANUAL Made in Germany				
Terminal 5...8	TC 1	TC Type: K, 0 to +400°C	T _{amb} : -10°C to +70°C	Loop 1 Supply: 1(+)/4(-) PE: 2/3
		Serial-No.: 0024	Date: 2351	
		TAG No.: < leer >		
* note: Range Loop 2 = 3 x Range Loop 1				

Adjustment for ZERO (4 mA) and SPAN (20 mA)

Fig. 3

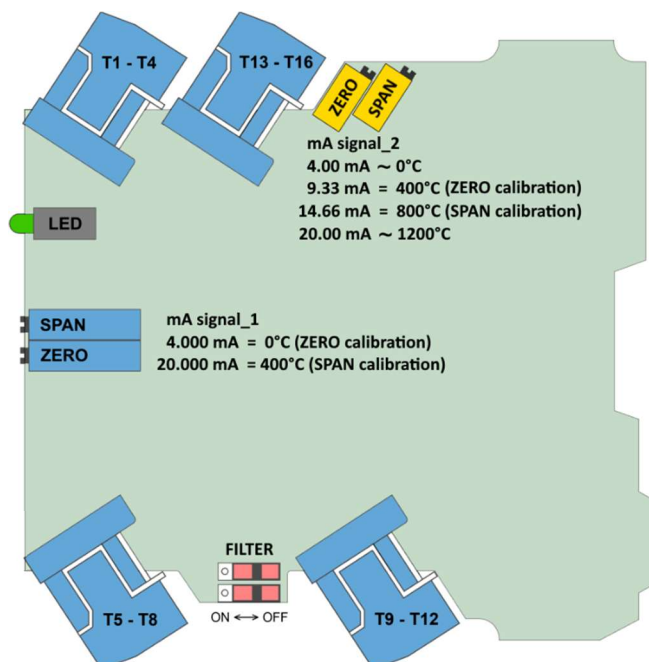

Error of cold-junction temperature compensation between -10°C to 70°C

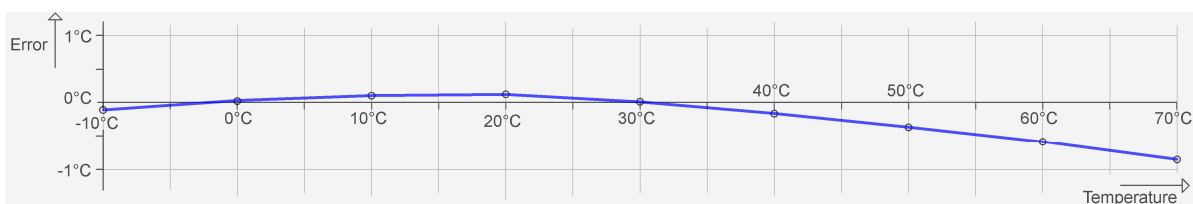

Fig. 4

Mounting and removal

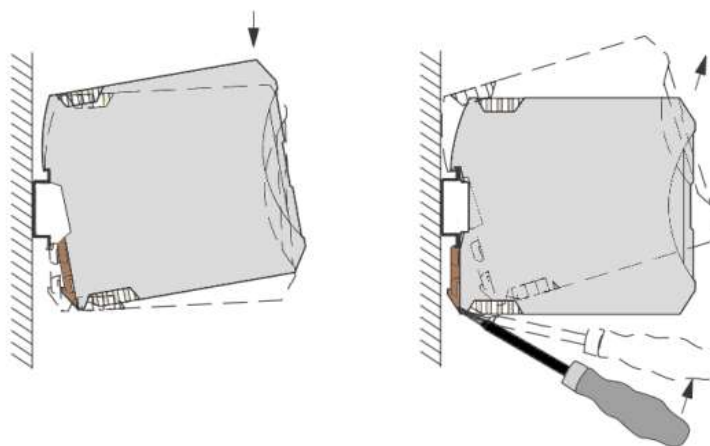

Fig. 5

Mount the module on a 35 mm DIN rail according to EN 60715
 Install the module in a suitable housing to meet the requirements for the protection class

- Mounting: Snap-on foot below (left part of drawing)
- Removal: With a screwdriver (right part of drawing)



Before start up, check the correct wiring and labeling of the intrinsically safe circuits.

Connecting the cables: Permissible cable cross-section are 0.2 mm² to 2.5 mm²
 Stranded wires provided with ferrules.

Screw connection: Insert the wire into the corresponding connection terminal block and use a screwdriver to tighten the screw in the opening above the connection terminal block.

2 Safety Regulations and Installation Notes

Follow the installation instructions:



NOTE: Installation, operation, and maintenance may only be carried out by qualified specialist personnel.

When installing and operating the device, follow the applicable safety directives (including national safety directives), accident prevention regulations, as well as general technical regulations,



NOTE: The circuits inside the device must not be accessed.

Do not repair the device itself but replace it with an equivalent device. Repairs may only be carried out by the manufacturer.



NOTE: The device is suitable for IP20 degree of protection if:

- It is installed outside potentially explosive area
- The environment is clean and dry

Install the device in a suitable enclosure with a suitable degree of protection in accordance with EN IEC 60079-0 to protect against mechanical and electrical damage. The safety-relevant data can be found in the operating instructions and in the ATEX certificate (EC type-examination certificate, other approvals, if necessary).

Safety regulations for installation in potentially explosive areas and regulations for intrinsically safe circuits:



WARNING: Explosion hazard

When carrying out measurements on the intrinsically safe side, be sure to observe the relevant regulations regarding the connection of intrinsically safe equipment. Only use devices approved for use in intrinsically safe circuits.



WARNING: Explosion hazard

If the device has been used in non-intrinsically safe circuits, it must not be used again in intrinsically safe circuits.

Clearly label the module as being non-intrinsically safe.

Special conditions for installation and operation (X-marking)



Warning: Risk of explosion

The device is an intrinsically safe equipment of protection class "Ex-i" and must be installed outside a potentially explosive area.



Installation in Zone 1 or Zone 2

Install the device in a suitable enclosure with at least IP54 protection and in accordance with EN IEC 60079-0

Installation in areas with a danger of dust explosions:



WARNING: Explosion hazard

The device is not designed for installation in areas with a danger of dust explosions.

Connection to the intrinsically safe circuit in areas with a danger of dust explosions (zones 20, 21, and 22) is only permitted if the equipment connected to this circuit is approved for this zone (e.g., category 1D, 2D or 3D).

3 General information for construction and operation

Marking according to Directive 2014/34/EU:

Testing center _____ **0158**  **II (2) G**

Device Group _____

Associated equipment with external circuits
for connection to category 2 devices _____

for explosive mixtures of air and flammable
Gassing, vapouring or fogging _____

Identification of the type of protection:

_____ **[Ex ia Ga] IIC**

associated electrical operation medium
according to European standard _____

Explosion protection _____

EPL (Equipment Protection Level) _____

Equipment Group _____

Other safety precautions

The device must be taken out of service and secured against unintentional operation, if it must be assumed that safe operation is no longer possible. Reasons for these assumptions can be:

- Visible damage to the device
- Failure of electrical function
- Longer storage at temperatures above 85 °C
- Heavy transport loads

Before the device is put back into operation, a professional piece test in accordance with DIN must be carried out according to EN 61010, Part 1. This test should definitely be carried out by the manufacturer. Repair work on Ex equipment may only be carried out in compliance with §9 of the Ex-Ordinance (Elex V).

Devices with intrinsically safe circuits must never be connected to non-intrinsically safe circuits. If Ex equipment is to be operated on non-intrinsically safe circuits, they must be specially marked and all Ex-labels must be removed at all costs so that these devices are not later used again for intrinsically safe circuits. A subsequent inspection of the devices for compliance with the conditions for explosion protection is only possible with a disproportionately high effort, even at the manufacturer's site, and is therefore usually rejected.

4 Installation



NOTE: Electrostatic discharge

The device contains components that can be damaged or destroyed by electrostatic discharge. When handling the device, observe the necessary safety precautions against electrostatic discharge (ESD) according to EN 61340-5-1 and EN 61340-5-2.

Basic circuit diagram of the MTP302i-SIL-K

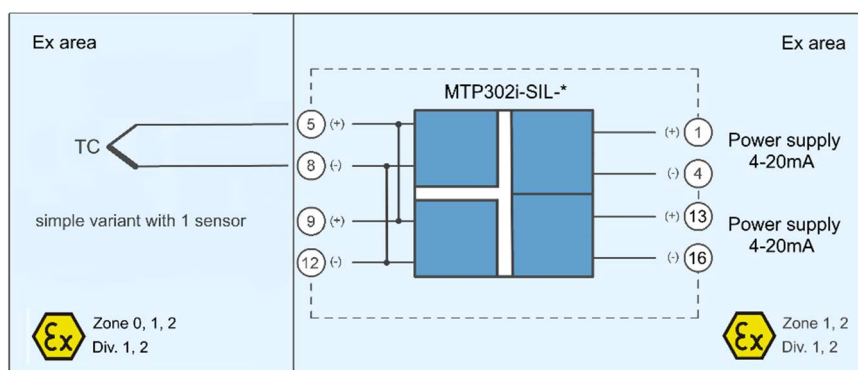

Fig. 6

Measuring input (intrinsically safe):

Thermocouple with connection to terminal 5/+ and

Attention: The terminals 5+8 and 9+12 are already connected internally!

Power supply/output signal_1 (intrinsically safe):

Repeater power supply with connection to terminal 1/+ and 4/-

Power supply/output signal_2 (intrinsically safe):

Repeater power supply with connection to terminal 13/+ and 16/-

5 Comparison of Safety Data

WARNING: Explosion hazard

Compare the safety data before connecting a device located in the Ex-i area to the MTP300i-SIL-2*.

Safety data for

MTP302i-SIL-K:

U_i, I_i, P_i, L_i, C_i

Power supply:

U_o, I_o, P_o, L_o, C_o

For the values for U_o, I_o, P_o, L_o and C_o please refer to "Safety data according to Ex for intrinsically safe circuits" on page 2.

Ex-i requirements (simple circuits

$$U_i \geq U_o$$

$$I(i) \geq I_o$$

$$P(i) \geq P_o$$

$$L_i + L_{(c)} \leq L_o \quad (L_c \text{ is depend on the cables/lines used})$$

$$C_i + C_{(c)} \leq C_o \quad (C_c \text{ is depend on the cables/lines used})$$

6 Principle of Function:

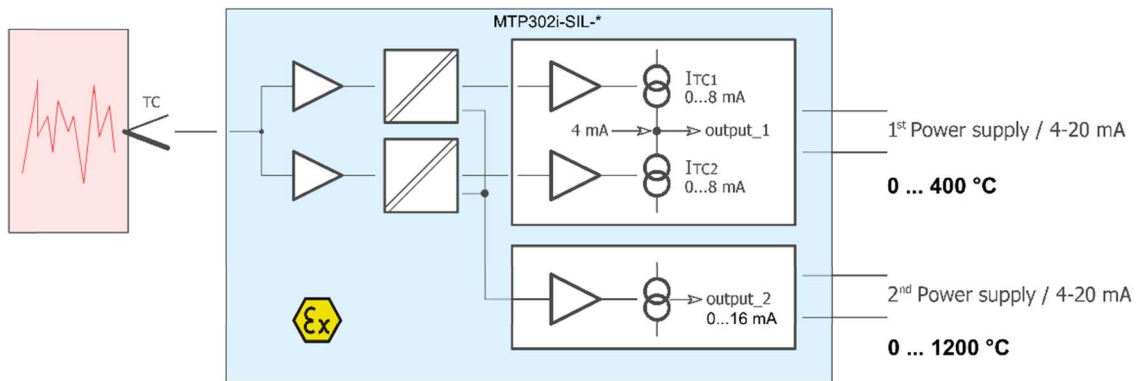

Fig. 7

The MTP302i-SIL-K has two input channels connected internally in parallel. Two electrically isolated mA sources are controlled synchronously and form the sum value for the 4-20 mA signal in the supply circuit. The two-channel structure of the transmitter guarantees a high degree of Functional Safety. The function groups of the internal circuit and the measuring circuits with the thermocouple and extension wires are subject of a continuous self-diagnosis and guarantees a high degree of Functional Safety with a λ_{du} of 4,7 FIT.

In the event of an error, the output signal is reduced to < 3.6 mA according to NE43 (NAMUR recommendation)

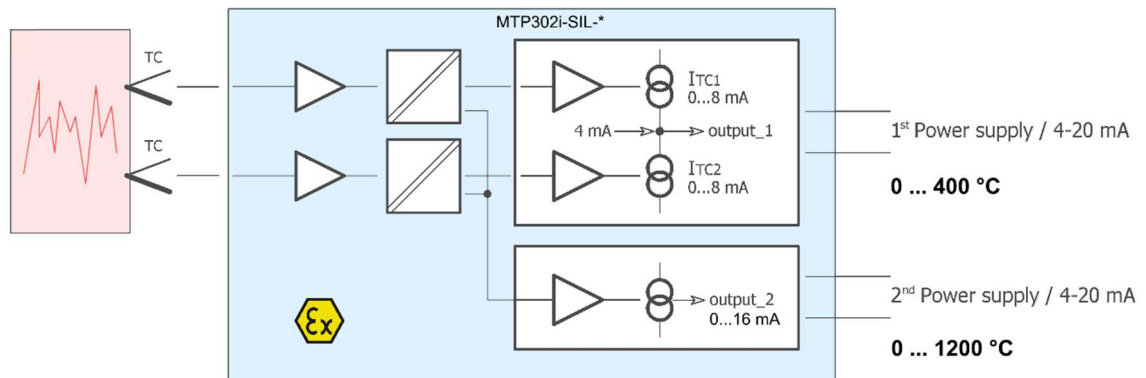

Fig. 8

The MTP302i-SIL-2K has two galvanically isolated input channels for thermocouples. Two electrically isolated mA-sources for the output are controlled synchronously and form the sum value for the 4-20 mA signal in the supply circuit.

The two-channel structure of the temperature transmitter guarantees a high degree of functional safety ($\lambda_{du} = 4.7 \text{ FIT}$).

In the event of an error, the output signal is reduced to $< 3.6 \text{ mA}$ according to NE43 (NAMUR recommendation).

7 Safety Function:

Activation of the Safety Function: $I_{(a)} \leq 3.6 \text{ mA}$

A deviation $> 5 \%$ between the two galvanic isolated temperature channels or an internal failure leads to a value reduction of the mA output ($< 3.6 \text{ mA}$). The output signal (see Fig. 7) returns after a break of about 7 to 9 seconds and the self monitoring checks again, whether the failure is still present and thus the shutdown must be repeated.

Only an external failure (thermocouple or wire break) leads to a permanent reduction of the mA-value in the supply circuit ($< 3.6 \text{ mA}$).

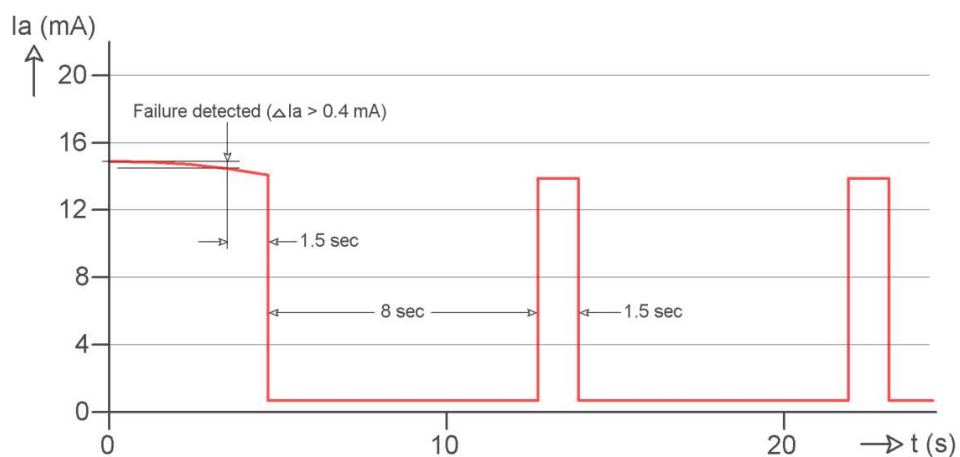

Fig. 9

Behavior of the output signal for internal errors:

- Monitoring of the two measurement channels
If the deviation exceeds the value of 5 %, the mA value of the output circuit jumps periodically to $< 3.6 \text{ mA}$.
- Monitoring of the internal supply
If the deviation exceeds the value of 5 %, the mA value of the output circuit jumps periodically to $< 3.6 \text{ mA}$.
- Monitoring of the internal supply
If the deviation exceeds the value of 5 %, the mA value of the output circuit jumps periodically to $< 3.6 \text{ mA}$.
- Monitoring of the clock
If the deviation of the clock frequency exceeds the value of 10 %, the mA value of the output circuit jumps periodically to $< 3.6 \text{ mA}$.

Behavior of the output signal for external errors of the MTP302-SIL-K:

- Sensor or cable break
The transmitter output signal is permanently limited < 3.6 mA.
- Short circuit in the measuring circuit
The mA value of the output circuit corresponds to the cold-junction temperature value of the Pt100 sensor

8 Safety Applications for SIL 2

Safety integrity requirements (see also technical report 4.139.18 / Risknowlogy)

Failure rates of temperature measurement channels:

Type B device (according to IEC/EN 61508-2), Safety Integrity Level (SIL 2)

λ_{sd}	λ_{su}	λ_{dd}	λ_{you}	SFF
0 FIT	78.5 FIT	61.3 FIT	4.7 FIT	96.8 %

λ_{su} includes failure that does not cause a spurious trip

SFF = Safe Failure Fraction

FIT = Failure In Time (1 FIT = 1 failure / 10⁹ h)

PFD_{AVG} values of MTP300i-SIL... without TC-sensor(s):

The beta factor is 2 % and was derived from IEC/EN 61508-6, Annex D

T [PROOF]	1 Year	2 Years	5 Years	10 Years	20 Years
PFD _{AVG}	5.	1.11E-04	2.77E-04	5.54E-04	1.11E-03
% SIL 2	0.56 %	1.11 %	2.77 %	5.54 %	11.07 %

PFD_{AVG} = Average value of the Probability of Failure on Demand

T [PROOF] = Proof test interval

The calculated PFD_{AVG} values are within the allowed range for SIL 2 according to table 2 of IEC/EN 61508-1, and do fulfill the requirement to not cover more than 15 % of this range after 20 years.

PFS_{AVG} for 1 Year: 2.63E-05

PFS_{AVG} = Average value of the Probability of Fail Safe

Failure limit:

The operating mode is based on low demand mode.

The proportion of MTP300i-SIL on the PFD_{AVG} of safety chain shall be not more 15 %.

Sensors (2TC)	MTP300i-SIL	Repeater power supply	Processing
35 %	15 %	35 %	15 %

Conditions:

- The failure rates of the components used remain constant throughout the period of use.
- Propagation of errors by the device in the system is not taken into consideration.
- The repair time (= replacement) should be 72 hours.
- The average temperature at which the device is to be used is +40°C. This is based on standard industrial conditions.
- The failure rates given refer to an ambient temperature of +40°C. For an ambient temperature of +60°C, you will need to multiply the failure rates by a factor of 2.5. The factor is based on empirical values gathered.

Proof test

Carry out the appropriate steps to prevent incorrect use.

An example for TC type K:

An input signal of 0...16.395 mV corresponds to a temperature range from 0 to 400°C.

The output must be set to 4.00...20.00 mA.

Setting ≤ 3.6 mA or > 22 mA verifies that the subsequent processing can provide signals outside the range.

In the event of an error, the device must be replaced by an equivalent device.

Restore the safety circuit to full functionality.

Return to normal operation.

9 PFD Calculations

Typical TC-sensor has the following failure rates:

	TC sensor without extension wire				TC sensor with extension wire			
	s [FIT]	d [FIT]	DC	SFF	s [FIT]	d [FIT]	DC	SFF
Low stress	40	9	95 %	81.63 %	381	95	95 %	80.04
High stress	787	173	95 %	81.98 %	7600	1900	95 %	80.00

Typical extension wire has the following failure rates:

	Extension wire			
	s [FIT]	d [FIT]	DC	SFF
Low stress	341	86	95 %	79.86 %
High stress	6813	1727	95 %	79.96 %

Variants (A, B, C) for the TC connection:

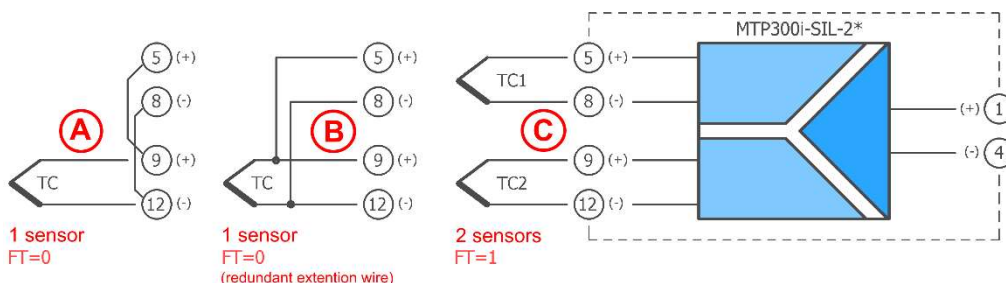

Fig. 10

A: Failure rate for 1 TC-sensor with extension wire (high stress):

MTP300i-SIL-* (terminals 5+8 and 9+12 are connected internally)

MTP300i-SIL-2* (terminals 5+8 and 9+12 are to be connected externally)

T [PROOF]	1 Year	2 Years	5 Years	10 Years	20 Years
t _(ce)	291	510	1167	2262	4452
PFD _{AVG} sensor+ wire	5.53E-04	9.69E-04	2.22E-03	4.30E-03	8.46E-03
PFD _{AVG} MTP300i-SIL	5.63E-05	1.11E-04	2.77E-04	5.54E-04	1.11E-03
PFD _{AVG} total	6.09E-04	1.08E-03	2.49E-03	4.85E-03	9.57E-03
% SIL 2	6.1 %	10.8 %	24.9 %	48.5 %	95.7 %

B: Failure rate for 1 TC sensor with redundant extension wire (high stress):

MTP300i-SIL-2* (extension wire from terminals 5+8 and 9+12 first contacted at the TC)

T [PROOF]	1 Year	2 Years	5 Years	10 Years	20 Years
t _(ce)	291	510	1167	2262	4452
PFD _{AVG} sensor	5.03E-05	8.82E-05	2.02E-04	3.91E-04	7.70E-04
t _{ge 2 extention wire}	218	364	802	1532	2992

T [PROOF]	1 Year	2 Years	5 Years	10 Years	20 Years
PFD _{AVG} redundant wire	2.55E-05	4.50E-05	1.06E-04	2.14E-04	4.56E-04
PFD _{AVG} MTP300i-SIL	5.63E-05	1.11E-04	2.77E-04	5.54E-04	1.11E-03
PFD _{AVG} total	1.32E-04	2.45E-04	5.85E-04	1.16E-03	2.33E-03
% SIL 2	1.3 %	2.5 %	5.9 %	11.6 %	23.3 %

PFD formula for single TC sensor:

$$PFD_{AVG} \text{ sensor} \approx 0.5 \times \lambda_{du} \times T_1$$

$$\lambda_{du} = (1 - DC) \times \lambda_d$$

PFD formula for dual TC sensors:

$$PFD_{AVG} \text{ Sensor} \approx 0.5 \times \beta \times \lambda_{du} \times T_1$$

$$\beta = 5 \% \text{ (for sensors)}$$

PFD formula for transmitter with the measuring circuit(s):

$$PFD_{AVG} \text{ total} = PFD_{AVG} \text{ MTP300i} + PFD_{AVG} \text{ Sensor} + \text{Wire}$$