

Your success counts

Flow rate Indicator / Totalizer

displays flow rate and total simultaneously



The F-Series is your first and safest choice for field mount indicators in safe and hazardous area applications. Especially in harsh weather conditions like rain, snow, salty atmospheres and temperatures between -40°C up to $+70^{\circ}\text{C}$ (-40°F up to 158°F).

Advantages

- Robust aluminum or stainless steel 316L field enclosure (IP67 / NEMA Type4X). It is so rugged, a truck can even stand on it!
- Intrinsically Safe available - ATEX, IECEx and CSA approval for gas and dust applications.
- Programming can be done by your own crew, with the sensible menu-driven structure, saving cost and irritation. Know one, know them all!
- Very diverse mounting possibilities: walls, pipes, panels or directly onto outdoor sensors!

Features

- Displays instantaneous flow rate, total and accumulated total.
- Large 17mm (0.67") digits for flow rate or total.
- Easy configuration with clear alphanumeric display.
- LED backlight option.
- Selectable on-screen engineering units for volumetric or mass.
- Ability to process all types of signals: Sine wave (coil), NAMUR, NPN/PNP pulse, Reed-switch, Active pulse signals, (0)4-20mA.
- Power requirements: Input loop powered, battery powered or 8 - 30V DC, 24V AC/DC and 115 - 230V AC.
- Sensor supply: 3.2 / 8.2 / 12 / 24V DC.
- Auto backup of settings and running totals.
- Explosion/flame proof available, according ATEX/IECEx.

Introduction

The F012 is a local indicator to display the actual flow rate, total and accumulated total. The total can be reset to zero by pressing the CLEAR button twice. The eleven digit accumulated total however can not be reset to zero. A wide selection of options further enhances the capabilities of this model, including Intrinsic Safety for hazardous area applications.

Display

The display has large 17mm (0.67") and 8mm (0.31") digits which can be set to show flow rate and / or totals. On-screen engineering units are easily configured from a comprehensive selection. The accumulated total can register up to 11 digits and is backed-up in EEPROM memory every minute, just as the running total. As the F012 has been designed for field mounted applications, a smart display update function has been incorporated. Related to the lower temperatures, the update frequency of the LCD is tuned automatically to achieve a readable display even at -40°C / -40°F.

Configuration

All configuration settings are accessed via a simple operator menu which can be password protected. Each setting is clearly indicated with an alphanumerical description, which avoids confusing abbreviations and baffling codes. Once familiar with one F-series product, you will be able to program all models in the series without a manual. All settings are safely stored in EEPROM memory in the event of sudden power failure.

Hazardous area

For hazardous area applications, this model is ATEX, IECEx, and CSA certified as Intrinsically Safe for gas and dust applications, with an allowed ambient temperature of -40°C to +70°C (-40°F to +158°F). A flame proof Ex d enclosure with ATEX/IECEx certification is also available.



Backlight

For those applications where readability during day and night is an issue, a white backlight is available. The intensity can be adjusted from the keyboard. The display is a transfective type, which means that a high contrast reading is guaranteed in full sunlight as well as during the night. This backlight option is also available Intrinsically Safe.

Power requirements

Several power supply options are available to power the F012 and sensor. Most popular is our battery powered version with a long life lithium battery which will last up to five years. For analog sensors, a 4 - 20mA loop powered version is available as well. A real sensor supply is offered with the 24V AC/DC or 115 - 230V AC power requirement option.



All info at a glance



Easy to install



Easy to program



Know one know them all!



Reliable



User-friendly

Overview application F012

The F-Series is your first and safest choice for field mount indicators in safe and hazardous area applications. Especially in harsh weather conditions like rain, snow, salty atmospheres and temperatures between -40°C up to +70°C (-40°F up to 158°F). Flow measurement where a local flow rate indication and totalizer function is required without re-transmission functionality. Alternative basic models F010 and F011 or more advanced F013 - F014 - F016 - F110 and higher or the D-Series DIN panel mount flow rate indicators.



Signal input

The F012 accepts most pulse and analog input signals for volumetric flow or mass flow measurement. The input signal type can be selected by the user in the configuration menu without having to adjust any sensitive mechanical dip-switches, jumpers or trimmers. The analog input is available with linear and square root calculation and even as 4 - 20mA input loop powered.

| Type of signal | Resistance | Low Pass filter (LP) | Max. frequency | Max. frequency Low Pass filter (LP) | Min. amplitude p-p | Remark |
|-------------------|----------------|----------------------|-------------------------|-------------------------------------|--------------------|-----------------------------|
| NPN | 100kΩ pull-up | 100kΩ pull-up | 6kHz Threshold 1.2V | 1.2kHz | | Open collector |
| REED | 1MΩ pull-up | 1MΩ pull-up | 600Hz Threshold 1.2V | 120Hz | | |
| PNP | 47KΩ pull-down | 100KΩ pull-down | 6kHz Threshold 1.2V | 1.2kHz | | |
| NAMUR | 820Ω pull-down | - | 4kHz | - | | External power required |
| COIL LO | - | - | | - | 90mV _{pp} | Default sensitivity |
| COIL-HI | | | | | 20mV _{pp} | Sensitive for interference! |
| COIL-HI (Type ZF) | - | - | - | - | 10mV _{pp} | |
| COIL-HI (Type ZG) | | | | | 5mV _{pp} | |
| ACTIVE 8.2V DC | 3K9Ω | | 10kHz Threshold 4V | | | External power required |
| ACTIVE 12V DC | 4KΩ | | 10kHz Threshold 6V | | | External power required |
| ACTIVE 24V DC | 3KΩ | | 10kHz Threshold 12V | | | External power required |

Enclosures

Various types of enclosures can be selected, all ATEX, IECEx and CSA approved. The F012 is supplied in an GRP panel mount enclosure as standard, which can be converted to an IP67 / NEMA 4X GRP field mount enclosure by the addition of a back case. Most popular is our robust aluminum field mount enclosure which is also available with an extended backcover with undrilled preparation for direct meter mounting at the back side. It is so rugged, even a truck can stand on it! For the most challenging environments we have a durable high grade Stainless steel 316L enclosure. All enclosures have a IP67 / NEMA Type4X rating and EU or U.S. cable gland entry threads available.

Dimensions enclosures

Aluminum & GRP panel mount enclosure

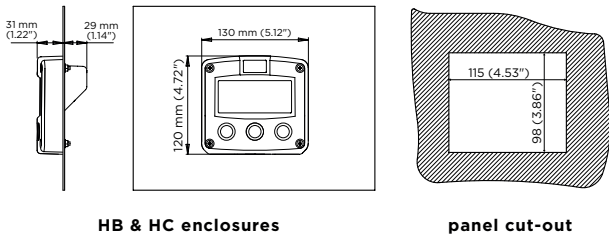

Aluminum, GRP & Stainless steel 316L field mount enclosures

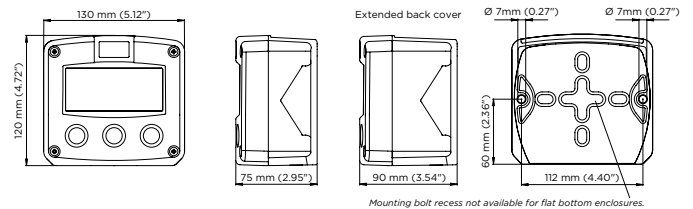

Cable entries

Aluminum / Stainless Steel

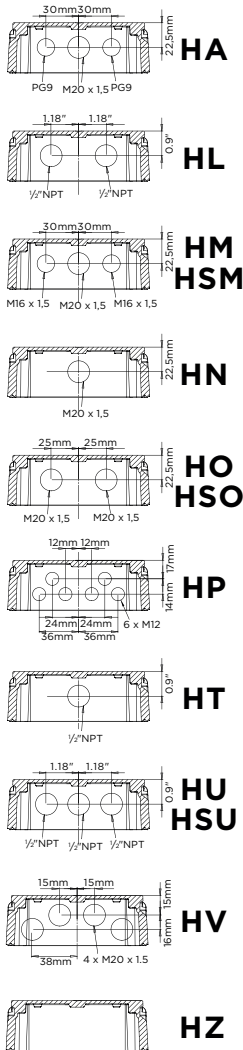

GRP

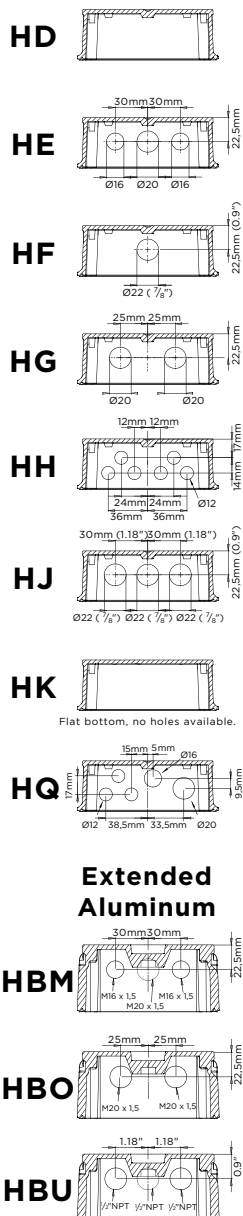

Terminal connections PB/PC - PD - PL - PX

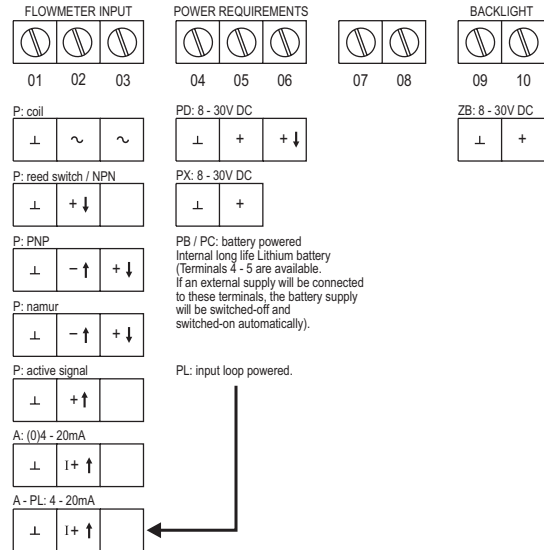

Terminal connections PF - PM

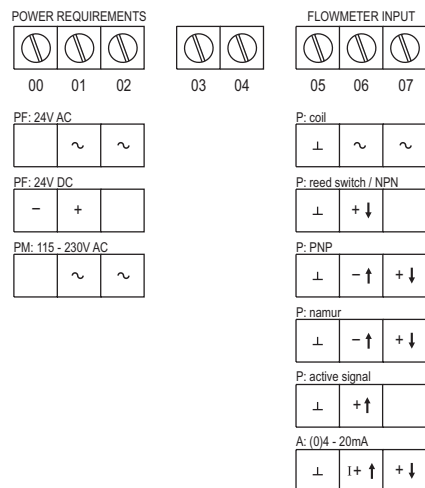

Configuration example F012-P-PB-(PX)-XX-(ZB)

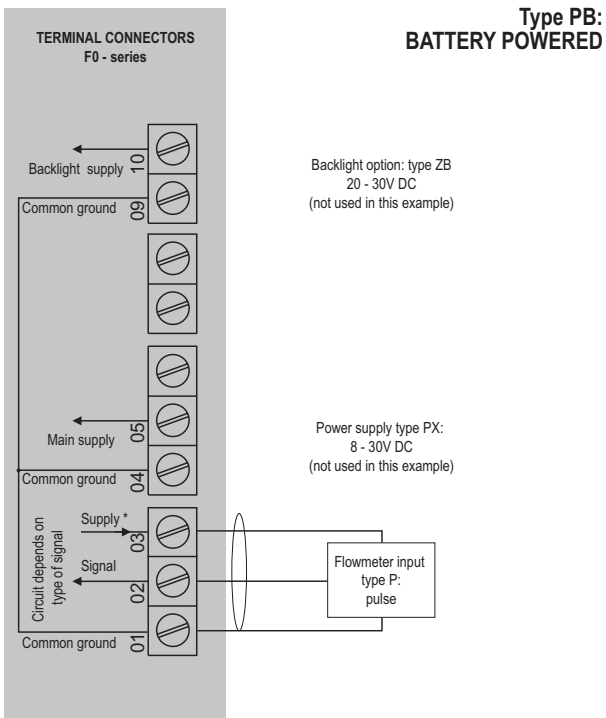

* Sensor supply voltage for pulse flowmeter type P:
Terminal 3: 1.2 / 3.2V DC.

* Sensor supply voltage for analog flowmeter type A:
Terminal 3: not available.

Configuration example F012-A-PL-XX-ZB

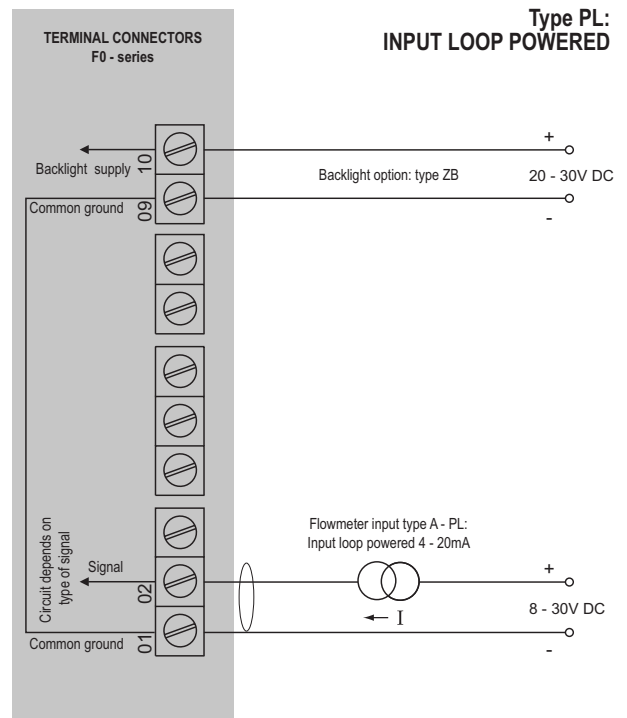

Configuration example F012-P-PD-XX-ZB

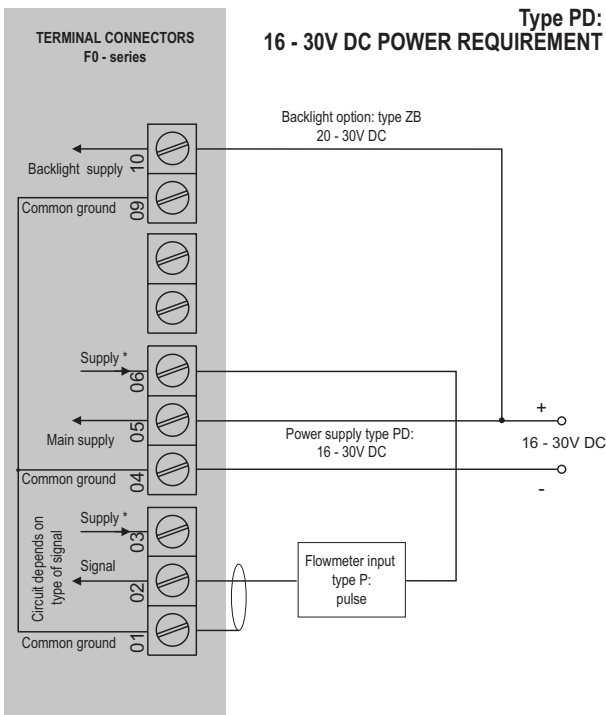

* Sensor supply voltage for pulse flowmeter type P:
Terminal 3: 1.2 / 3.2V DC. Terminal 6 with type PD: 8.2V DC.

* Sensor supply voltage for analog flowmeter type A:
Terminal 3: not available.
Terminal 6 with type PD: voltage as connected to terminal 5 (internally linked).

Configuration example F012-P-PM-XX-ZB

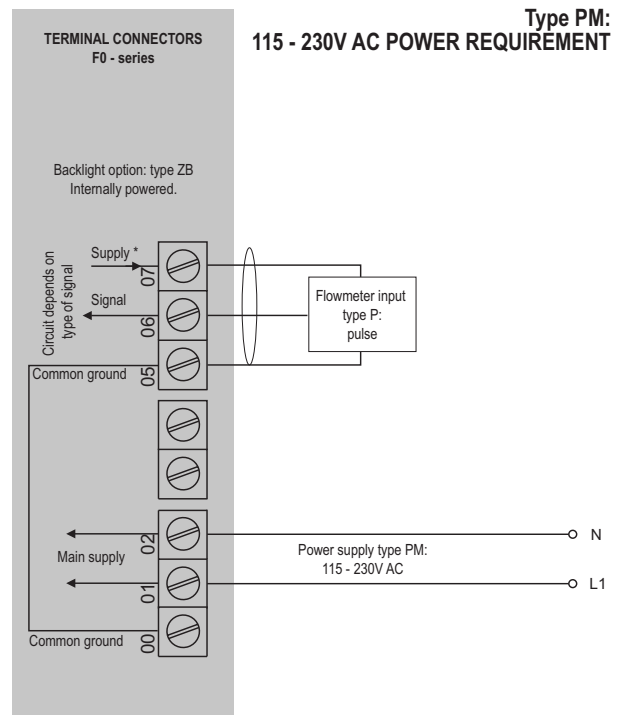

* Sensor supply voltage for pulse flowmeter type P:
Terminal 7: 1.2 / 3.2 / 8.2 / 12 / 24V DC.

* Sensor supply voltage for analog flowmeter type A:
Terminal 7: 8.2 / 12 / 24V DC.

Hazardous area applications

The F012-XI has been certified according to ATEX and IECEx by DEKRA and according to CSA c-us for use in Intrinsically Safe applications with an ambient temperature of -40°C to +70°C (-40°F to +158°F). For equipment category 1 D (EPL Da), -40°C to +50°C (-40°F to +122°F).

- The ATEX markings for gas and dust applications are:

Gas: **II 1 G Ex ia IIC T4 Ga.**

Dust: **II 1 D Ex ia IIIC T₂₀₀ 100 °C Da.**

- The IECEx markings for gas and dust applications are:

Gas: **Ex ia IIC T4 Ga**

Dust: **Ex ia IIIC T₂₀₀ 100 °C Da.**

- The CSA c-us markings are:

IS Class I/II/III, Division 1, Groups A to G T4.

Class 1 Zone 0 AEx ia IIC T4 Ga.

Ex ia IIC T4 Ga.

It is allowed to connect up to three I.S. power supplies to power the unit, sensor and backlight. Consult the certificate for the maximum input and output values of the circuits. The F012-PD-XI offers a 8.2V DC sensor supply to power e.g. a Namur sensor or the input voltage to power an analog sensor. An ATEX/IECEx approved flame proof Ex d enclosure is available as well. Please contact your supplier for further details.

Note: Extended aluminum enclosures are not available with CSA c-us approval.

Certificate of conformity KEMA 05ATEX1168 X • IECEx KEM 08.0006X

• [CSA.08.2059461](#)

Configuration example IIA - IIIB and IIC

F012-P-PC-(PX)-XI-(ZB) - Battery powered unit

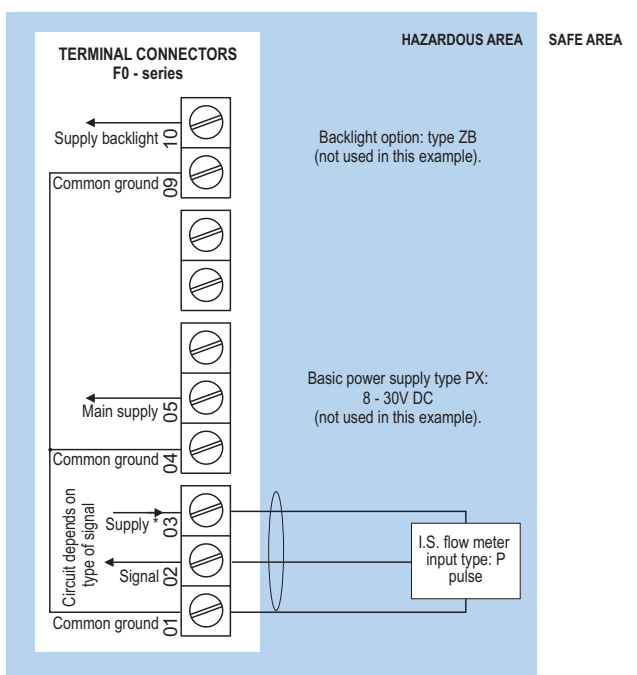

* Sensor supply voltage for pulse flowmeter type P : Terminal 3: 1.2 / 3.2V DC. Please note: type PX may be used in combination with the battery (type PC). PX will power the unit; the battery will be disabled automatically till power is disconnected.



Configuration example IIA - IIB and IIC - F012-P-PX-XI-(ZB) - Basic power requirement 8 - 30V DC

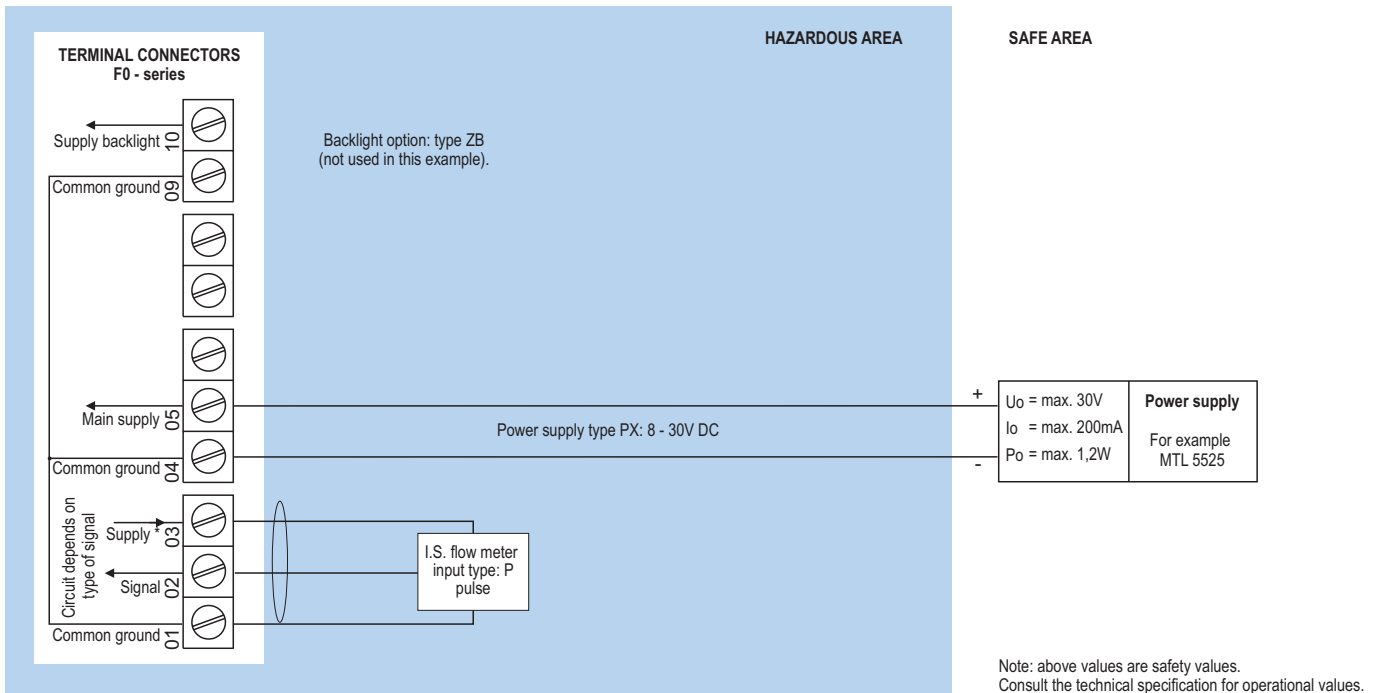

* Sensor supply voltage for pulse type P: Terminal 3: 1.2V / 3.2V DC.
Please note: type PX may be used in combination with the battery (type PC). PX will power the unit; the battery will be disabled automatically till power is disconnected.

Configuration example IIA - IIB and IIC - F012-P-PX-XI-ZB - Basic power requirement 8 - 30V DC

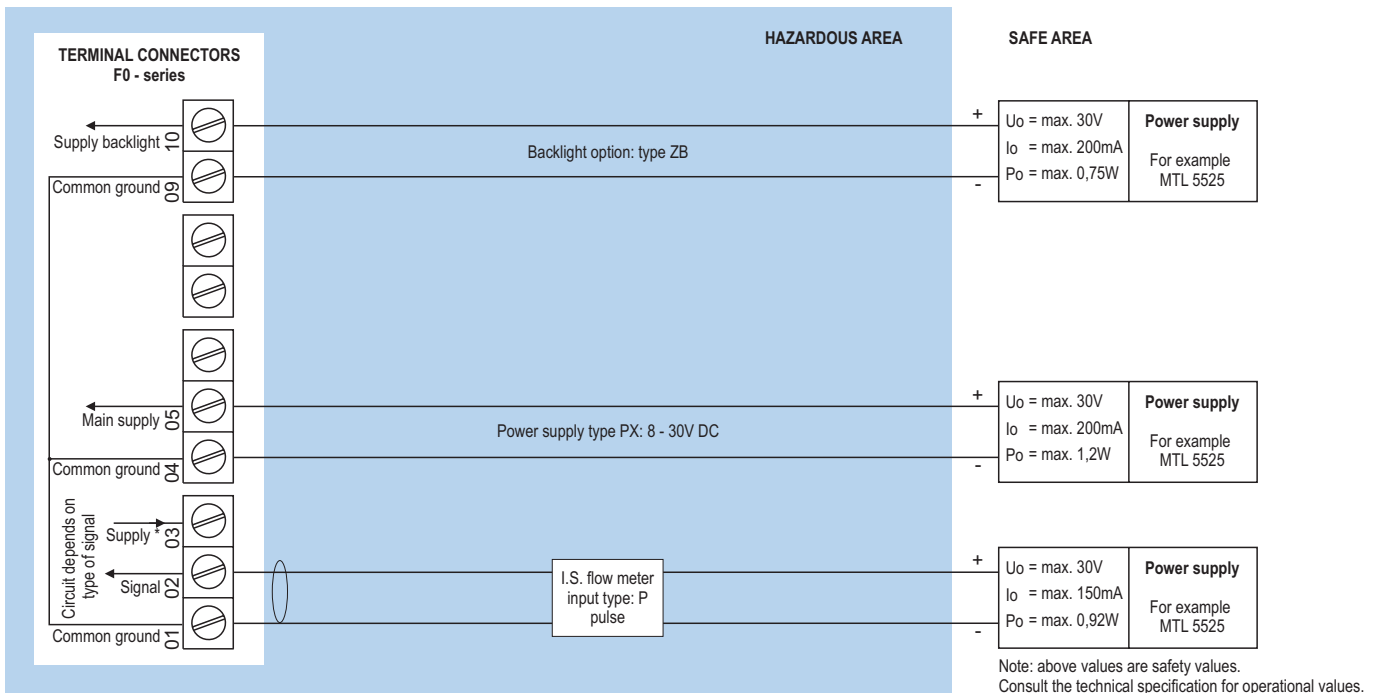

* Sensor supply voltage for pulse type P: Terminal 3: 1.2V / 3.2V DC.
Please note: type PX may be used in combination with the battery (type PC). PX will power the unit; the battery will be disabled automatically till power is disconnected.

Configuration example IIA - IIB and IIC - F012-P-PD-XI-ZB - Power requirement 16 - 30V DC

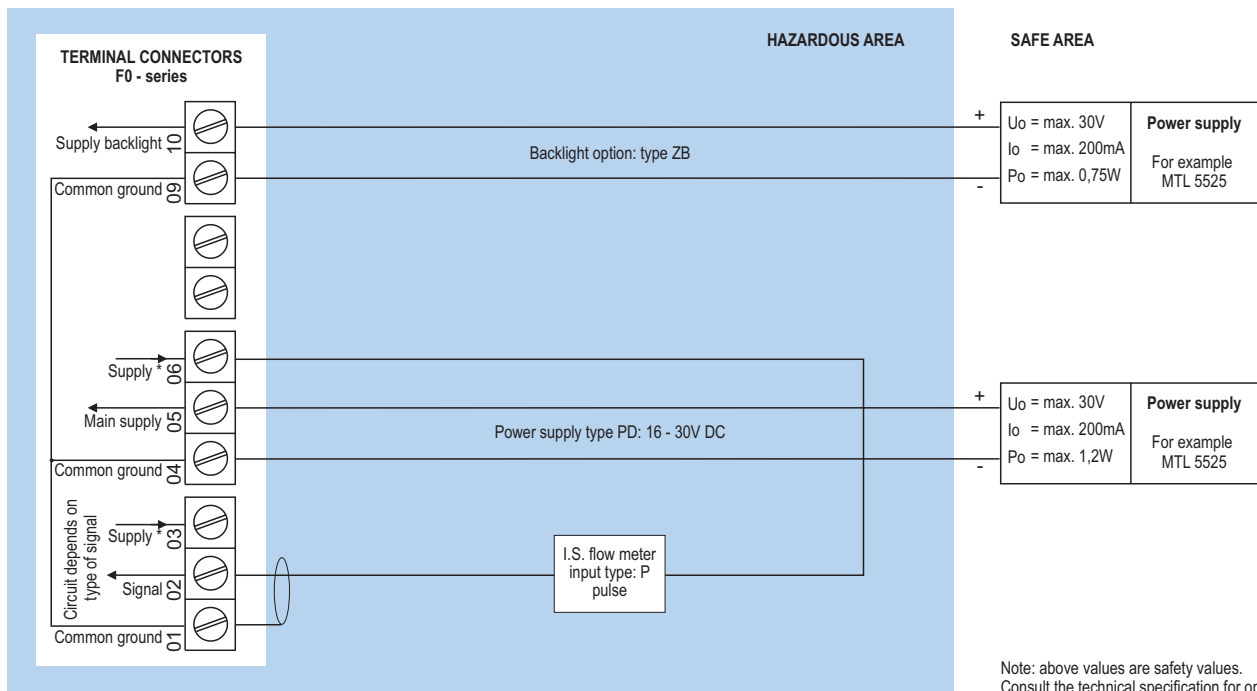

* Sensor supply voltage for pulse type P: Terminal 3: 1.2V / 3.2V DC, Terminal 6: 8.2V DC.
Please note: type PD may be used in combination with the battery (type PC). PD will power the unit; the battery will be disabled automatically till power is disconnected.

Configuration example IIA - IIB and IIC - F012-A-PD-XI-ZB - Power requirement 16 - 30V DC

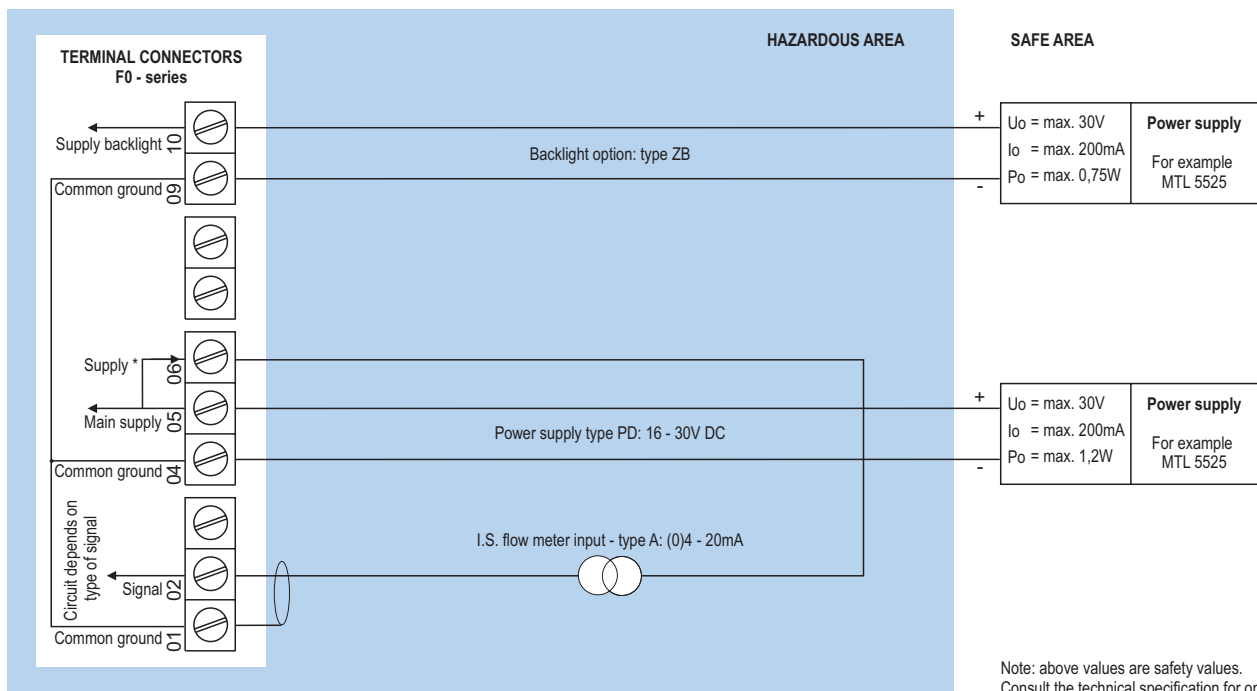

* Sensor supply voltage for analog flow meter type A: Terminal 6: as input voltage terminal 5 (internally linked).
Please note: type PD may be used in combination with the battery (type PC). PD will power the unit; the battery will be disabled automatically till power is disconnected.

Configuration example IIA - IIB and IIC - F012-A-PL-XI-ZB - Input loop powered

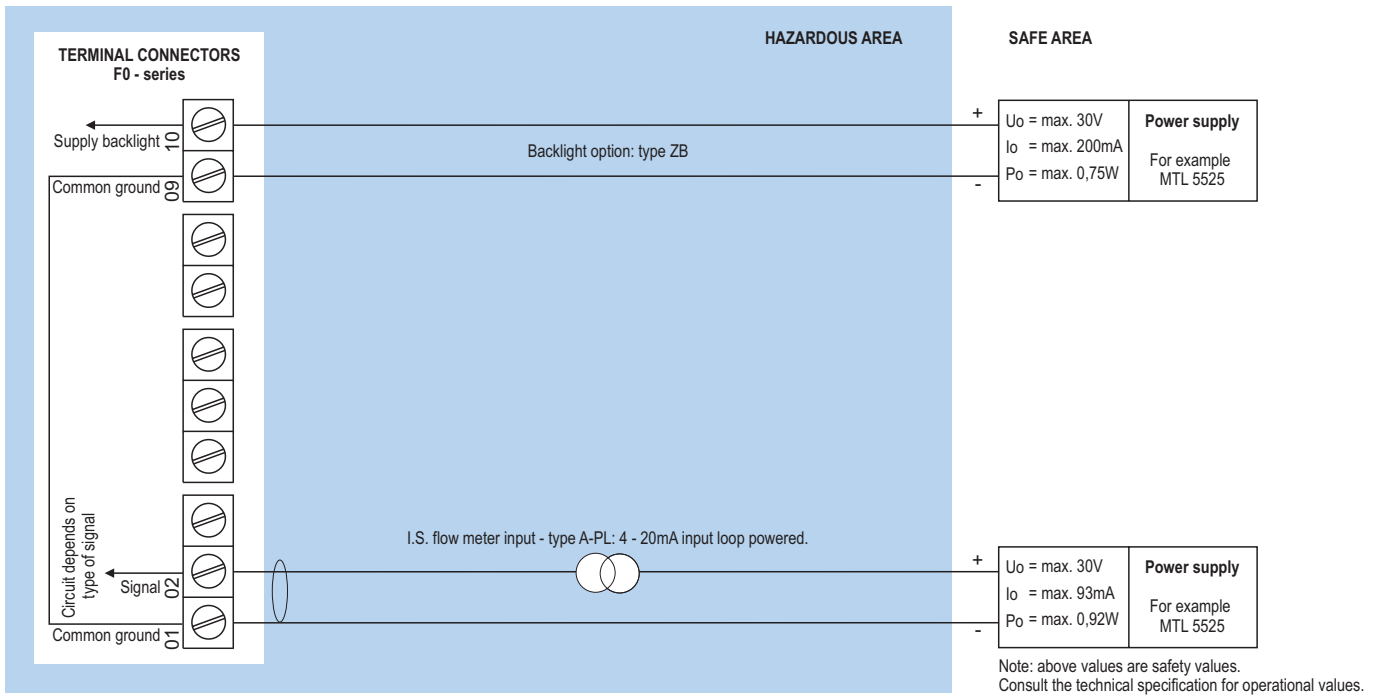

Sensor supply is not available: unit is input loop powered (type PL).
Please note: type PL may be used in combination with the battery (type PC). PL will power the unit; the battery will be disabled automatically till power is disconnected.

Configuration example IIA - IIB and IIC - F012-A-PX-XI-ZB - Basic power requirement 8 - 30V DC

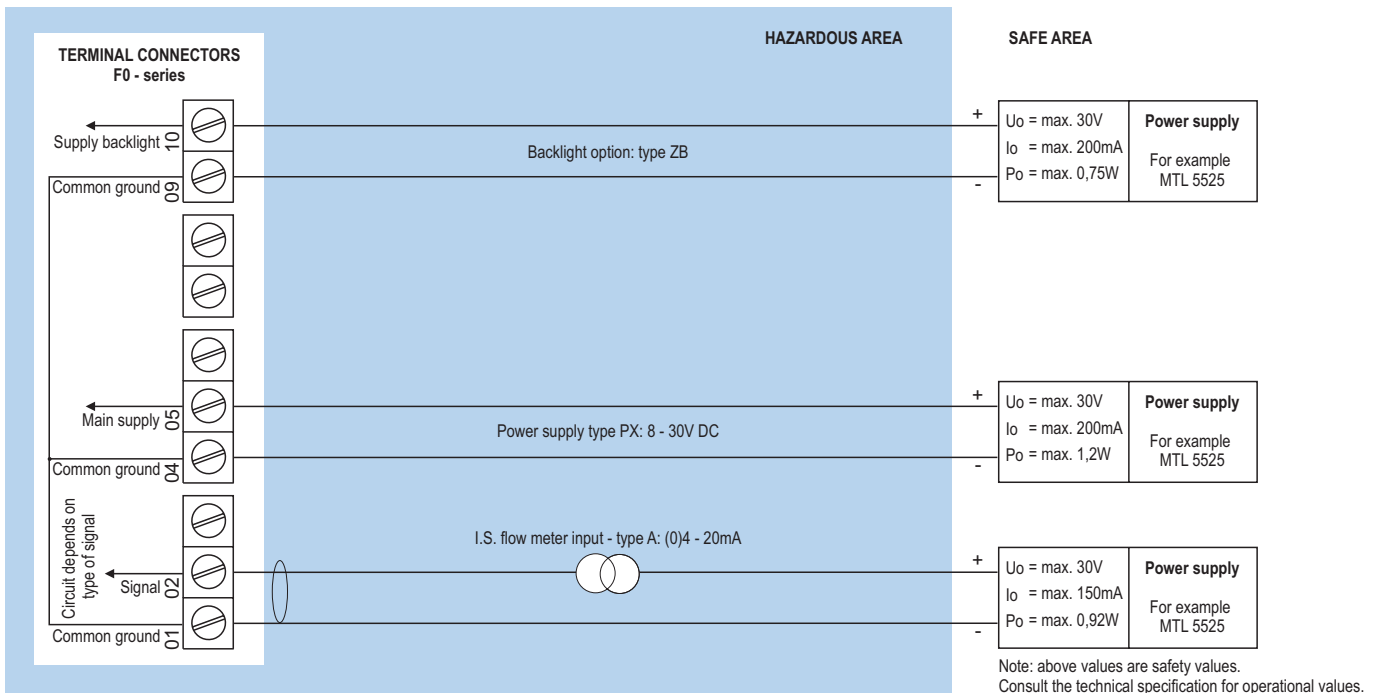

* Sensor supply voltage for analog flow meter type A: not available in this example.
Please note: type PX may be used in combination with the battery (type PC). PX will power the unit; the battery will be disabled automatically till power is disconnected.

Display

| | |
|---------------------|--|
| Type | High intensity reflective numeric and alphanumeric LCD, UV-resistant. |
| Dimensions | 90 x 40mm (3.5" x 1.6"). |
| Digits | Seven 17mm (0.67") and eleven 8mm (0.31") digits. Various symbols and measuring units. |
| Refresh rate | User definable: fast, 1sec, 3sec, 15sec, 30sec, off. |
| Option ZB | Transflective LCD with white LED-backlight. Intensity can be adjusted in the configuration menu. Good readings in full sunlight and darkness. Also available Intrinsically Safe. |

Ambient temperature

| | |
|--------------------|--|
| Safe areas | -40°C to +70°C (-40°F to +158°F). |
| EPL Ga / 1G | -40°C to +70°C (-40°F to +158°F). |
| EPL Da / 1D | -40°C to +50°C (-40°F to +122°F). max. dust layer thickness: 200mm. |
| EPL Db / 2D | -40°C to +70°C (-40°F to +158°F). max. dust layer thickness: 5mm. |

Power requirements

| | |
|----------------------|--|
| Type PB | Long life Lithium battery - life-time depends upon settings and configuration - up to 5 years. (requires PD, PL or PX) |
| Type PC | Intrinsically Safe long life lithium battery life-time depends upon settings and configuration - up to 5 years. (requires XI and PD, PL or PX) |
| Type PD | 16 - 30V DC. power consumption max. 1W. |
| Type PF | 24V AC / DC ± 10%. Power consumption max. 15W. |
| Type PL | Input loop powered from sensor signal 4 - 20mA (type "A"). |
| Type PM | 115 - 230V AC ± 10%. Power consumption max. 15W. |
| Type PX | 8 - 30V DC. Power consumption max. 0.3W. |
| Type ZB | 20 - 30V DC ± 10%. Power consumption max. 1W. With type PF / PM: internally powered. |
| Note PB/PF/PM | Not available Intrinsically Safe. |
| Note PF/PM | The total consumption of the sensor and backlight type ZB may not exceed 400mA @ 24V DC. |
| Note XI | For Intrinsically Safe applications, consult the safety values in the certificate. |

Sensor excitation

| | |
|----------------------|--|
| Type PB/PC/PX | 3.2V DC for pulse signals and 1.2V DC for coil pick-up. |
| Note PB/PC/PX | This is not a real sensor supply. Only suitable for sensors with a very low power consumption like coils (sine wave) and reed-switches. |
| Type PD | For pulse signals: 1.2 / 3.2 / 8.2V DC - max. 5mA@8.2V DC. For analog signals, the sensor supply voltage is according to the power supply voltage connected. |
| Type PF / PM | With pulse input: 1.2 / 3.2 / 8.2 / 12 / 24V DC - max. 400mA @ 24V DC. With analog input: 8.2 / 12 / 24V DC - max. 400mA @ 24V DC. |

Terminal connections

| | |
|-------------|--|
| Type | Removable plug-in terminal strip. Wire max. 1.5mm ² and 2.5mm ² |
|-------------|--|

Data protection

| | |
|-----------------|---|
| Type | EEPROM backup of all settings. Backup of running totals every minute. Data retention at least 10 years. |
| Password | Configuration settings can be password protected. |

Directives & Standards

| | |
|----------------------|---|
| EMC | EN 613 26-1, FCC 47 CFR Part 15 |
| Low voltage | EN/IEC 61010-1, CSA C22.2 No.61010-1, UL61010-1 |
| ATEX | EN IEC 60079-0, EN 60079-11 |
| IECEX | IEC 60079-0, IEC 60079-11 |
| CSA | CAN/CSA 22.2 No. 157, ANSI/UL 913 CAN/CSA 22.2 No. 142, UL 508 CAN/CSA 22.2 No. 60079-0, ANSI/ISA 60079-0 CAN/CSA 22.2 No. 60079-11, ANSI/ISA 60079-11 |
| RoHS | EN 50581, IEC 6300 |
| IP & NEMA | EN 60529, ANSI/IEC 60529, NEMA 250 |

Intrinsically Safe (Type XI)

| | |
|-----------------|---|
| ATEX | Gas: II 1 G Ex ia IIC T4 Ga. Dust: II 1 D Ex ia IIIC T ₂₀₀ 100 °C Da. |
| IECEX | Gas: Ex ia IIC T4 Ga. Dust: Ex ia IIIC T ₂₀₀ 100 °C Da. |
| CSA c-us | IS Class I/II/III, Division 1, Groups A to G T4. Class 1 Zone 0 AEx ia IIC T4 Ga. Ex ia IIC T4 Ga |
| Note | Extended aluminum enclosures are not available with CSAc-us approval. |
| CSA c-us | |

Explosion proof (Type XF)

| | |
|-------------------|---|
| ATEX/IECEX | Gas: II 2 G Ex db IIB+H2 T5 Gb. Dust: II 2 D Ex tb IIIC T80°C. |
| Protection | IP66 |
| Type XF | Dimensions of enclosure: 300 x 250 x 200mm (11.8" x 9.9" x 7.9") L x H x D. |
| Weight | Appr. 15kg. |

Enclosure

| | |
|---------------------|---|
| Window | Polycarbonate window. |
| Sealing | Silicone. |
| Control keys | Three industrial micro-switch keys. UV-resistant silicone keypad. |

Panel mount enclosures

| | |
|----------------------|---|
| Dimensions | 130 x 120 x 60mm (5.12" x 4.72" x 2.36") - W x H x D. |
| Panel cut-out | 115 x 98mm (4.53" x 3.86") L x H. |
| Type HB | Die-cast aluminum panel mount enclosure IP65 / NEMA Type4X. |
| Weight | 600 gr. |
| Type HC | GRP panel mount enclosure IP65 / NEMA Type4X, UV-resistant and flame retardant. |
| Weight | 450 gr. |
| Type HSB | Die-cast stainless steel 316L IP67/NEMA Type4X. |
| Weight | 1150gr. |

GRP wall / field mount enclosures

| | |
|-------------------|--|
| General | GRP wall/field mount enclosure IP67 / NEMA Type4X, UV-resistant and flame retardant. |
| Dimensions | 130 x 120 x 75mm (5.12" x 4.72" x 2.95") - W x H x D. |
| Weight | 600 gr. |
| Type HD | Cable entry: no holes. |
| Type HE | Cable entry: 2 x Ø 16mm and 1 x Ø 20mm. |
| Type HF | Cable entry: 1 x Ø 22mm (7/8"). |
| Type HG | Cable entry: 2 x Ø 20mm. |
| Type HH | Cable entry: 6 x Ø 12mm. |
| Type HJ | Cable entry: 3 x Ø 22mm (7/8"). |
| Type HK | Flat bottom, cable entry: no holes. |
| Type HQ | Cable entry: 1 x Ø 20mm, 1 x Ø 16mm & 3 x Ø 12mm. |

Aluminum wall / field mount enclosures

| | |
|--------------------|---|
| General | Die-cast aluminum wall/field mount enclosure IP67 / NEMA Type4X with 2-component UV-resistant coating. Extended back cover available with undrilled preparation for direct meter mounting. |
| Dimensions | 130 x 120 x 75mm (5.12" x 4.72" x 2.95") - W x H x D. 130 x 120 x 90mm (5.12" x 4.72" x 3.54") - W x H x D. |
| Weight | 1100 gr. / extended enclosure: 1310 gr. |
| Type HA | Cable entry: 2 x PG9 and 1 x M20. |
| Type HL | Cable entry: 2 x 1/2" NPT. |
| Type HM/HBM | Cable entry: 2 x M16 and 1 x M20. |
| Type HN | Cable entry: 1 x M20. |
| Type HO/HBO | Cable entry: 2 x M20. |
| Type HP | Cable entry: 6 x M12. |
| Type HT | Cable entry: 1 x 1/2" NPT. |
| Type HU/HBU | Cable entry: 3 x 1/2" NPT. |
| Type HV | Cable entry: 4 x M20. |
| Type HZ | Cable entry: no holes. |
| Note | Extended aluminum enclosures are not available with CSAC-us and FM approvals. |
| CSA c-us/FM | |

Stainless steel 316L wall / field mount enclosures

| | |
|-------------------|--|
| General | Die-cast stainless steel 316L wall / field mount enclosure with flat bottom. IP67 / NEMA Type4X. |
| Dimensions | 130 x 120 x 75mm (5.12" x 4.72" x 2.95") - W x H x D. |
| Weight | 2700 gr. |
| Type HSM | Cable entry: 2 x M16 + 1 x M20. |
| Type HSO | Cable entry: 2 x M20. |
| Type HSU | Cable entry: 3 x 1/2"NPT. |

Signal inputs - Flowmeter

| | |
|------------------------|---|
| Type P | Coil / sine wave (HI: 20mVpp or LO: 90mVpp - sensitivity selectable), NPN/PNP, open collector, reed switch, Namur, active pulse signals 8 - 12 and 24V DC. |
| Frequency | Minimum 0Hz - maximum 6kHz for total and flow rate. Maximum frequency depends on signal type and internal low-pass filter. E.g. reed switch with low-pass filter: max. frequency 120Hz. |
| K-Factor | 0.000010 - 9,999,999 with variable decimal position. |
| Low-pass filter | Available for all pulse signals. |
| Option ZF | coil sensitivity 10mVpp. |
| Option ZG | coil sensitivity 5mVpp. |
| Type A | (0)4 - 20mA. Analog input signal can be scaled to any desired range within 0 - 20mA. |
| Type U | 0 - 10V DC. Contact factory. |
| Accuracy | Resolution: 16 bit. Error < 0.01mA / ± 0.05% FS. Low level cut-off programmable. |
| Span | 0.0010 - 999,999 with variable decimal position. |
| Update time | Four times per second. |
| Voltage drop | Type A: max. 1V DC @ 20mA. |
| Voltage drop | Type A - PL (loop powered): max. 2.6V DC @ 20mA. |
| Relationship | Linear and square root calculation. |
| Note A | For signal type A: external power to sensor is required; e.g. type PD. |

Operator functions

| | |
|-----------------------|--|
| Displayed info | <ul style="list-style-type: none"> Flow rate and / or total. Total and accumulated total. Total can be reset to zero by pressing the CLEAR-key twice. |
|-----------------------|--|

Total

| | |
|-----------------|---|
| Digits | 7 digits. |
| Units | L, m ³ , GAL, USGAL, kg, lb, bbl, no unit. |
| Decimals | 0 - 1 - 2 or 3. |
| Note | Total can be reset to zero. |

Accumulated total

| | |
|-------------------------|-----------------------------------|
| Digits | 11 digits. |
| Units / Decimals | According to selection for total. |
| Note | Can not be reset to zero. |

Flow rate

| | |
|-------------------|--|
| Digits | 7 digits. |
| Units | mL, L, m ³ , Gallons, kg, Ton, lb, bl, cf, RND, ft ³ , scf, Nm ³ , NI, ical - no units. |
| Decimals | 0 - 1 - 2 or 3. |
| Time units | /sec - /min - /hr - /day. |

| | | Description |
|------------|-------------|---|
| Model | F012 | Flow rate indicator / totalizer displays flow rate and total simultaneously. |
| Input | A | (0)4 - 20mA input. |
| | P | Pulse input, e.g., coil, npn, pnp, namur, reed-switch. |
| Enclosures | HB | Aluminum panel mount enclosure. |
| | HC | GRP panel mount enclosure. |
| | HSB | Stainless steel 316L panel mount enclosure. |
| | HD | GRP field mount - Cable entry: no holes. |
| | HE | GRP field mount - Cable entry: 2 x Ø 16mm & 1 x Ø 20mm. |
| | HF | GRP field mount - Cable entry: 1 x Ø 22mm (7/8"). |
| | HG | GRP field mount - Cable entry: 2 x Ø 20mm. |
| | HH | GRP field mount - Cable entry: 6 x Ø 12mm. |
| | HJ | GRP field mount - Cable entry: 3 x Ø 22mm (7/8"). |
| | HK | GRP field mount, flat bottom - Cable entry: no holes. |
| | HQ | GRP field mount - Cable entry: 1 x Ø 20mm, 1 x Ø 16mm & 3 x Ø 12mm. |
| | HA | Aluminum field mount - Cable entry: 2 x PG9 + 1 x M20. |
| | HL | Aluminum field mount - Cable entry: 2 x 1/2"NPT. |
| | HM | Aluminum field mount - Cable entry: 2 x M16 + 1 x M20. |
| | HN | Aluminum field mount - Cable entry: 1 x M20. |
| | HO | Aluminum field mount - Cable entry: 2 x M20. |
| | HP | Aluminum field mount - Cable entry: 6 x M12. |
| | HT | Aluminum field mount - Cable entry: 1 x 1/2"NPT. |
| | HU | Aluminum field mount - Cable entry: 3 x 1/2"NPT. |
| | HV | Aluminum field mount - Cable entry: 4 x M20. |
| | HZ | Aluminum field mount - Cable entry: no holes. |
| | HBM | Extended Alu. field/meter mount - Cable entry: 2 x M16 + 1 x M20 (not with CSAc-us approval). |
| | HBO | Extended Alu. field/meter mount - Cable entry: 2 x M20 (not with CSAc-us approval). |
| | HBU | Extended Alu. field/meter mount - Cable entry: 3 x 1/2"NPT (not with CSAc-us approval). |
| | HSM | Stainless steel 316L field mount - Cable entry: 2 x M16 + 1 x M20. |
| | HSO | Stainless steel 316L field mount - Cable entry: 2 x M20. |
| | HSU | Stainless steel 316L field mount - Cable entry: 3 x 1/2"NPT. |
| | Power | PD |
| PF | | 24V AC/DC + sensor supply - requires XX. |
| PL | | Input loop powered from sensor signal type "A". |
| PM | | 115 - 230V AC + sensor supply - requires XX. |
| PX | | Basic power supply 8 - 30V DC. |
| Battery | PB | Additional lithium battery powered (opt.) - requires XX and PD, PL or PX. |
| | PC | Additional lithium battery powered (opt.) - Intrins. safe - requires XI and PD, PL or PX. |
| Hazardous | XI | Intrinsically safe, according ATEX, IECEx and CSA c-us. |
| | XF | Ex d enclosure - 3 keys according ATEX and IECEx. |
| | XX | Safe area only, according CE / UKCA. |
| Options | ZB | Backlight. |
| | ZF | Coil input 10mVpp. |
| | ZG | Coil input 5mVpp. |
| | ZX | No options. |

The **bold** marked text contains the standard configuration: F012-P-HC-PX-XX-ZX.