

Your success counts

## Flow rate Indicator / Totalizer with pulse signal output



The F-Series is your first and safest choice for field mount indicators in safe and hazardous area applications. Especially in harsh weather conditions like rain, snow, salty atmospheres and temperatures between  $-40^{\circ}\text{C}$  up to  $+70^{\circ}\text{C}$  ( $-40^{\circ}\text{F}$  up to  $158^{\circ}\text{F}$ ).

### Advantages

- Robust aluminum or stainless steel 316L field enclosure (IP67 / NEMA Type4X). It is so rugged, a truck can even stand on it!
- Intrinsically Safe available - ATEX, IECEx and CSA approval for gas and dust applications.
- Programming can be done by your own crew, with the sensible menu-driven structure, saving cost and irritation. Know one, know them all!
- Very diverse mounting possibilities: walls, pipes, panels or directly onto outdoor sensors!

### Features

- Displays instantaneous flow rate, total and accumulated total.
- Large 17mm (0.67") digits for flow rate or total.
- Easy configuration with clear alphanumerical display.
- LED backlight option.
- Selectable on-screen engineering units for volumetric or mass.
- Ability to process all types of signals: Sine wave (coil), NAMUR, NPN/PNP pulse, Reed-switch, Active pulse signals, (0)4-20mA.
- Scaled pulse signal output according to accumulated total.
- Power requirements: Input loop powered, battery powered or 8 - 30V DC, 24V AC/DC and 115 - 230V AC.
- Sensor supply: 3.2 / 8.2 / 12 / 24V DC.
- Auto backup of settings and running totals.
- Explosion/flame proof available, according ATEX/IECEx.

## Introduction

The F014 is a local indicator to display the actual flow rate, total and accumulated total. The total can be reset to zero by pressing the CLEAR button twice. The eleven digit accumulated total however can not be reset to zero. Related to the accumulated total, a scaled pulse is generated for re-transmitting the count on the display. A wide selection of options further enhances the capabilities of this model.

## Display

The display has large 17mm segments which can be set to show total or flow rate. On-screen engineering units are easily configured from a comprehensive menu, whilst different units for flow rate and total can be displayed simultaneously. The accumulated total can register up to 11 digits and is backed-up in EEPROM memory where it is regularly updated.

## Configuration

All configuration settings are accessed via a simple operator menu which can be password protected. Each setting is clearly indicated with an alphanumerical description, which avoids confusing abbreviations. Once familiar with one F-series product, you will be able to program all models in the series without a manual. All settings are safely stored in EEPROM memory in the event of sudden power failure.

## Hazardous area

For hazardous area applications, this model is ATEX, IECEx and CSA certified as Intrinsically Safe for gas and dust applications, with an allowed ambient temperature of -40°C to +70°C (-40°F to +158°F). A flame proof Ex d enclosure with ATEX/IECEx certification is also available.



## Backlight

For those applications where readability during day and night is an issue, a white backlight is available. The intensity can be adjusted from the keyboard. The display is a transfective type, which means that a high contrast reading is guaranteed in full sunlight as well as during the night. This backlight option is also available Intrinsically Safe.

## Pulse output

The scaleable pulse output reflects the count on the accumulated display. The pulse width is user defined from 0.001 second up to 10 seconds. The maximum output frequency is 500Hz. The output signal can be a passive NPN, active PNP or an isolated electro-mechanical relay.

## Power requirements

Several power supply options are available to power the F014 and sensor. Most popular is our battery powered version with a long life lithium battery which will last up to five years. For analog sensors, a 4 - 20mA loop powered version is available as well. A real sensor supply is offered with the 24V AC/DC or 115 - 230V AC power requirement option.



All info at a glance



Easy to install



Easy to program



Know one know them all!



Reliable



User-friendly

### Overview application F014

The F-Series is your first and safest choice for field mount indicators in safe and hazardous area applications. Especially in harsh weather conditions like rain, snow, salty atmospheres and temperatures between -40°C up to +70°C (-40°F up to 158°F). Flow measurement where re-transmission of the totalizer function is required. Alternative basic models: F010 - F011 - F012 - F013 or more advanced F016, F110 and higher or the D-Series DIN panel mount flow rate indicators.



### Signal input

The F014 accepts most pulse and analog input signals for volumetric flow or mass flow measurement. The input signal type can be selected by the user in the configuration menu without having to adjust any sensitive mechanical dip-switches, jumpers or trimmers. The analog input is available with linear and square root calculation and even as 4 - 20mA input loop powered.

Type of signal	Resistance	Low Pass filter (LP)	Max. frequency	Max. frequency Low Pass filter (LP)	Min. amplitude p-p	Remark
NPN	100kΩ pull-up	100kΩ pull-up	6kHz Threshold 1.2V	1.2kHz		Open collector
REED	1MΩ pull-up	1MΩ pull-up	600Hz Threshold 1.2V	120Hz		
PNP	47KΩ pull-down	100KΩ pull-down	6kHz Threshold 1.2V	1.2kHz		
NAMUR	820Ω pull-down	-	4kHz	-		External power required
COIL LO	-	-		-	90mV <sub>pp</sub>	Default sensitivity
COIL-HI					20mV <sub>pp</sub>	Sensitive for interference!
COIL-HI (Type ZF)	-	-	-	-	10mV <sub>pp</sub>	
COIL-HI (Type ZG)					5mV <sub>pp</sub>	
ACTIVE 8.2V DC	3K9Ω		10kHz Threshold 4V			External power required
ACTIVE 12V DC	4KΩ		10kHz Threshold 6V			External power required
ACTIVE 24V DC	3KΩ		10kHz Threshold 12V			External power required

## Enclosures

Various types of enclosures can be selected, all ATEX, IECEx and CSA approved. The F014 is supplied in an GRP panel mount enclosure as standard, which can be converted to an IP67 / NEMA 4X GRP field mount enclosure by the addition of a back case. Most popular is our robust aluminum field mount enclosure which is also available with an extended backcover with undrilled preparation for direct meter mounting at the back side. It is so rugged, even a truck can stand on it! For the most challenging environments we have a durable high grade Stainless steel 316L enclosure. All enclosures have a IP67 / NEMA Type4X rating and EU or U.S. cable gland entry threads available.

## Dimensions enclosures

Aluminum & GRP panel mount enclosure

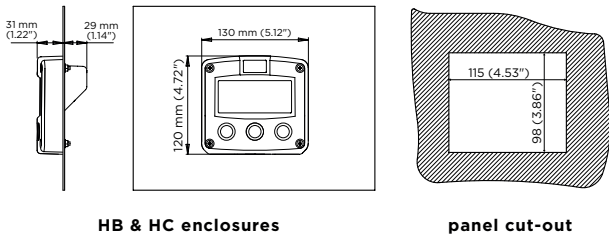

Aluminum, GRP & Stainless steel 316L field mount enclosures

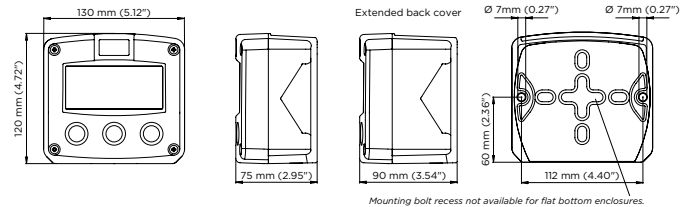

Cable entries

### Aluminum / Stainless Steel

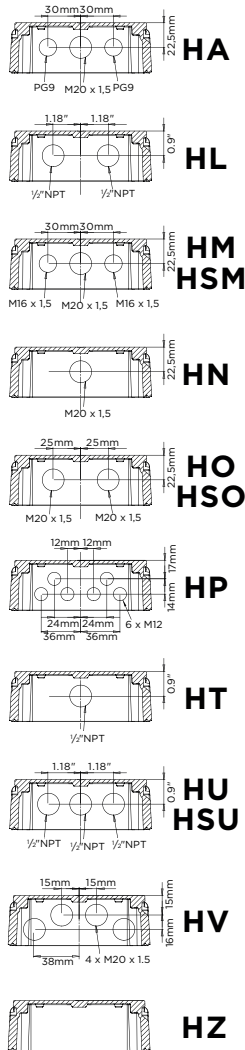

### GRP

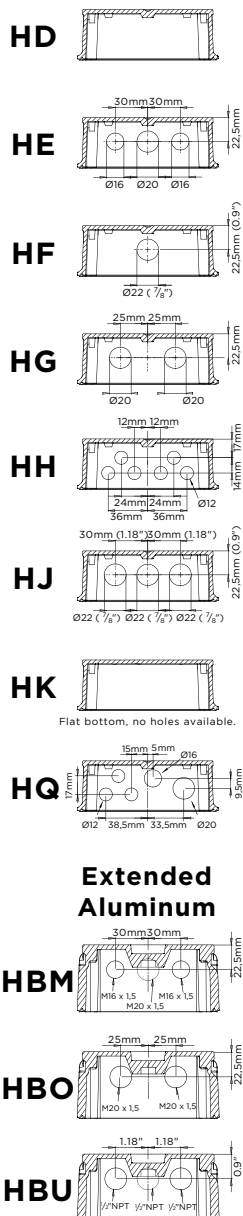

## Terminal connections PB/PC - PD - PL - PX

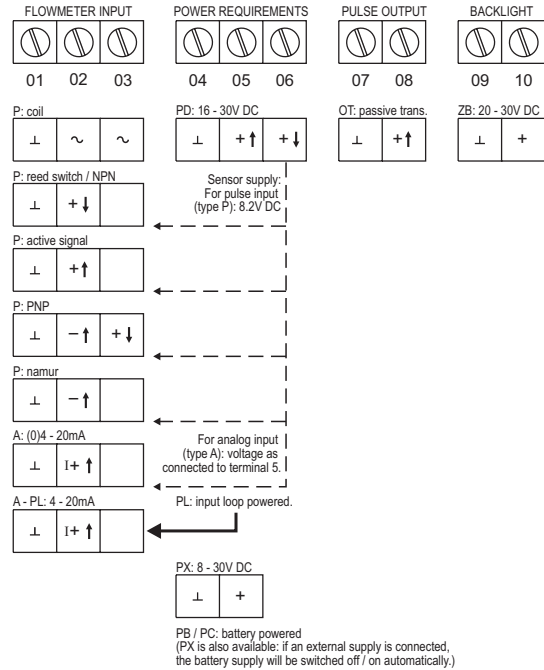

## Terminal connections PF - PM

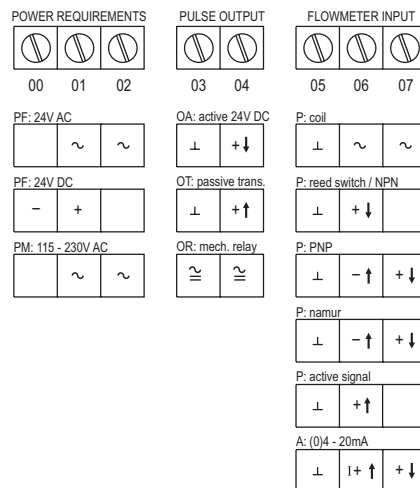

Configuration example F014-P-OT-PB-(PX)-XX-(ZB)

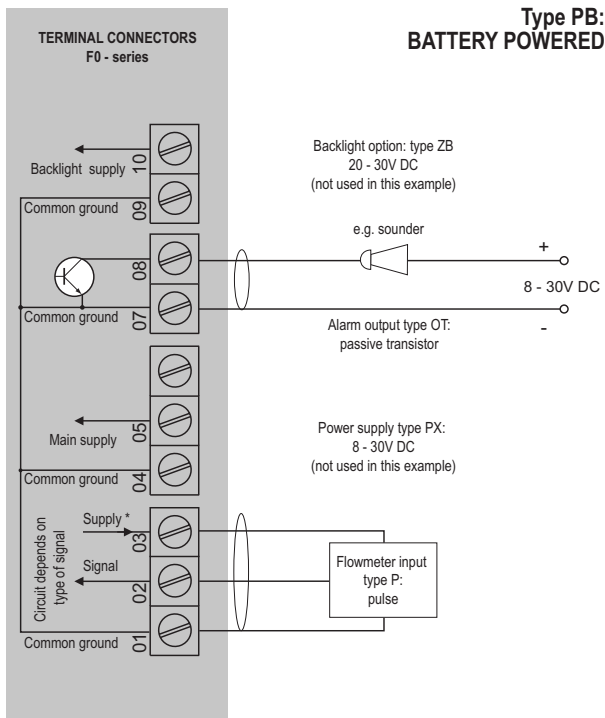

\* Sensor supply voltage for pulse flowmeter type P:  
Terminal 3: 1.2 / 3.2V DC.

\* Sensor supply voltage for analog flowmeter type A:  
Terminal 3: not available.

Configuration example F014-A-(OT)-PL-XX-ZB

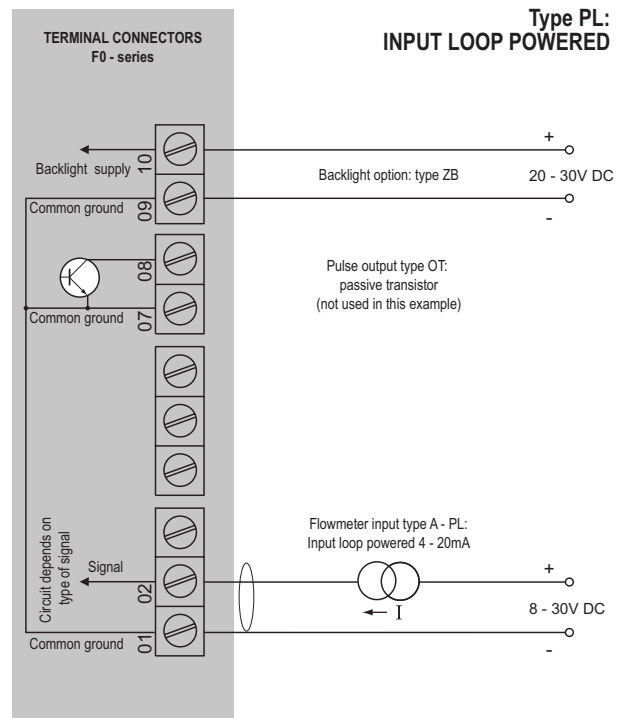

Sensor supply: sensor is externally powered.

Configuration example F014-P-OA-PF-XX-ZB

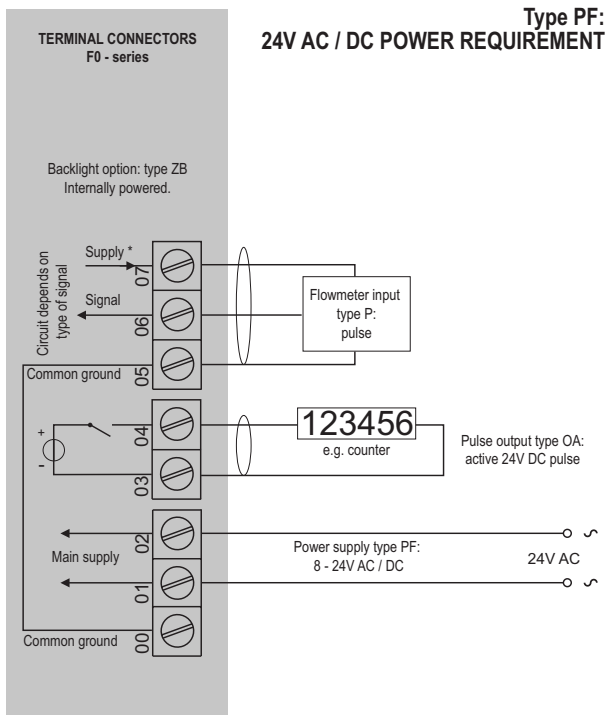

\* Sensor supply voltage for pulse flowmeter type P:  
Terminal 7: 1.2 / 3.2 / 8.2 / 12 / 24V DC.

\* Sensor supply voltage for analog flowmeter type A:  
Terminal 7: 8.2 / 12 / 24V DC.

Configuration example F014-P-OR-PM-XX-ZB

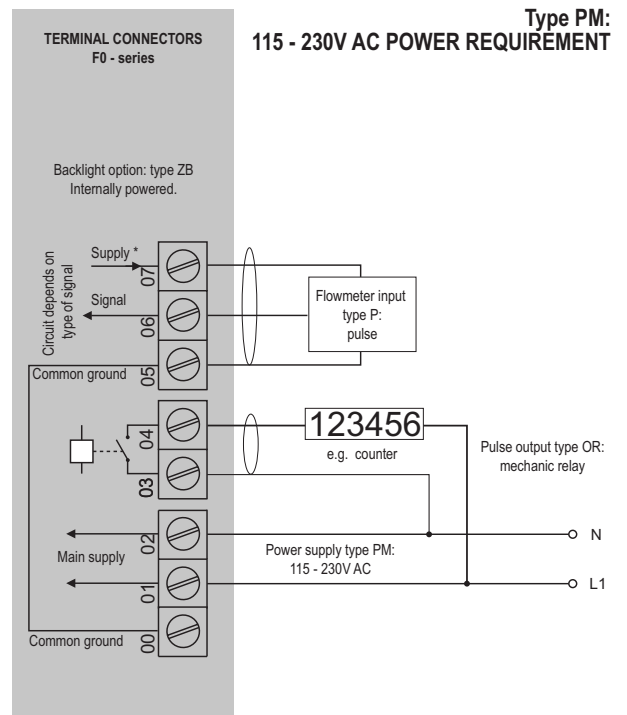

\* Sensor supply voltage for pulse flowmeter type P:  
Terminal 7: 1.2 / 3.2 / 8.2 / 12 / 24V DC.

\* Sensor supply voltage for analog flowmeter type A:  
Terminal 7: 8.2 / 12 / 24V DC.

## Hazardous area applications

The F014-XI has been certified according to ATEX and IECEx by DEKRA and according to CSA c-us for use in Intrinsically Safe applications with an ambient temperature of -40°C to +70°C (-40°F to +158°F). For equipment category 1 D (EPL Da), -40°C to +50°C (-40°F to +122°F).

- The ATEX markings for gas and dust applications are:

Gas: **II 1 G Ex ia IIC T4 Ga.**

Dust: **II 1 D Ex ia IIIC T<sub>200</sub> 100 °C Da.**

- The IECEx markings for gas and dust applications are:

Gas: **Ex ia IIC T4 Ga**

Dust: **Ex ia IIIC T<sub>200</sub> 100 °C Da.**

- The CSA c-us markings are:

**IS Class I/II/III, Division 1, Groups A to G T4.**

**Class 1 Zone 0 AEx ia IIC T4 Ga.**

**Ex ia IIC T4 Ga.**

It is allowed to connect up to three I.S. power supplies to power the unit, sensor and backlight. Consult the certificate for the maximum input and output values of the circuits. The F014-PD-XI offers a 8.2V DC sensor supply to power e.g. a Namur sensor or the input voltage to power an analog sensor. An ATEX/IECEx approved flame proof Ex d enclosure is available as well. Please contact your supplier for further details.

Note: Extended aluminum enclosures are not available with CSA c-us approval.

*Certificate of conformity KEMA 05ATEX1168 X • IECEx KEM 08.0006X*

- CSA.08.2059461*



*Configuration example IIA - IIIB and IIC*

*F014-P-(OT)-PC-(PX)-XI-(ZB) - Battery powered unit*

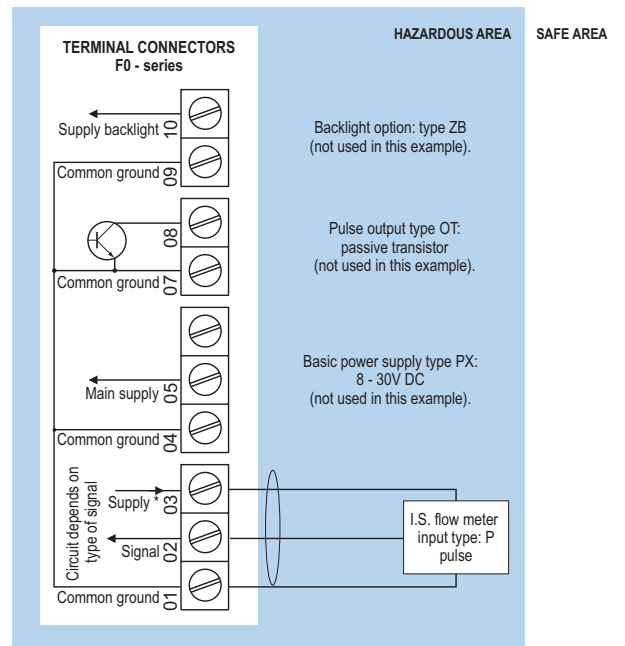

\* Sensor supply voltage for pulse flow meter type P: Terminal 3: 1.2 / 3.2V DC. Please note: type PX may be used in combination with the battery (type PC). PX will power the unit; the battery will be disabled automatically till power is disconnected.

## Configuration example IIA - IIB and IIC - F014-P-OT-PX-XI-(ZB) - Basic power requirement 8 - 30V DC

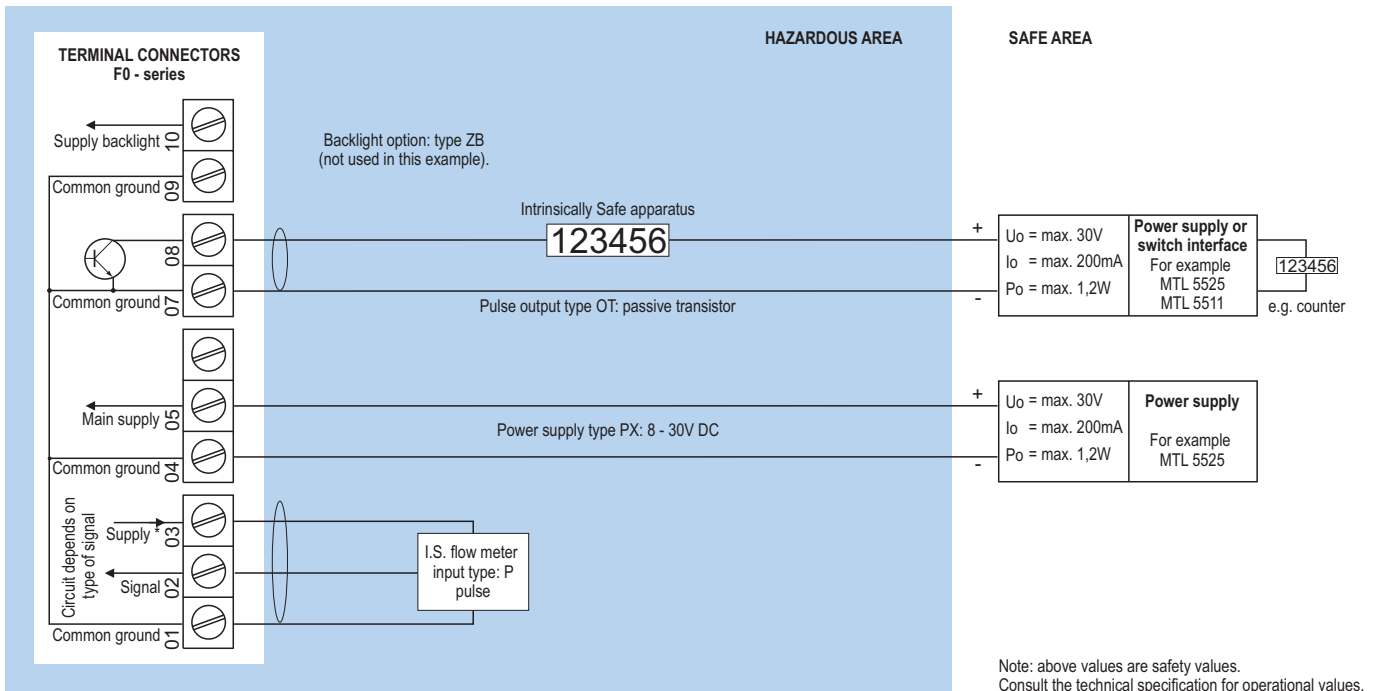

\* Sensor supply voltage for pulse type P: Terminal 3: 1.2V / 3.2V DC.  
Please note: type PX may be used in combination with the battery (type PC). PX will power the unit; the battery will be disabled automatically till power is disconnected.

## Configuration example IIA - IIB and IIC - F014-P-OT-PX-XI-ZB - Basic power requirement 8 - 30V DC

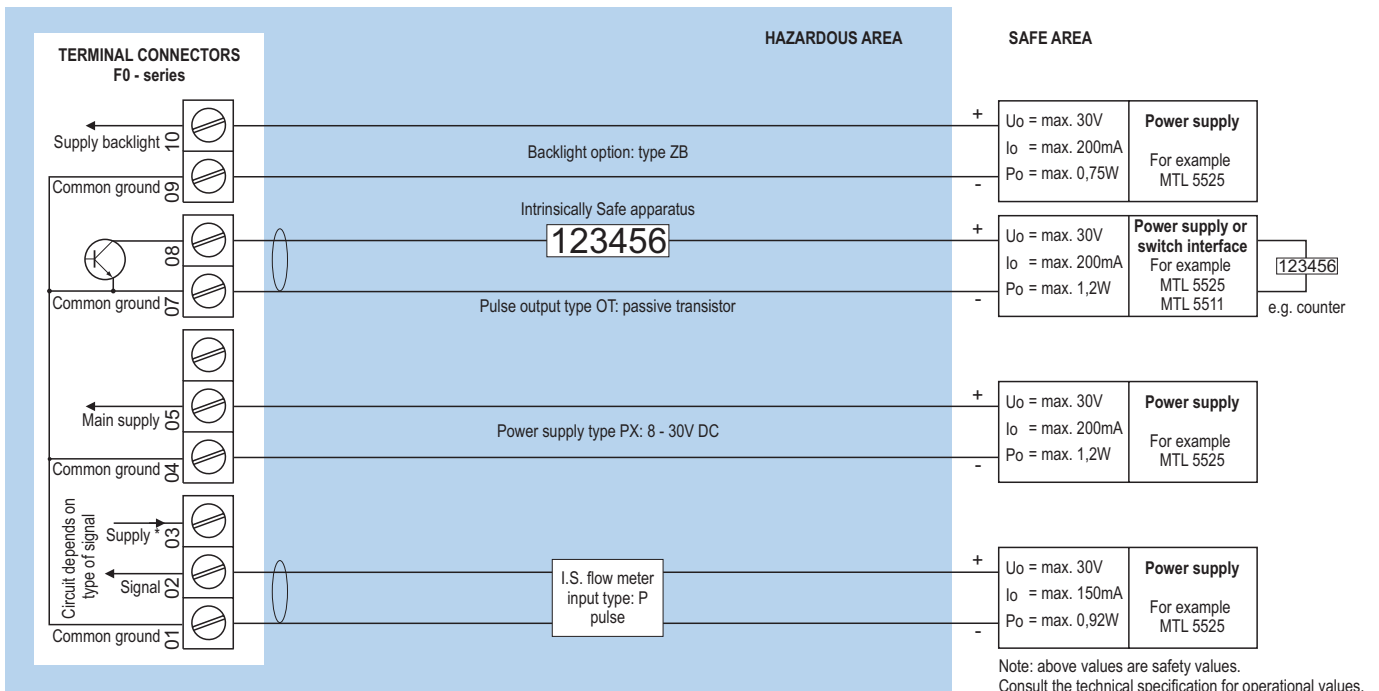

\* Sensor supply voltage for pulse type P: Terminal 3: 1.2V / 3.2V DC.  
Please note: type PX may be used in combination with the battery (type PC). PX will power the unit; the battery will be disabled automatically till power is disconnected.

## Configuration example IIA - IIB and IIC - F014-P-OT-PD-XI-ZB - Power requirement 16 - 30V DC

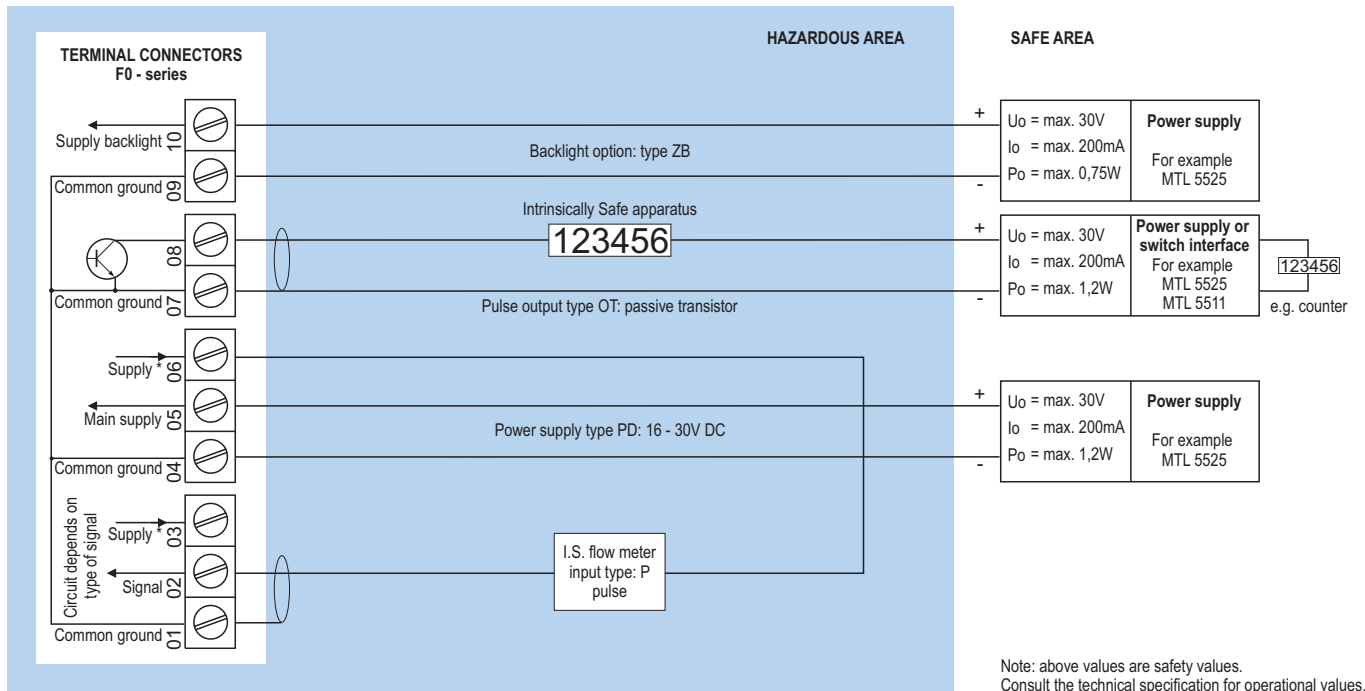

\* Sensor supply voltage for pulse type P: Terminal 3: 1.2V / 3.2V DC, Terminal 6: 8.2V DC.  
Please note: type PD may be used in combination with the battery (type PC). PD will power the unit; the battery will be disabled automatically till power is disconnected.

## Configuration example IIA - IIB and IIC - F014-A-OT-PD-XI-ZB - Power requirement 16 - 30V DC

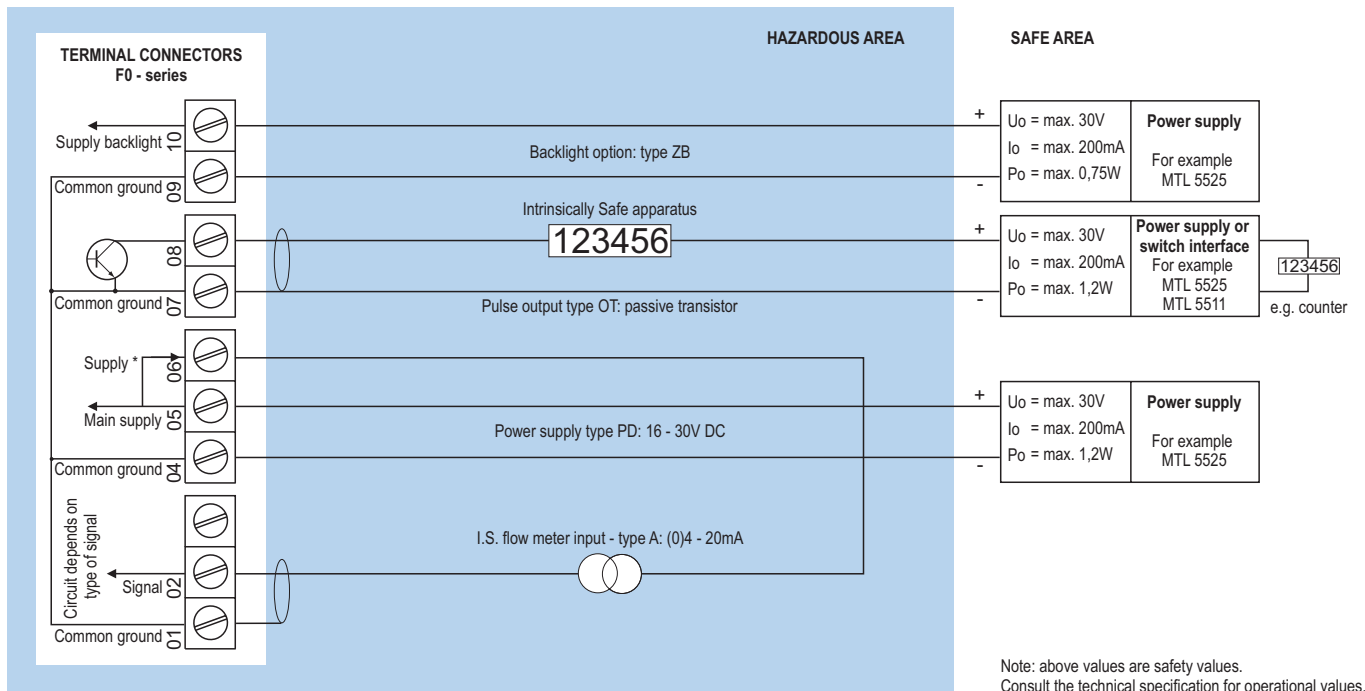

\* Sensor supply voltage for analog flow meter type A: Terminal 6: as input voltage terminal 5 (internally linked).  
Please note: type PD may be used in combination with the battery (type PC). PD will power the unit; the battery will be disabled automatically till power is disconnected.

Configuration example IIA - IIB and IIC - F014-A-OT-PL-XI-ZB - Input loop powered

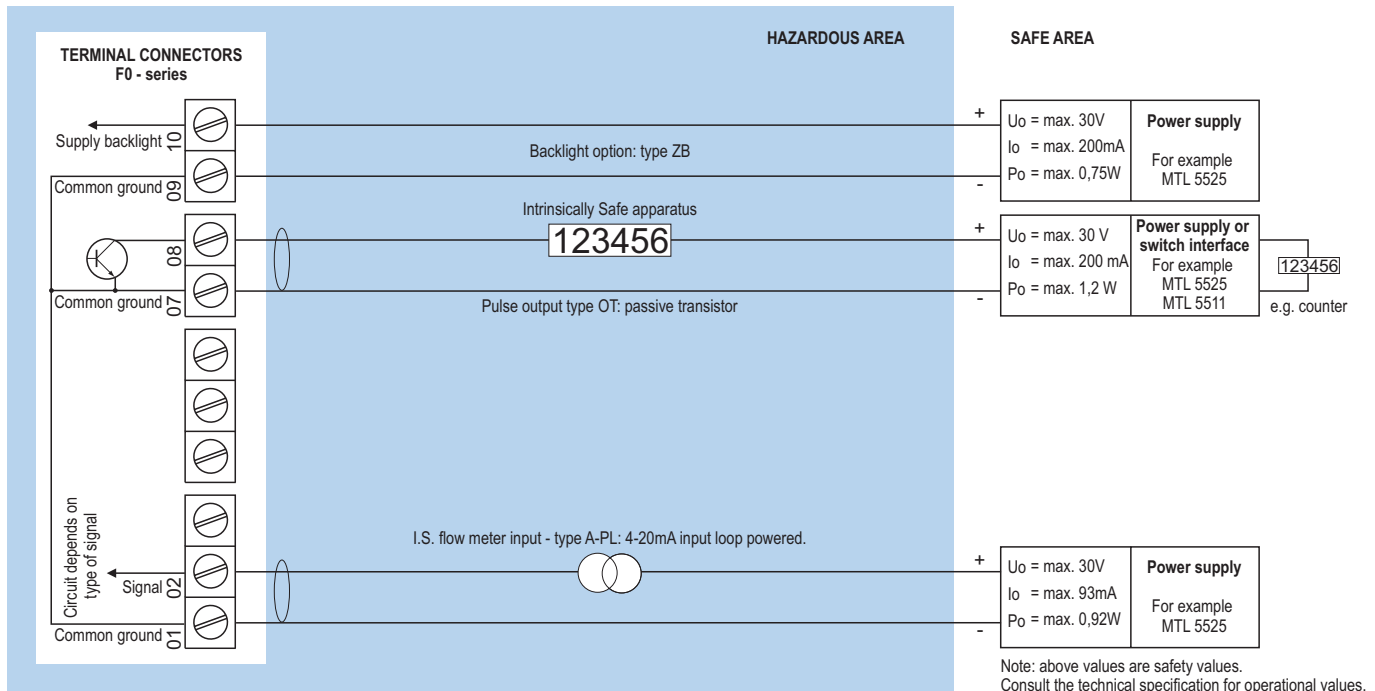

Sensor supply is not available: unit is input loop powered (type PL).  
Please note: type PL may be used in combination with the battery (type PC). PL will power the unit; the battery will be disabled automatically till power is disconnected.

Configuration example IIA - IIB and IIC - F014-A-OT-PX-XI-ZB - Basic power requirement 8 - 30V DC

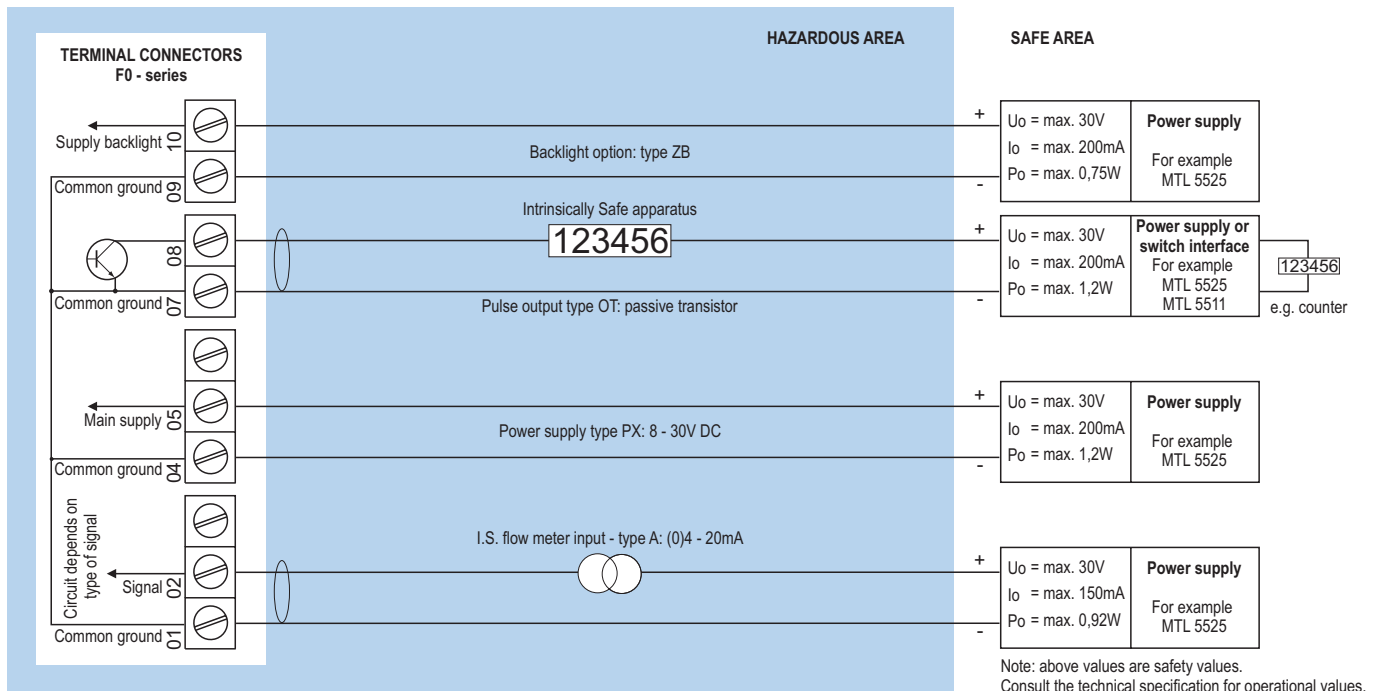

\* Sensor supply voltage for analog flow meter type A: not available in this example.  
Please note: type PX may be used in combination with the battery (type PC). PX will power the unit; the battery will be disabled automatically till power is disconnected.

## Display

<b>Type</b>	High intensity reflective numeric and alphanumeric LCD, UV-resistant.
<b>Dimensions</b>	90 x 40mm (3.5" x 1.6").
<b>Digits</b>	Seven 17mm (0.67") and eleven 8mm (0.31") digits. Various symbols and measuring units.
<b>Refresh rate</b>	User definable: fast, 1sec, 3sec, 15sec, 30sec, off.
<b>Option ZB</b>	Transflective LCD with white LED-backlight. Intensity can be adjusted in the configuration menu. Good readings in full sunlight and darkness. Also available Intrinsically Safe.

## Ambient temperature

<b>Safe areas</b>	-40°C to +70°C (-40°F to +158°F).
<b>EPL Ga / 1G</b>	-40°C to +70°C (-40°F to +158°F).
<b>EPL Da / 1D</b>	-40°C to +50°C (-40°F to +122°F). max. dust layer thickness: 200mm.
<b>EPL Db / 2D</b>	-40°C to +70°C (-40°F to +158°F). max. dust layer thickness: 5mm.

## Power requirements

<b>Type PB</b>	Long life Lithium battery - life-time depends upon settings and configuration - up to 5 years. (requires PD, PL or PX)
<b>Type PC</b>	Intrinsically Safe long life lithium battery life-time depends upon settings and configuration - up to 5 years. (requires XI and PD, PL or PX)
<b>Type PD</b>	16 - 30V DC. power consumption max. 1W.
<b>Type PF</b>	24V AC / DC ± 10%. Power consumption max. 15W.
<b>Type PL</b>	Input loop powered from sensor signal 4 - 20mA (type "A").
<b>Type PM</b>	115 - 230V AC ± 10%. Power consumption max. 15W.
<b>Type PX</b>	8 - 30V DC. Power consumption max. 0.3W.
<b>Type ZB</b>	20 - 30V DC ± 10%. Power consumption max. 1W. With type PF / PM: internally powered.
<b>Note PB/PF/PM</b>	Not available Intrinsically Safe.
<b>Note PF/PM</b>	The total consumption of the sensor, active output type OA and backlight type ZB may not exceed 400mA @ 24V DC.
<b>Note XI</b>	For Intrinsically Safe applications, consult the safety values in the certificate.

## Sensor excitation

<b>Type PB/PC/PX</b>	3.2V DC for pulse signals and 1.2V DC for coil pick-up.
<b>Note PB/PC/PX</b>	This is not a real sensor supply. Only suitable for sensors with a very low power consumption like coils (sine wave) and reed-switches.
<b>Type PD</b>	For pulse signals: 1.2 / 3.2 / 8.2V DC - max. 5mA@8.2V DC. For analog signals, the sensor supply voltage is according to the power supply voltage connected.
<b>Type PF / PM</b>	With pulse input: 1.2 / 3.2 / 8.2 / 12 / 24V DC - max. 400mA @ 24V DC. With analog input: 8.2 / 12 / 24V DC - max. 400mA @ 24V DC.

## Terminal connections

<b>Type</b>	Removable plug-in terminal strip. Wire max. 1.5mm <sup>2</sup> and 2.5mm <sup>2</sup>
-------------	--

## Directives & Standards

<b>EMC</b>	EN 613 26-1, FCC 47 CFR Part 15
<b>Low voltage</b>	EN/IEC 61010-1, CSA C22.2 No.61010-1, UL61010-1
<b>ATEX</b>	EN IEC 60079-0, EN 60079-11
<b>IECEX</b>	IEC 60079-0, IEC 60079-11
<b>CSA</b>	CAN/CSA 22.2 No. 157, ANSI/UL 913 CAN/CSA 22.2 No. 142, UL 508 CAN/CSA 22.2 No. 60079-0, ANSI/ISA 60079-0 CAN/CSA 22.2 No. 60079-11, ANSI/ISA 60079-11
<b>RoHS</b>	EN 50581, IEC 6300
<b>IP &amp; NEMA</b>	EN 60529, ANSI/IEC 60529, NEMA 250

## Intrinsically Safe (Type XI)

<b>ATEX</b>	Gas: II 1 G Ex ia IIC T4 Ga. Dust: II 1 D Ex ia IIIC T <sub>200</sub> 100 °C Da.
<b>IECEX</b>	Gas: Ex ia IIC T4 Ga. Dust: Ex ia IIIC T <sub>200</sub> 100 °C Da.
<b>CSA c-us</b>	IS Class I/II/III, Division 1, Groups A to G T4. Class 1 Zone 0 AEx ia IIC T4 Ga. Ex ia IIC T4 Ga.
<b>Note</b>	Extended aluminum enclosures are not available with CSAc-us approval.
<b>CSA c-us</b>	

## Explosion proof (Type XF)

<b>ATEX/IECEX</b>	Gas: II 2 G Ex db IIB+H2 T5 Gb. Dust: II 2 D Ex tb IIIC T80°C.
<b>Protection</b>	IP66
<b>Type XF</b>	Dimensions of enclosure: 300 x 250 x 200mm (11.8" x 9.9" x 7.9") L x H x D.
<b>Weight</b>	Appr. 15kg.

## Enclosure

<b>Window</b>	Polycarbonate window.
<b>Sealing</b>	Silicone.
<b>Control keys</b>	Three industrial micro-switch keys. UV-resistant silicone keypad.

## Panel mount enclosures

<b>Dimensions</b>	130 x 120 x 60mm (5.12" x 4.72" x 2.36") - W x H x D.
<b>Panel cut-out</b>	115 x 98mm (4.53" x 3.86") L x H.
<b>Type HB</b>	Die-cast aluminum panel mount enclosure IP65 / NEMA Type4X.
<b>Weight</b>	600 gr.
<b>Type HC</b>	GRP panel mount enclosure IP65 / NEMA Type4X, UV-resistant and flame retardant.
<b>Weight</b>	450 gr.
<b>Type HSB</b>	Die-cast stainless steel 316L IP67/NEMA Type4X.
<b>Weight</b>	1150gr.

## Stainless steel 316L wall / field mount enclosures

<b>General</b>	Die-cast stainless steel 316L wall/field mount enclosure with flat bottom. IP67/NEMA Type4X.
<b>Dimensions</b>	130 x 120 x 75mm (5.12" x 4.72" x 2.95") - W x H x D.
<b>Weight</b>	2700 gr.
<b>Type HSM</b>	Cable entry: 2 x M16 + 1 x M20.
<b>Type HSO</b>	Cable entry: 2 x M20.
<b>Type HSU</b>	Cable entry: 3 x ½"NPT.

## Aluminum wall / field mount enclosures

<b>General</b>	Die-cast aluminum wall/field mount enclosure IP67 / NEMA Type4X with 2-component UV-resistant coating. Extended back cover available with undrilled preparation for direct meter mounting.
<b>Dimensions</b>	130 x 120 x 75mm (5.12" x 4.72" x 2.95") - W x H x D. 130 x 120 x 90mm (5.12" x 4.72" x 3.54") - W x H x D.
<b>Weight</b>	1100 gr. / extended enclosure: 1310 gr.
<b>Type HA</b>	Cable entry: 2 x PG9 and 1 x M20.
<b>Type HL</b>	Cable entry: 2 x 1/2" NPT.
<b>Type HM/HBM</b>	Cable entry: 2 x M16 and 1 x M20.
<b>Type HN</b>	Cable entry: 1 x M20.
<b>Type HO/HBO</b>	Cable entry: 2 x M20.
<b>Type HP</b>	Cable entry: 6 x M12.
<b>Type HT</b>	Cable entry: 1 x 1/2" NPT.
<b>Type HU/HBU</b>	Cable entry: 3 x 1/2" NPT.
<b>Type HV</b>	Cable entry: 4 x M20.
<b>Type HZ</b>	Cable entry: no holes.
<b>Note</b>	Extended aluminum enclosures are not available with CSAC-us and FM approvals.
<b>CSA c-us/FM</b>	

## GRP wall / field mount enclosures

<b>General</b>	GRP wall/field mount enclosure IP67 / NEMA Type4X, UV-resistant and flame retardant.
<b>Dimensions</b>	130 x 120 x 75mm (5.12" x 4.72" x 2.95") - W x H x D.
<b>Weight</b>	600 gr.
<b>Type HD</b>	Cable entry: no holes.
<b>Type HE</b>	Cable entry: 2 x Ø 16mm and 1 x Ø 20mm.
<b>Type HF</b>	Cable entry: 1 x Ø 22mm (7/8").
<b>Type HG</b>	Cable entry: 2 x Ø 20mm.
<b>Type HH</b>	Cable entry: 6 x Ø 12mm.
<b>Type HJ</b>	Cable entry: 3 x Ø 22mm (7/8").
<b>Type HK</b>	Flat bottom, cable entry: no holes.
<b>Type HQ</b>	Cable entry: 1 x Ø 20mm, 1 x Ø 16mm & 3 x Ø 12mm

## Signal inputs - Flowmeter

<b>Type P</b>	Coil / sine wave (HI: 20mVpp or LO: 90mVpp - sensitivity selectable), NPN/PNP, open collector, reed switch, Namur, active pulse signals 8 - 12 and 24V DC.
<b>Frequency</b>	Minimum 0Hz - maximum 6kHz for total and flow rate. Maximum frequency depends on signal type and internal low-pass filter. E.g. reed switch with low-pass filter: max. frequency 120Hz.
<b>K-Factor</b>	0.000010 - 9,999,999 with variable decimal position.
<b>Low-pass filter</b>	Available for all pulse signals.
<b>Option ZF</b>	coil sensitivity 10mVpp.
<b>Option ZG</b>	coil sensitivity 5mVpp.
<b>Type A</b>	(0)4 - 20mA. Analog input signal can be scaled to any desired range within 0 - 20mA.
<b>Type U</b>	0 - 10V DC. Contact factory.
<b>Accuracy</b>	Resolution: 16 bit. Error < 0.01mA / ± 0.05% FS. Low level cut-off programmable.
<b>Span</b>	0.0010 - 999,999 with variable decimal position.
<b>Update time</b>	Four times per second.
<b>Voltage drop</b>	Type A: max. 1V DC @ 20mA.
<b>Voltage drop</b>	Type A - PL (loop powered): max. 2.6V DC @ 20mA.
<b>Relationship</b>	Linear and square root calculation.
<b>Note A</b>	For signal type A: external power to sensor is required; e.g. type PD.

## Signal output - Digital output

<b>Function</b>	Pulse output - transmitting accumulated total.
<b>Frequency</b>	Max. 500Hz. Pulse width user definable between 1msec up to 10 seconds.
<b>Type OA</b>	One active 24V DC transistor output (PNP); load max. 400mA (requires PF or PM).
<b>Type OR</b>	One electro-mechanical relay output - isolated; max. switch power 230V AC (N.O.) - 0.5A (requires PF or PM).
<b>Type OT</b>	One passive transistor output (NPN) - not isolated. Max. 50V DC - 300mA per output.

## Data protection

<b>Type</b>	EEPROM backup of all settings. Backup of running totals every minute. Data retention at least 10 years.
<b>Password</b>	Configuration settings can be password protected.

## Operator functions

<b>Displayed info</b>	<ul style="list-style-type: none"> <li>• Flow rate and / or total.</li> <li>• Total and accumulated total.</li> <li>• Total can be reset to zero by pressing the CLEAR-key twice.</li> </ul>
-----------------------	--

## Total

<b>Digits</b>	7 digits.
<b>Units</b>	L, m <sup>3</sup> , GAL, USGAL, kg, lb, bbl, no unit.
<b>Decimals</b>	0 - 1 - 2 or 3.
<b>Note</b>	Total can be reset to zero.

## Accumulated total

<b>Digits</b>	11 digits.
<b>Units / Decimals</b>	According to selection for total.
<b>Note</b>	Can not be reset to zero.

## Flow rate

<b>Digits</b>	7 digits.
<b>Units</b>	mL, L, m <sup>3</sup> , Gallons, kg, Ton, lb, bl, cf, RND, ft <sup>3</sup> , scf, Nm <sup>3</sup> , NI, ical - no units.
<b>Decimals</b>	0 - 1 - 2 or 3.
<b>Time units</b>	/sec - /min - /hr - /day.

## Mounting accessories

<b>ACF02</b>	Stainless steel wall mounting kit.
<b>ACF05</b>	Stainless steel pipe mounting kit (worm gear clamps not included).
<b>ACF06</b>	Two stainless steel worm gear clamps Ø 44 - 56mm.
<b>ACF07</b>	Two stainless steel worm gear clamps Ø 58 - 75mm.
<b>ACF08</b>	Two stainless steel worm gear clamps Ø 77 - 95mm.
<b>ACF09</b>	Two stainless steel worm gear clamps Ø 106 - 138mm.
<b>ACF11</b>	Swivel with 25° movement from center axis for direct flowmeter mounting: 1" NPT to 1/2" NPT.

		Description
Model	<b>F014</b>	<b>Flow rate indicator / totalizer with pulse signal output.</b>
Input	A	(0)4 - 20mA input.
	<b>P</b>	<b>Pulse input, e.g., coil, npn, pnp, namur.</b>
Enclosures	HB	Aluminum panel mount enclosure.
	<b>HC</b>	<b>GRP panel mount enclosure.</b>
	HSB	Stainless steel 316L panel mount enclosure.
	HD	GRP field mount - Cable entry: no holes.
	HE	GRP field mount - Cable entry: 2 x Ø 16mm & 1 x Ø 20mm.
	HF	GRP field mount - Cable entry: 1 x Ø 22mm (7/8").
	HG	GRP field mount - Cable entry: 2 x Ø 20mm.
	HH	GRP field mount - Cable entry: 6 x Ø 12mm.
	HJ	GRP field mount - Cable entry: 3 x Ø 22mm (7/8").
	HK	GRP field mount, flat bottom - Cable entry: no holes.
	HQ	GRP field mount - Cable entry: 1 x Ø 20mm, 1 x Ø 16mm & 3 x Ø 12mm.
	HA	Aluminum field mount - Cable entry: 2 x PG9 + 1 x M20.
	HL	Aluminum field mount - Cable entry: 2 x 1/2"NPT.
	HM	Aluminum field mount - Cable entry: 2 x M16 + 1 x M20.
	HN	Aluminum field mount - Cable entry: 1 x M20.
	HO	Aluminum field mount - Cable entry: 2 x M20.
	HP	Aluminum field mount - Cable entry: 6 x M12.
	HT	Aluminum field mount - Cable entry: 1 x 1/2"NPT.
	HU	Aluminum field mount - Cable entry: 3 x 1/2"NPT.
	HV	Aluminum field mount - Cable entry: 4 x M20.
	HZ	Aluminum field mount - Cable entry: no holes.
	HBM	Extended Alu. field/meter mount - Cable entry: 2 x M16 + 1 x M20 (not with CSAc-us approval).
	HBO	Extended Alu. field/meter mount - Cable entry: 2 x M20 (not with CSAc-us approval).
	HBU	Extended Alu. field/meter mount - Cable entry: 3 x 1/2"NPT (not with CSAc-us approval).
	HSM	Stainless steel 316L field mount - Cable entry: 2 x M16 + 1 x M20.
	HSO	Stainless steel 316L field mount - Cable entry: 2 x M20.
	HSU	Stainless steel 316L field mount - Cable entry: 3 x 1/2"NPT.
	Digital output	OA
OR		One mechanical relay output - requires XX and PF or PM.
<b>OT</b>		<b>One passive transistor output.</b>
Power	PD	16 - 30 V DC + sensor supply.
	PF	24V AC/DC + sensor supply - requires XX.
	PL	Input loop powered from sensor signal type "A".
	PM	115 - 230V AC + sensor supply - requires XX.
	<b>PX</b>	<b>Basic power supply 8 - 30V DC.</b>
Battery	PB	Additional lithium battery powered (opt.) - requires XX and PD, PL or PX.
	PC	Additional lithium battery powered (opt.) - Intrins. safe - requires XI and PD, PL or PX.
Hazardous	XI	Intrinsically safe, according ATEX, IECEx and CSA c-us.
	XF	Ex d enclosure - 3 keys according ATEX and IECEx.
	<b>XX</b>	<b>Safe area only, according CE / UKCA.</b>
Options	ZB	Backlight.
	ZF	Coil input 10mVpp.
	ZG	Coil input 5mVpp.
	<b>ZX</b>	<b>No options.</b>

The **bold** marked text contains the standard configuration: F014-P-HC-OT-PX-XX-ZX.