

Instruction Manual

Flow Measurement Transmitter

NivuFlow 750/700



Firmware Revision: 3.8.x / 4.4.x

Revised Instruction Manual

Document Revision 03 / 29.08.2025

Original Instruction Manual: German / Rev. 03 as of 27.08.2024

measure analyse optimise

NIVUS AG, Switzerland

Burgstrasse 28
8750 Glarus, Switzerland
Phone +41 55 6452066
Fax +41 55 6452014
info@nivus.ch
www.nivus.ch

NIVUS, Austria

Mühlbergstraße 33B
3382 Loosdorf, Austria
Phone +43 2754 5676321
Fax +43 2754 5676320
austria@nivus.com
www.nivus.de

NIVUS Sp. z o.o., Poland

Ul. Bolesława Krzywoustego 4
81-035 Gdynia, Poland
Phone +48 58 7602015
biuro@nivus.pl
www.nivus.pl

NIVUS France SAS, France

28 rue de Londres
75009 Paris, France
Phone +33 1 89708767
info@nivus.fr
www.nivus.fr

NIVUS Ltd., United Kingdom

Unit 2D Middlemarch 4020
Middlemarch Business Park
Siskin Parkway East
Coventry, CV3 4SU
Phone +44 8445 332883
nivusUK@nivus.com
www.nivus.co.uk

NIVUS Middle East (FZE)

Prime Tower
Business Bay Dubai
31st floor, office C-3
P.O. Box: 112037
Phone +971 4 4580502
middle-east@nivus.com
www.nivus.com

NIVUS Korea Co. Ltd.

#2301, M-Dong Technopark IT Center,
32 Songdogwahak-ro, Yeonsu-gu,
INCHEON, Korea 21984
Phone +82 32 2098588
Fax +82 32 2098590
jhwon@nivuskorea.com
www.nivuskorea.com

NIVUS Vietnam

237/78 Phan Trung Street
Tan Tien Ward, Bin Hoa City
Dong Nai Province, Vietnam
Phone +84 94 2623979
jhwon@nivuskorea.com
www.nivus.com

NIVUS Africa

3rd floor, block no. 3
75th Fadan Area
Abo Rawash Industrial Zone
Giza, Egypt
Phone +20 2 35393975
Fax +20 2 35393976
sales@nivusaf.com
www.nivus.com

NIVUS Technologies India Pvt. Ltd.

600032 Chennai
Tamil Nadu
India
Phone +91 44 40652811
india@nivus.com
www.nivus.in

Copyrights and Property Rights

The contents of this document including tables and drawings are proprietary to NIVUS GmbH and are not to be reproduced or copied without express written permission.

Violations oblige to compensation.



Important Notice

This instruction manual - even in parts - may exclusively be copied or translated in any other way with the express written consent of NIVUS GmbH.

Translation

If the device is sold to a country in the European Economic Area (EEA) this instruction manual must be translated into the language of the country in which the device is to be used .

Should the translated text be unclear, the original instruction manual (German) must be consulted or a member company of the NIVUS group must be contacted for clarification.

Copyright

No part of this publication may be reproduced, transmitted, sold or disclosed without prior permission. All rights reserved.

Names

The use of general descriptive names, trade names, trademarks and the like in this manual does not entitle the reader to assume they may be used freely by everyone. They are often protected registered trademarks even if not marked as such.

Revision History

Rev.	Modifications	Editor	Date
03	Cover: Firmwarerevision extended; Addresses updated; Chap. "43.2 Web Server": Info texts to HTTP and FTP added; Chap. "Approvals and Certificates" updated	MoG	29.08.2025
02	Firmwareversion updated; Addresses updated; General: contents supplemented at the appropriate places by the types G1, GR, G3 and G9; Chap. "17 Specifications", "18.1 Device Versions", "18.2 Add-On Function Licences", "19 Areas of Use", "20.2.1 External Level Sensor" and "21.5 Fastening the field enclosure and preparations for electrical installation" updated/supplemented; Fig. 22-6 updated; Chap. "22.4 Relay", "23.4 Connecting Sensors to NivuFlow" and "25.1 General" supplemented; Chap. "25.2 Connecting the Flow Velocity Sensors" and "25.3 Connecting the Level Sensors" updated; Chap. "25.5 Basic structure of multi-measurement places (via Modbus coupling)" added; Chap. "26 Overvoltage Protection Measures" supplemented; Fig. 28-1 updated; Chap. "29 General Overview", "39.1.3 Channel Profiles", "39.1.8 Stability", "39.2.1 h-Sensor Types", "39.2.2 Definition of Measurement Ranges", "39.2.3 Overlapping", "39.3.3 Mounting Position of Sensors", "39.3.5 v-Determination low Levels" "39.4.1 Analogue Inputs", "39.4.2 Analogue Outputs", "39.4.4 Digital Outputs", "39.5 Setting Parameters of the Flow Controller (Q-Controller)", "40.3 Calculation" and "41.4 USB Stick" updated/supplemented; Chap. "41.5.2 Cycle Mode / Clock Control" updated/supplemented; Chap. "42.5 Service": structure adapted; Chap "42.5.3 Feature Unlock", "42.5.7 Disable Coin Cell", "43 Parameter Menu Communication", "45.4 Baud Rate (all Types)" and "47 Diagnostics h-Sensors" updated; Chap. "51 Diagnostics Flow Profile" supplemented; Chap. "57 Accessories" updated/supplemented; minor changes in text and layout	MoG	03.07.2024
01	Complete revision: addition of various features and functions such as Type M9, regulator operation, integrated mobile communications modem and cyclic operation, layout modifications etc.	MoG	22.06.2021
00	New Creation	DMR	21.07.2015

Tab. 1 Modifications Overview

Table of Contents

COPYRIGHTS AND PROPERTY RIGHTS	3
REVISION HISTORY	4
GENERAL	11
1 About this Manual	11
1.1 Applicable Documentation	11
1.2 Signs and Definitions used	12
1.3 Abbreviations used	12
2 Connections and Control Elements	12
2.1 Power Supply	12
2.2 NivuFlow Control Elements	13
2.3 Tasks of the control elements	13
2.4 Interfaces	14
SAFETY INSTRUCTIONS	15
3 General: Used Symbols and Signal Words	15
3.1 Information on the Valuation of Accident Levels	15
3.2 Warning Notices on the Device (optional)	16
4 Special safety and Precautionary Measures	16
5 Warranty	17
6 Disclaimer	17
7 Intended Use	18
8 Ex Protection	18
9 Duties of the Operator	19
10 Requirements for the Personnel	20
DELIVERY, STORAGE AND TRANSPORT	21
11 Scope of Delivery	21
12 Inspection upon Receipt	21
13 Storage	21
14 Transport	21
15 Return	21

PRODUCT SPECIFICATION	22
16 Product Construction and Overview	22
16.1 Enclosure Dimensions	23
16.2 Connectable Sensors	24
16.3 Device ID	25
17 Specifications	26
18 Equipment	28
18.1 Device Versions	28
18.2 Add-On Function Licences	29
FUNCTIONAL DESCRIPTION	30
19 Areas of Use	30
20 Functional Principles	31
20.1 Flow Velocity Measurement	31
20.1.1 Cross Correlation	31
20.2 Level Measurement	33
20.2.1 External Level Sensor	33
20.2.2 Water-Ultrasound	34
20.2.3 Pressure	35
INSTALLATION AND CONNECTION	36
21 General Mounting Instructions	36
21.1 Avoiding electrostatic discharge (ESD)	36
21.2 Installation/Mounting Variants	36
21.3 Selecting the Mounting Place	38
21.4 Fastening the transmitter to a DIN rail in the control cabinet	38
21.5 Fastening the field enclosure and preparations for electrical installation	38
22 Electrical Installation	40
22.1 Connection to the spring-cage terminal blocks	41
22.2 Terminal Wiring Diagrams	42
22.3 Connecting the Power Supply	46
22.3.1 DC Power Supply	46
22.3.2 Power Supply AC	47
22.4 Relay	48
23 Installation and Connection of Sensors	48
23.1 Sensor Installation Principles	48
23.2 Cables and Cable Lengths for Sensor Connection	49
23.3 Connection of iXT and MPX	50
23.4 Connecting Sensors to NivuFlow	53
23.4.1 Connection of Flow Velocity Sensors	53
23.4.2 Connecting Level Sensors	55

23.4.3	Special features for the connection of sensors in Ex area Zone 1	55
24	Controller Mode	56
24.1	General	56
24.2	Construction of a Control Section	58
24.3	Wiring Diagrams for Controller Mode	59
24.4	Control Algorithm.....	60
25	Special Functions of the NivuFlow 750 Type M9/G9	61
25.1	General	61
25.2	Connecting the Flow Velocity Sensors.....	62
25.3	Connecting the Level Sensors	64
25.4	Connecting the Ex Separation Module/Multiplexer to NivuFlow 750 Type M9/G9 transmitter.....	65
25.5	Basic structure of multi-measurement places (via Modbus coupling).....	66
26	Overvoltage Protection Measures	68
COMMISSIONING		74
27	Notes to the User	74
28	Principles of Operation	75
28.1	Overview Display	75
28.2	Using the Control Elements	75
28.3	Input via Keypad	77
28.4	Input via Numeric field.....	78
28.5	Input Correction.....	78
28.6	Menus	79
MAIN SCREEN		80
29	General Overview	80
30	Display Field Flow	82
31	Display Field Level (except combi measurement place NF 750 Type M9/G9)	83
32	Display Field Velocity (except combi measurement place NF 750 Type M9/G9)	84
33	Display Field Temperature (except combi measurement place NF 750 Type M9/G9)	85
34	Display Field Total	85
35	Display Field Trend/Hydrograph	86
36	Display Field Measurement Place of Combi Measurement Place (with NF 750 Type M9/G9 with several Measurement Places)	86

SETTING PARAMETERS

88

37 Basics	88
37.1 Save Parameters	88
37.2 Change Password.....	89
38 Parameter Functions	89
38.1 Main Menu	89
38.2 Functions of the first Menu Level	90
38.2.1 Menu - Application.....	90
38.2.2 Menu - Data.....	91
38.2.3 Menu - System	91
38.2.4 Menu - Communication	92
38.2.5 Menu - Display.....	93
38.2.6 Menu - Connections	93
39 Parameter Description	93
39.1 Setting the Measurement Place Parameters (Menu Application).....	93
39.1.1 Active/Activation of Measurement Places (only for NivuFlow 750 Type M9/G9 with multiple measurement places)	94
39.1.2 Measurement Place Name	94
39.1.3 Channel Profiles	95
39.1.4 Sludge Level.....	101
39.1.5 3D Preview	101
39.1.6 Low-flow suppression.....	101
39.1.7 Damping	102
39.1.8 Stability	102
39.2 Setting Parameters in Menu h-Sensors	103
39.2.1 h-Sensor Types	103
39.2.2 Definition of Measurement Ranges	105
39.2.3 Overlapping	109
39.2.4 Deviation (abs.)	109
39.2.5 Fallback	110
39.3 Setting Parameters in Menu v-Sensors	110
39.3.1 Number of Flow Velocity Sensors	110
39.3.2 Sensor Types.....	111
39.3.3 Mounting Position of Sensors.....	112
39.3.4 Weighting.....	117
39.3.5 v-Determination low Levels	118
39.3.6 Limiting the Velocity Evaluation.....	119
39.3.7 Data Transmission Rate	120
39.4 Setting Parameters of Inputs and Outputs (analogue and digital)	121
39.4.1 Analogue Inputs	121
39.4.2 Analogue Outputs.....	123
39.4.3 Digital Inputs.....	126
39.4.4 Digital Outputs.....	128

39.5	Setting Parameters of the Flow Controller (Q-Controller)	134
39.6	Diagnostics	137
40	Parameter Menu Application/Combi	137
40.1	General Information	137
40.2	Measurement Place Name	138
40.3	Calculation	138
40.4	Damping	139
40.5	Stability	139
41	Parameter Menu Data	139
41.1	Trend	140
41.2	Total	141
41.3	Day Totals	142
41.4	USB Stick	144
41.5	Data Memory (Internal)	149
41.5.1	Basic Functions	149
41.5.2	Cycle Mode / Clock Control	150
41.6	Operating Hours	156
42	Parameter Menu System	157
42.1	Information	157
42.2	Country Settings	157
42.2.1	(Operating) Language	158
42.2.2	Date Format	158
42.2.3	Units	158
42.2.4	Data Units	159
42.3	Time/Date	161
42.4	Error Messages	162
42.5	Service	162
42.5.1	Service Level	163
42.5.2	Change (System) Password	163
42.5.3	Feature Unlock	163
42.5.4	Restart	164
42.5.5	Restart Measurement	164
42.5.6	Parameter Reset	164
42.5.7	Disable Coin Cell	165
42.5.8	Update NivuFlow	166
42.5.9	Update v-Sensor	166
42.5.10	Update h-Sensor	166
43	Parameter Menu Communication	167
43.1	TCP/IP	167
43.2	Web Server	168
43.3	Data Transmission	170
43.4	Alarm	175
43.5	HART	176

43.6	Modbus	177
44	Parameter Menu Display.....	179
45	Parameter Menu Connections	182
45.1	General	182
45.2	For Transmitters Type S1/G1/SR/GR/M3/G3.....	182
45.3	For Transmitters Type M9/G9	183
45.4	Baud Rate (all Types).....	186
 DIAGNOSTICS		 187
46	Basics of the Diagnostics Menu	187
47	Diagnostics h-Sensors	188
48	Diagnostics v-Sensors.....	189
49	Diagnostics Inputs and Outputs (analogue and digital).....	192
49.1	Analogue Inputs	192
49.2	Analogue Outputs	193
49.3	Digital Inputs	194
49.4	Digital Outputs.....	194
50	Diagnostics Flow Controller (Q-Controller)	196
51	Diagnostics Flow Profile.....	197
52	Diagnostics Simulation.....	198
 MAINTENANCE AND CLEANING		 200
53	Maintenance.....	200
53.1	Maintenance Interval.....	200
53.2	Customer Service Information.....	200
54	Cleaning	201
54.1	Transmitter	201
54.2	Transducers	201
55	Dismantling/Disposal.....	201
56	Installation of Spare Parts and Wearing Parts.....	202
57	Accessories	203
 INDEX		 204
 OPEN SOURCE SOFTWARE		 208
58	List of Sources of the Licences and Codes used	208
 APPROVALS AND CERTIFICATES		 209

General

1 About this Manual



Important Notice

READ CAREFULLY BEFORE USE!

KEEP IN A SAFE PLACE FOR LATER REFERENCE.

This instruction manual is for the transmitters NivuFlow 750 and NivuFlow 700 (special design, not for German-speaking countries) and serves their intended use. This instruction manual is oriented exclusively to qualified expert personnel.

Read this instruction manual carefully and completely prior to installation or connection since it contains relevant information on this product. Observe the notes and particularly follow the warning notes and safety instructions.

If you should have problems to understand information contained within this instruction manual either contact a member company of the NIVUS group or one of the distributors for further support. The member companies of the NIVUS group cannot be held responsible for damage to persons or material due to incorrectly understood information in this instruction.



Note

For the sake of simplicity, only the NivuFlow 750 is usually mentioned in these operating instructions; the data, drawings and explanations are also always valid for the flow transmitter NivuFlow 700. Provided that it has the equipment and functionalities mentioned.

Depending on the equipment/transmitter type, the descriptions and display illustrations may differ from those shown in the instruction manual.

The NivuFlow 750 Type M9/G9 transmitters have special equipment in the form of multiple measurement places or a combi measurement place; a controller function may be available with the NivuFlow 750 Type SR/GR/M3/G3/M9/G9 transmitters. The illustrations and descriptions for these equipments are not valid for the other transmitter types.



1.1 Applicable Documentation

For the installation and operation of the complete system extra instruction manuals or technical descriptions may be required apart from this instruction manual.

- Technical Description for Correlation Sensors and Electronic Box
- Mounting Instruction Cross Correlation and Doppler Sensors
- Technical Description Ex Separation Module iXT
- Technical Description Multiplexer MPX
- Instruction manual for i-Series sensors and software HART PC
- Technical Information USB Hart Modem
- Technical Description NIVUS MODBUS TCP/RTU Application Interface for NivuFlow series 5xx, 6xx, 7xx, Energy Saver and NivuParQ 850 Transmitters

These manuals are provided with the auxiliary units or sensors and/or are available as download on the NIVUS homepage.

1.2 Signs and Definitions used

Representation	Meaning	Remarks
	(Action) Step	Execute action steps. Should action steps be numbered observe the specified order of the steps.
	Cross-reference	Refers to further or more detailed information.
	Documentation Reference	Refers to an accompanying documentation.
>Text<	Parameter or menu	Indicates a parameter or a menu that is to be selected or is described.

Tab. 2 Structural elements within the manual

1.3 Abbreviations used

Colour code for wires, single conductors and components

The abbreviations of colours for wire and single conductor labelling follow the international colour code according IEC 60757.

BK	Black	BN	Brown	RD	Red
OG	Orange	YE	Yellow	GN	Green
BU	Blue	VT	Violet	GY	Grey
WH	White	PK	Pink	TQ	Turquoise
GNYE	Green/Yellow	GD	Gold	SR	Silver

2 Connections and Control Elements

2.1 Power Supply

The connection for the power supply of the transmitter is located in the lower area of the terminal strip X1.

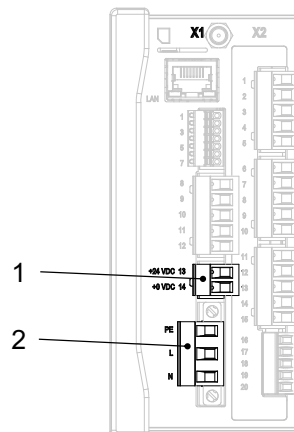

- 1 Power Supply DC/DL
- 2 Power Supply AC and Protective Earth Connection

Fig. 2-1 Power supply terminal clamps

 A detailed wiring diagram can be found in Chapter “22.2 Terminal Wiring Diagrams”.

2.2 NivuFlow Control Elements

The entire parameterisation is menu-driven. The graphics of the display support you with this. The rotary pushbutton and the two function keys are used to select the individual menus and submenus.

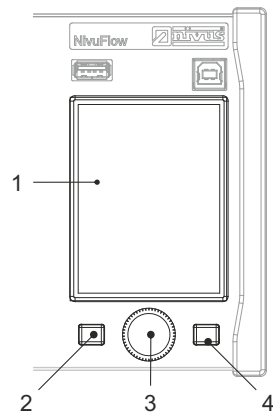

- 1 Colour Display
- 2 Left Function Key
- 3 Rotary Pushbutton
- 4 Right Function Key

Fig. 2-2 Control Elements

2.3 Tasks of the control elements

Colour Display

You can read off all settings during parameterisation and diagnostics.

Left Function Key (Menu or Back)

Press this key (Menu) to go from the main display to the main menu. The same key (Back) is also needed to exit the main menu and the submenus.

Rotary Pushbutton

Use the rotary pushbutton to access the individual submenus. The functions are also controlled via the rotary pushbutton.

- Selection of the desired parameter or menu
- Navigation through the submenus and settings
- Selection of letters or numbers for parameterisation

Right Function Key (Enter or Tab)

Use this key to confirm the entry of values (via numeric keypad or alphabetic keypad).

For some parameters, the right function key serves as a >Tab<. This Tab function is always present when digits are visible at the top right of the display. Then the Tab function is used to switch between pages/displays. This applies for the settings below:

- Menu >Application<
 - Selection of v-Sensors (only with NivuFlow 750 Type M3/G3/M9/G9)
 - v-Sensors diagnostics (only with NivuFlow 750 Type M3/G3/M9/G9)
 - Selection of Analogue Inputs
 - Selection of Analogue Outputs
 - Selection of digital inputs

- Selection of digital outputs
 - Menu >Data< (only with NivuFlow 750 Type M9/G9)
 - Selection of display for trend, total and daily totals for measurement place 1/2/3 and combined measurement place
 - Main screen (only for NivuFlow 750 Type M9/G9)
 - Selection of screen for measurement place 1/2/3 and combi measurement place
- ⇒ A description of how to use the control elements can be found in Chapter “28 Principles of Operation”.

2.4 Interfaces

The transmitter has multiple interfaces on the front of the device.

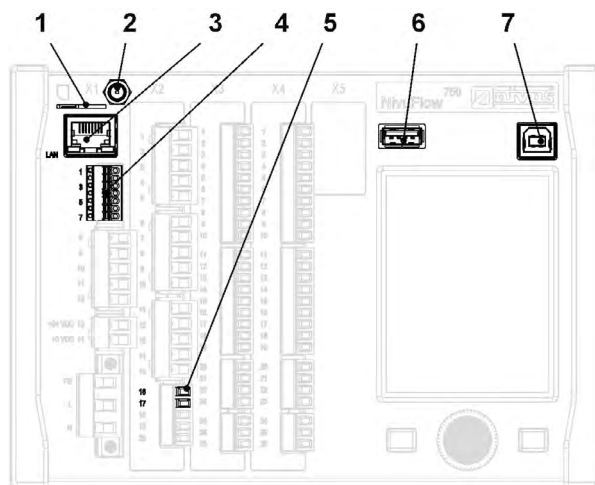

- 1 Slot for SIM card (alternative data transmission via internal 2G/3G/4G modem, only with Type G1/GR/G3/G9)
- 2 Antenna socket (for internal 2G/3G/4G modem; only with Type G1/GR/G3/G9)
- 3 Network Interface (LAN)
- 4 BUS Interface (RS485/RS232)
- 5 Analogue input with HART functionality
- 6 USB-A Interface (data transfer, parameter backup, device update)
- 7 USB-B Interface (service mode)

Fig. 2-3 Available interfaces

- ⇒ A description of the individual interfaces can be found in Chapter “43 Parameter Menu Communication”.

Safety Instructions

3 General: Used Symbols and Signal Words

3.1 Information on the Valuation of Accident Levels



The general warning symbol indicates the risk of personal injuries or death. In the text section the general warning symbol is used in combination with the signal words described below.

DANGER

Warning in high degree of risk



Indicates a high-risk, **imminently** hazardous situation which will result in death or serious injury if not avoided.

WARNING

Warning in medium degree of risk and personal injury



Indicates a **possible** danger with medium risk which may result in a life-threatening situation or (severe) bodily injury if not avoided.

CAUTION

Warning in personal injury or property damage



Indicates a possible danger with moderate risk which may result in minor or moderate personal injury or property damage if not avoided.

WARNING

Danger by electric voltage



Indicates a medium-risk, **imminently** hazardous situation caused by electric shock which will result in death or (serious) injury if not avoided.



Important Notice

Contains information that needs to be highlighted.

Indicates a potentially harmful situation that may damage the product or something in its environment if not avoided.



Note

Contains tips or information.

3.2 Warning Notices on the Device (optional)



General Warning Notice

This symbol refers the operator or user to content in this instruction manual.

Consideration of the information contained herein is necessary to maintain the protection provided by the unit for installation and in operation.



Protective earth connection

This symbol refers to the protective conductor terminal of the device.

Depending on the type of installation, the unit may only be operated with a suitable protective earth connection in accordance with applicable laws and regulations.

4 Special safety and Precautionary Measures

When working with the NIVUS equipment, the following safety and precautionary measures must be observed and followed generally and at all times. These warnings and notes are not repeated for each description within the document.

WARNING



Check danger due to explosive gases

Before starting assembly, installation and maintenance work, be sure to check that all regulations on safety at work have been observed and that there is no possible risk of explosive gases. Use a gas warner for the check.

When working in the sewer system, make sure that no electrostatic charge can occur:

- *Avoid unnecessary movements to reduce the building-up of static charges.*
- *Discharge any static electricity present on your body before you start installing the sensor.*

Disregarding may result in personal injury or damage to the system.

WARNING



Germ Contamination

Particularly due to the use of the sensors in the waste water sector, parts can be contaminated with dangerous germs. Therefore, appropriate precautions must be taken when coming into contact with cables and sensors.

Wear protective clothing.

WARNING



Observe Occupational Safety Regulations!

Before and during mounting works, compliance with all work safety regulations must always be ensured.

Disregarding may lead to personal injury.

WARNING



Do not disable Safety Devices!

It is strictly forbidden to disable the safety devices or to change their mode of operation.

Disregarding may result in personal injury or damage to the system.

WARNING



Disconnect the System from Mains Power

Disconnect the system from the mains power before starting maintenance, cleaning and/or repair work (only by qualified personnel).

Disregarding may lead to electric shock.



Commissioning only by qualified Personnel

The entire measuring system may only be installed and commissioned by qualified personnel.

Built-In Backup Battery

The backup battery integrated in the measurement device may only be replaced by NIVUS or personnel authorised by NIVUS. Non-compliance will result in a limitation of the warranty (see Chap. "5 Warranty").

5 Warranty

The device was functionally tested prior to shipping. When used for the intended purpose (see Chap. "7 Intended Use") and in compliance with the instruction manual, the applicable (see Chap. "1.1 Applicable Documentation") and the safety information and instructions contained therein, no functional restrictions are to be expected and flawless operation should be possible.



Please also refer to the following chapter "6 Disclaimer".



Limitation of Warranty

In case of disregarding the safety notes and instructions in this document, the companies of the NIVUS-Group reserve the right to limit the warranty.

6 Disclaimer

The companies of the NIVUS-Group assume no liability

- for consequential damages resulting from a **change** in this document.
The companies of the NIVUS-Group reserve the right to change the contents of this document including this disclaimer without prior notice.
- for personal injury or damage to property resulting from **failure to comply** with the applicable **regulations**. For connection, commissioning and operation of the devices/sensors, all information and higher-level legal regulations of the country (in Germany e.g. the VDE regulations), such as valid Ex regulations as well as the safety and accident prevention regulations applicable to the respective individual case shall be observed.
- for personal injury or damage to property resulting from **improper handling**. For safety and warranty reasons, all work on the equipment that goes beyond the installation and connection measures may only be carried out by NIVUS personnel or by persons or companies authorised by NIVUS.
- for personal injury or damage to property resulting from the operation of the equipment in a technically **faulty** condition.
- for personal injury or damage to property resulting from **improper use**.
- for personal injury or damage to property resulting from **failure to observe the safety instructions** in this instruction manual.

- for missing or incorrect readings due to **improper installation or faulty parameterisation/programming** and for any consequential damage resulting therefrom.

7 Intended Use



Note

The device is intended exclusively for the purpose mentioned below. Any other use beyond this, any conversion or modification of the instrument without written agreement with the companies of the NIVUS-Group is considered improper use.

The companies of the NIVUS-Group are not liable for any damage resulting from this. The operator alone bears the risk.

The transmitter **NivuFlow 750** incl. associated sensors is designed for continuous flow measurement of slightly to heavily polluted media in **part filled and full** canals, pipes and others.

⇒ See also Chap. "20 Functional Principles".

The transmitter **NivuFlow 700** incl. associated sensors is designed for continuous flow measurement of slightly to heavily polluted media in **full** canals and pipes. The NivuFlow 700 is a special design and is not manufactured for German-speaking countries.

⇒ See also Chap. "20 Functional Principles".

The transmitter is designed and produced according to the current state of the art and the recognised safety rules at the time of publication of this document. Nevertheless, risks of personal injury or damage to property cannot be completely ruled out.

The permissible maximum limit values in Chapter "17 Specifications" must be observed. All cases of use deviating from these limit values, which have not been approved by NIVUS GmbH in writing, are excluded from the liability of the NIVUS-Group.

8 Ex Protection

The NivuFlow 750/700 transmitter can be used in conjunction with an Ex Separation Module Type iXT0 and the POA, CS2 and OCL sensors (which must also have Ex approval) as well as with Ex-approved CSM and DSM sensors (in combination with the EBM Electronic Box) for use in areas with Zone 1 explosive atmospheres. Here, the Ex-approved POA, CS2 and OCL sensors or the Ex-approved CSM and DSM sensors (in combination with the EBM Electronic Box) are installed directly in Ex zone 1, while the **transmitter** and the **Ex Separation Module** must be installed in **non-Ex areas**. The **EBM Electronic Box** can be installed directly in the Ex area Zone 1 **with** the associated **Ex approval**; **without** the Ex approval it must be located **outside** the Ex zone.

The connection diagrams can be found in the corresponding technical description / installation instructions for the POA, CS2 and OCL sensors or the CSM and DSM sensors (in combination with the EBM Electronic Box) or the iXT0 Ex Separation Module.

Sensor / Ex Separation Module Approvals



See "Technical Description for Correlation Sensors and external Electronic box" or "Technical Description Ex Separation Module iXT0".



Validity of the Ex Approval

The Ex approval is only valid in conjunction with the corresponding marking on the name-plate of transmitter and the sensors.



Declarations of Conformity and Test Certificates

For installation and commissioning, the declarations of conformity and test certificates of the approving body as well as the applicable national regulations must be strictly observed.

The combination of the NivuFlow transmitter with the Ex Separation Module iXT is exclusively adapted to the NIVUS correlation sensors Type POA, CS2, CSM and DSM, OCL ultrasonic sensor, i-Series sensors i-03/i-06/i-10/i-15 and pressure sensors NivuBar Plus as well as the EBM Electronic Box with regard to the intrinsically safe system evaluation according to EN 60079-25.

When using sensors from other manufacturers, the operator must carry out a system assessment in accordance with EN 60079-25!

The technical data required for this for the Ex Separation Module iXT are specified in the associated EU type examination certificate.

9 Duties of the Operator



Strictly observe and comply with guidelines and requirements

In the EEA (European Economic Area), the national transposition of the Framework Directive (89/391/EEC) as well as the associated individual directives and, in particular, the Directive (2009/104/EC) concerning the minimum safety and health requirements for the use of work equipment by workers at work, as amended, must be observed and complied with. In Germany, the Ordinance on Industrial Safety and Health must be complied with.

Obtain the local operating licence and observe the associated conditions. In addition, you must comply with environmental protection requirements and local legal requirements for the following:

- Safety of personnel (accident prevention regulations)
- Safety of work equipment (protective equipment and maintenance)
- Product Disposal (Waste Management Act)
- Materials Disposal (Waste Management Act)
- Cleaning (Cleaning Agents and Disposal)

Connections

As the operator, before activating the device, make sure that the local regulations (e.g. for the electrical connection) have been observed during installation and commissioning.

Keep the Instruction Manual for future Reference

Keep the instruction manual in a safe place and ensure that it is always available and can be consulted by the user of the product.

Hand over the Instruction Manual

When selling the measurement device, this instruction manual must be handed over with it. The manual is part of the standard delivery.

10 Requirements for the Personnel

Installation, commissioning and maintenance may only be carried out by personnel who fulfil the following conditions:

- Qualified personnel with appropriate training
- Authorisation by plant operator



Qualified Personnel

in the sense of these instructions or the warnings on the product itself are persons who are familiar with the installation, assembly, commissioning and operation of the product and who have the qualifications appropriate to their job, such as

- I. Training and instruction or authorisation to switch circuits and devices/systems on and off, to earth and to label them in accordance with the standards of safety technology.*
 - II. Training or instruction in accordance with safety technology standards in maintenance and use of appropriate safety equipment.*
 - III. First Aid Training*
-

Delivery, Storage and Transport

11 Scope of Delivery

The standard delivery of the NivuFlow 750/700 usually comprises:

- Transmitter Type NivuFlow 750 or 700 according to delivery documents.
- A 2G/3G/4G antenna (only for Type G1/GR/G3/G9): Enclosed as a magnetic base antenna in the case of transmitters for mounting on DIN rails or attached as an adhesive antenna inside the transmitter in the case of transmitters mounted in NIVUS field enclosures.
- The instruction manual with declaration(s) of conformity and with all the necessary information for operating the NivuFlow 750/700 (printed or as a link to the NIVUS download centre).

Check other accessories according to the order and on the basis of the delivery note.

12 Inspection upon Receipt

Check the delivery for completeness and apparent intactness immediately after receipt . Report any transport damage immediately to the delivering carrier. Also send a written report to NIVUS GmbH in Eppingen.

Incomplete deliveries must be addressed in writing within two weeks to your responsible representative or directly to the NIVUS GmbH in Eppingen.



Important Notice

Complaints received later will not be recognised.

13 Storage

Observe the minimum and maximum values for external conditions such as temperature and humidity according to Chap. "17 Specifications".

Protect the instrument from corrosive or organic solvent vapours, radioactive radiation and strong electromagnetic radiation.

Store the device in the original packaging.

14 Transport

Protect the device from strong impacts, shocks, jolts or vibrations.

Transport the device in the original packaging.

Otherwise, the same rules apply with regard to external influences as for storage (see Chap. "13 Storage").

15 Return

In the event of a return, send the unit to NIVUS GmbH in Eppingen carriage paid and in the original packaging.

Items that have not been sufficiently franked will not be accepted!

In general, a return note (incl. RMA return number) must be requested from the NIVUS customer service before returning the goods. Without this RMA number, the incoming goods cannot be assigned accordingly.



See Chap. "53.2 Customer Service Information".

Product Specification

16 Product Construction and Overview

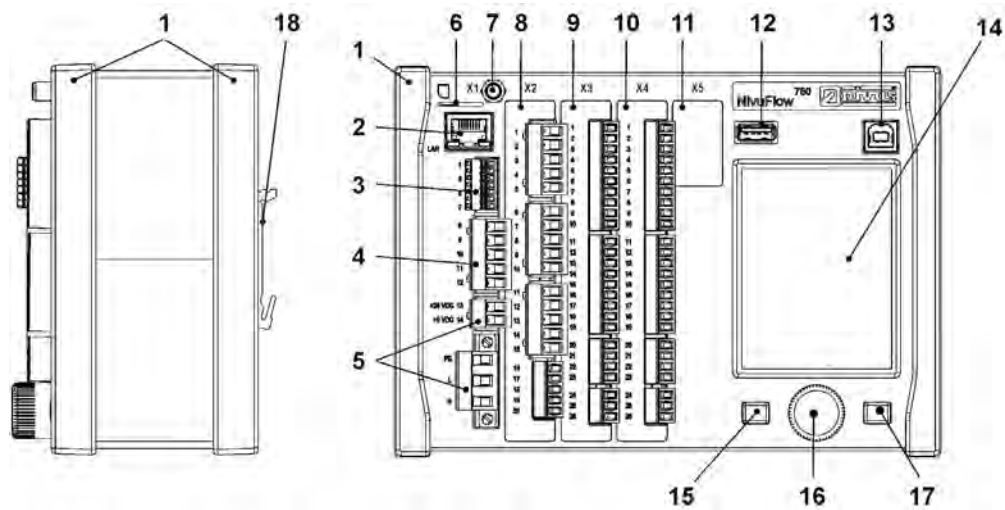

- 1 Cover Strips (only for control cabinet installation; installation variant / enclosure E0)
- 2 Network Interface (LAN)
- 3 Bus Interface (RS485/RS232)
- 4 Connection Air-Ultrasonic Sensor (RS485)
- 5 Power Supply
- 6 Slot for SIM card (alternative data transmission via internal 2G/3G/4G modem, only with Type G1/GR/G3/G9)
- 7 Antenna socket (for internal 2G/3G/4G modem; only with Type G1/GR/G3/G9) (SMA, female)
- 8 Slot X2 - v-Sensor 1 (as well as v-Sensor 2/3 for Type M3/G3/M9/G9)
- 9 Slot X3 - for Type SR/GR/M3/G3/M9/G9
- 10 Slot X4 - for Type M3/G3/M9/G9
- 11 Slot X5 - expansion slot (not used)
- 12 USB-A Interface (data transfer, parameter backup, device update)
- 13 USB-B Interface (service mode)
- 14 Graphic Display
- 15 Function Key
- 16 Rotary Pushbutton
- 17 Function Key
- 18 DIN rail fastening (for installation in NIVUS field enclosures; installation variant / enclosure E1: fastened raised by 6 mm)

Fig. 16-1 Device construction NivuFlow 750/700; installation variants / enclosures: E0/E1

16.1 Enclosure Dimensions

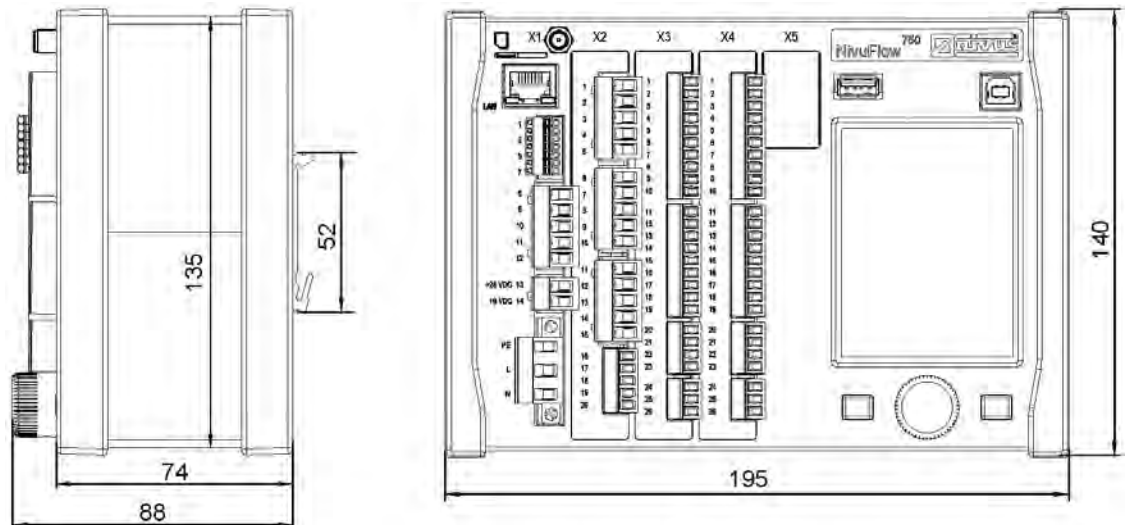
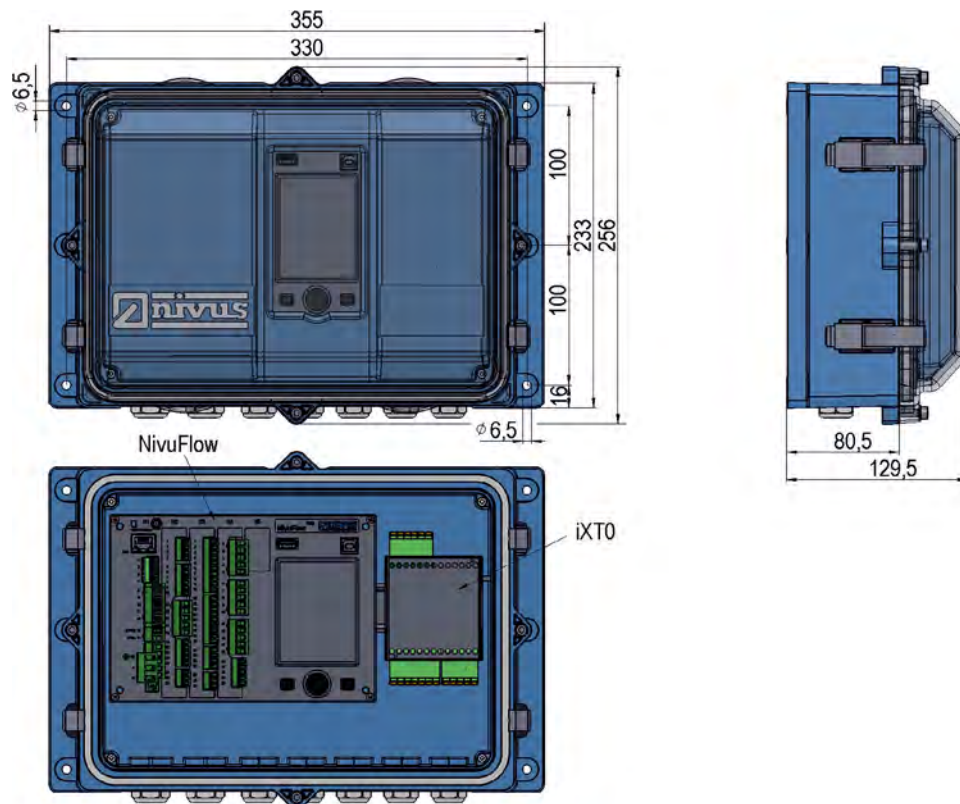

Fig. 16-2 Dimensions NivuFlow 750/700; installation variant / enclosure: E0



Info: Bottom view without cover (NivuFlow and iXT visible)

Fig. 16-3 Dimensions field enclosure NivuFlow (with iXT as option); installation variant / enclosure: E1

16.2 Connectable Sensors

In the following illustration you will find an overview of the directly connectable NIVUS sensors.

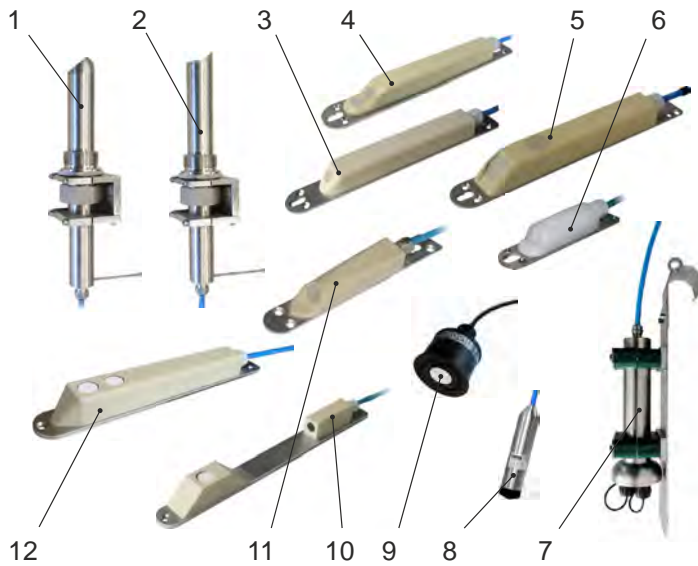

- 1 Pipe sensor, Type CS2 (with sensor screw connection and fastening element)
- 2 Pipe sensor, Type POA (with sensor screw connection and fastening element)
- 3 Flow velocity wedge sensor, Type POA-Vx00/VxD0
- 4 Flow velocity wedge sensor, Type POA-VxH1/VxU1
- 5 Flow velocity wedge sensor, Type CS2
- 6 Mini flow velocity wedge sensor, Type CSM-V100 (connection via EBM required)
- 7 Electronic Box, Type EBM
- 8 Level pressure sensor, Type NivuBar Plus
- 9 i-Series ultrasonic sensor NMI0, Type i-03, i-06, i-10 and i-15
- 10 Ultrasonic level sensor, Type DSM (connection via EBM required)
- 11 Mini flow velocity wedge sensor, Type CSM-V1D0 (connection via EBM required)
- 12 Air-ultrasonic active sensor, Type OCL

Fig. 16-4 Connectable Sensors

16.3 Device ID

The information in this instruction manual only applies to the device type indicated on the title page.

The nameplate is attached to the side of the enclosure and contains the following information:

- Name and address NIVUS GmbH
- CE label
- Marking of the series and type with article number and serial number
- Year of manufacture: the first four digits of the serial number refer to the year of manufacture and the week number (2114.....)
- Power supply (see Article No. and Chap. "18.1 Device Versions")

It is important for all queries and spare parts orders that the article number and serial number of the respective device are specified correctly. This is the only way to ensure proper and fast processing.



Note

Check by means of the nameplates whether the supplied device corresponds with your order.

Check that the correct voltage supply is indicated on the nameplate (bottom left field).



The EU Declaration of Conformity can be found at the end of this instruction manual.

Nameplates (Examples)



Fig. 16-5 Nameplate AC version



Fig. 16-6 Nameplate DC version

17 Specifications

Power Supply	100...240 V AC, -15 % / +10 %, 47...63 Hz or 10...35 V DC
Connection Power Supply	AC: Plugged and screwed on spring-cage terminal block DC/DL: Plugged spring-cage terminal block
Maximum Power Consumption	AC: 30 VA / DC: 20 W
Typical Power Consumption	1x POA-VxU1 + 1x i-Sensor + 1 Relay energised + 1x iXT, 230 V AC: 14 VA / 6.8 W 24 V DC: 6.2 W
Enclosure	DIN Rail Material: Aluminium and Plastic Weight: approx. 1300 g Field Enclosure Material: Polyamide PA / Polycarbonate PC Weight: approx. 4000 g (incl. NF750 and iXT0 211) Dimensions see Chap. 16.1.
Protection	DIN Rail IP20 Field Enclosure IP67 (option IP68)
Operating Conditions	Protection Class I Overvoltage Category II Pollution Degree 2
Application Altitude	AC unit for use at altitudes up to 3000 m above MSL. For relay voltages >150 V, use is restricted to altitudes up to max. 2000 m above MSL (AC and DC units)
Operation Temperature	DC: -20...+70 °C AC: -20...+65 °C
Storage Temperature	-30...+80 °C
Max. Ambient Temp. for Installation and Operation	+50 °C
Max. Humidity	80 %, non-condensing
User Indicator	Daylight-readable TFT colour graphic display, 240x320 pixel, 65536 colours
Setting Parameters/ Programming	Menu-driven using rotary pushbutton and two function keys, in English, German, French, Italian, Spanish, Portuguese, Swedish, Danish, Finnish, Polish, Hungarian, Romanian, Czech, Russian, Korean and Chinese language
Connection	- General: Plugged spring-cage terminal block - AC Power Supply: Plugged and screwed on spring-cage terminal block

Inputs	<ul style="list-style-type: none"> - 1x 4...20 mA for external level (2-wire probe) - 1x 4...20 mA for external level (2-wire probe; HART) - 1x RxTx-Bus for NIVUS air-ultrasonic active sensor (OCL) - 1x (only for Type S1/G1), 4x (only for Type SR/GR) or 7x (only for Type M3/G3/M9/G9) 0/4...20 mA with 12-bit resolution for external level, external control setpoint and data storage of external devices, accuracy $\pm 0.4\%$ of the measured value range (20 mA), load 91 Ohm - 2x (only for Type S1/G1), 7x (only for Type SR/GR) or 10x (only for Type M3/G3/M9/G9) digital input - 1x (only for Type S1/G1/SR/GR), 1...3x (only for Type M3/G3) or 3x (only for Type M9/G9) velocity sensors (POA, CS2 or EBM + CSM) or iXT or MPX connectable
Outputs	<ul style="list-style-type: none"> - 2x (only for Type S1/G1) or 4x (only for Type SR/GR/M3/G3/M9/G9) 0/4...20 mA, load 500 Ohm, 12 bit resolution, accuracy better than $\pm 0.1\%$ at 20 °C (better than $\pm 0.4\%$ at -20...+70 °C) - 1x bistable relay (SPDT) (only for type S1/G1/SR/GR), loadable up to 230 V AC / 2 A (cos φ 0.9), minimum switching current 100 mA - 1x (only for Type S1/G1), 4x (only for Type SR/GR) or 6x (only for Type M3/G3/M9/G9) relay (SPDT), loadable up to 230 V AC / 2 A (cos φ 0.9), minimum switching current 10 mA
Controller	1x 3-step controller, quick close control, adjustable slide valve position in the event of an error (controller only available for Types SR/GR/M3/G3/M9/G9)
Data Memory	Internal 1.0 GB, for parameterisation/programming and measurement backup for approx. 570,000 data sets (time stamps); can be read via front-side USB stick
Storage Cycle	30 seconds to 15 minutes
Communication	<ul style="list-style-type: none"> - Modbus TCP via networks (LAN/WAN) - Modbus RTU via RS485 or RS232 - SMTP/FTP/HTTP - 2G/3G/4G via built-in radio communications modem (only with Type G1/GR/G3/G9)

Tab. 3 Specifications

Transducers



The specifications of the associated sensors can be found in the corresponding instructions or technical descriptions.

18 Equipment

18.1 Device Versions

The NivuFlow is manufactured in different versions and varies mainly in the number of connectable sensors as well as the number of parameterisable measurement places. The article number can be found on the nameplate (see "Nameplates (Examples)" on page 25).



Observe country-specific differences

The transmitter types listed below are not all available in every country.

For details, please contact the companies in the NIVUS group or your local representative.

NF7- Flow measurement transmitter NivuFlow;
function extension through software licences (see Chap. 18.2)

Design

0 Special construction (only in connection with Type S1/G1)

5 For part filled and full pipes, channels and flumes

Type

S1 1x v-Sensor, 1x Air-Ultrasonic OCL, 2x DI, 2x DO, 2x AI, 2x AO

G1 1x v-Sensor, 1x Air-Ultrasonic OCL, 2x DI, 2x DO, 2x AI, 2x AO;
with internal modem; modem card Global; IoT-ready

SR 1x v-Sensor, 1x Air-Ultrasonic OCL, 7x DI, 5x DO, 5x AI, 4x AO,
integrated 3-step controller

GR 1x v-Sensor, 1x Air-Ultrasonic OCL, 7x DI, 5x DO, 5x AI, 4x AO; with internal
modem; modem card Global; IoT-ready; integrated 3-step controller

M3 3x v-Sensor, 1x Air-Ultrasonic OCL, 10x DI, 6x DO, 8x AI, 4x AO,
integrated 3-step controller

G3 3x v-Sensor, 1x Air-Ultrasonic OCL, 10x DI, 6x DO, 8x AI, 4x AO; with internal
modem; modem card Global; IoT-ready; integrated 3-step controller

M9 Via Multiplexer or Ex Separation Module expandable to a maximum of 9x v-sen-
sors and 3x air-ultrasonic sensors OCL; 10x DI, 6x DO, 8x AI, 4x AO; integrated
3-step controller for one measurement place (only in connection with enclosure
E0 and 2/3x iXT/MPX)

G9 Via Multiplexer or Ex Separation Module expandable to a maximum of 9x v-sen-
sors and 3x air-ultrasonic sensors OCL; 10x DI, 6x DO, 8x AI, 4x AO; with internal
modem; modem card Global; IoT-ready; integrated 3-step controller for one meas-
urement place (only in connection with enclosure E0 and 2/3x iXT/MPX)

Construction / Enclosure

E0 DIN rail/control cabinet mounting, IP20

E1 DIN rail, prepared for mounting into NIVUS field enclosure

Power Supply

A0 100...240 V AC

D0 10...35 V DC

DL Clocked cycle and event-based operation, 10...35 V DC

Extension

0 None

1 HART protocol of the analogue output

Number of measurement places

1 1 Measurement place

2 2 Measurement places (only for Type M9/G9,
enclosure: E0)

3 3 Measurement places (only for Type M9/G9,
enclosure: E0)

NF7-						
-------------	--	--	--	--	--	--

Tab. 4 Product Structure

18.2 Add-On Function Licences

The transmitter can be equipped with supplementary functions at extra charge. The following function extensions are currently available as (software) licences:

- Remote data transmission via FTP and E-Mail (required if a customer SIM card is used)
- Clocked operation (cycle mode/clocked control) of permanent NF7 transmitters
- Modbus coupling of up to 3x NFx transmitters to one multi-measurement place device NF7 (Type M9/G9 required)
- Radio Transmission of Data Depth >Extended< (data depth >Standard< works without licence)
- Radio Transmission of Data Depth >Expert< (data depth >Standard< works without licence)



The functions are activated according to Chap. "42.5.3 Feature Unlock".

Functional Description

19 Areas of Use

The NivuFlow 750/700 is a permanent measuring system for flow measurement. The NivuFlow is designed mainly for use in the measurement of slightly to heavily contaminated, aqueous liquids of the most varied compositions.

The NivuFlow 750 is used in part filled and full flumes, channels and pipes of the most varied geometries and dimensions. The NivuFlow 700 only in full pipes.

The SR/GR/M3/G3/M9/G9 device types also have a 3-step controller for controlling a slide valve or another actuator.



An overview on **connectable sensors** can be found in Chapter “16.2 Connectable Sensors”.



More precise detection of the flow velocity

The use of several sensors serves to record the flow velocity more accurately at one common measurement place or, in the case of type M9/G9, for the simultaneous recording of two or three different measurement places.

Depending on the transmitter equipment (see also Chap. “18.1 Device Versions”), the measurement system can be set up in three levels.

- **Level 1 for cross-correlation** (master transmitter plus sensors or master transmitter plus iXT/MPX plus sensors) for max. three or max. nine sensors:
 - **Up to three** POA or CS2 sensors or Electronic Boxes Type EBM with sensors type CSM and DSM can be connected to the device Type **M3/G3** at the same time.
 - **Up to nine** sensors or Electronic Boxes Type EBM can be connected to the device Type **M9/G9** when using MPX/iXT devices. These can be used for 1...3 independent measurement places, provided that the transmitter is equipped with several measurement places per default.
- **Level 2 for different measurement methods or cross-correlation** (master transmitter plus 3 transmitters plus sensors or master transmitter plus 3 transmitters plus iXT/MPX plus sensors) for max. nine or max. 27 sensors:
 - Using the additional **Modbus coupling** device licence (see chap. “18.2 Add-On Function Licences”), it is possible to couple the NF750 type M9/G9 transmitter (with multi-measurement point functionality) directly with up to three **other NFx transmitters** (NF5, NF6, NF7 - without multi-measurement point functionality) instead of iXT/MPX.
This allows several measurement sections of a measurement to be operated with **different** measurement methods (transmit time, surface velocity radar, cross-correlation) and all measurement sections to be combined into a common overall measurement.
 - If **three** additional **NF750 transmitters** are connected for cross-correlation under the same basic conditions, as an alternative to the different measurement methods, and the sensors are connected via iXT/MPX, the number of flow velocity sensors that can be connected increases to **up to 27**.
- **Level 3 for cross-correlation** (master transmitter plus 3 transmitters plus 9 transmitters plus iXT/MPX plus sensors) for max. three or max. 81 sensors:
 - If 1x **NF750 type M9/G9** with **multi-measurement point functionality** plus

Modbus coupling device licence plus **3x NF750 type M9/G9** with **multi-measurement point functionality** and connection of the sensors via **iXT/MPX** are used in combination, a cross-correlation measurement place with **up to 81** flow velocity sensors can even be implemented.

➡ See also Chap. “25.5 Basic structure of multi-measurement places (via Modbus coupling)”.

20 Functional Principles

20.1 Flow Velocity Measurement

20.1.1 Cross Correlation



Note on the Ultrasound Reflection Principle

The flow velocity measurement method is based on the ultrasound reflection principle. Therefore, it is indispensable for the function of the system that particles (dirt particles, gas bubbles or similar) are present in the water. These particles reflect the ultrasonic signal emitted by the sensor.

The transducer, which is inclined in the direction of flow, works as a velocity sensor. For this purpose, a short ultrasonic signal beam is irradiated into the measurement medium at a defined angle. All particles in the measurement path (air, dirt particles, suspended particles) reflect parts of the ultrasonic signal. Depending on the size and shape of the particle, this produces a special ultrasonic reflection signal.

The multitude of reflected signals results in a reflection pattern (see Fig. 20-1). This pattern is received back by the transducer, converted into electrical signals and loaded into a digital signal processor (DSP) contained in the sensor.

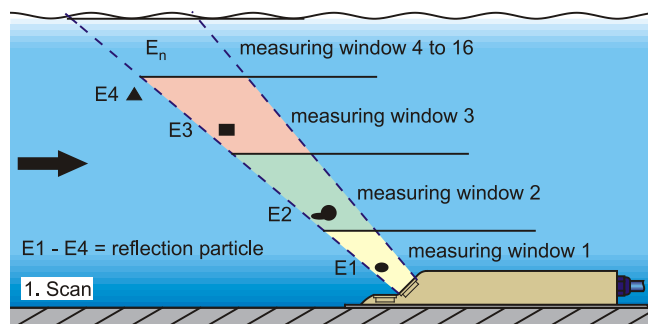

Fig. 20-1 Situation at first signal reception

After a defined time, a second ultrasonic pulse is irradiated into the medium. The newly received reflection signal is also loaded into the DSP.

Different flow velocities prevail at different flow heights (flow velocity profile).

The reflecting particles have thus moved on to different distances from the first measurement point, depending on their height. This creates a shifted image of the reflection pattern (see Fig. 20-2).

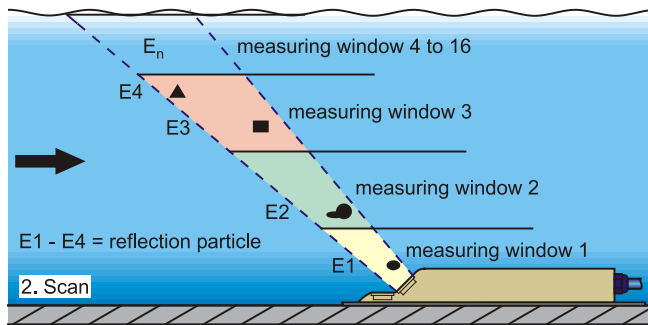

Fig. 20-2 Situation at second signal reception

The two reflection patterns are checked for their similarities in the DSP using cross-correlation methods. All signals that cannot be clearly identified (new particles, rotated particles) are discarded, leaving two shifted signal patterns that are similar to each other.

Up to 16 measurement windows are overlaid on these two images, depending on the previously performed height measurement. The time shift Δt of the pattern is determined in each measurement window (see Fig. 20-3).

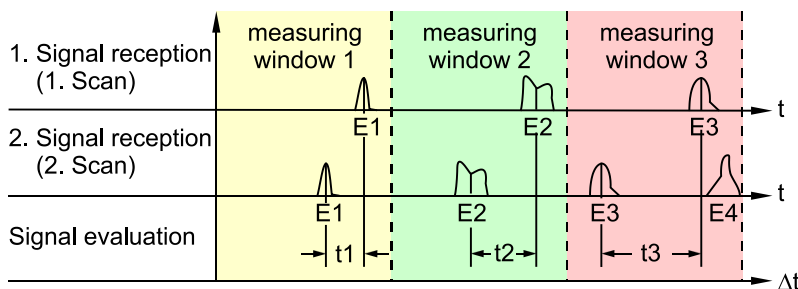

Fig. 20-3 Echo signal formation and evaluation

The flow velocity is determined in each measurement window on the basis of the transmission angle, the temporal distance between the two transmission signals and the difference in the signal pattern.

The mathematical stringing together of the individual calculated flow velocities results in the velocity profile of the acoustic path.

This measured velocity profile is shown directly in the display of the NivuFlow.

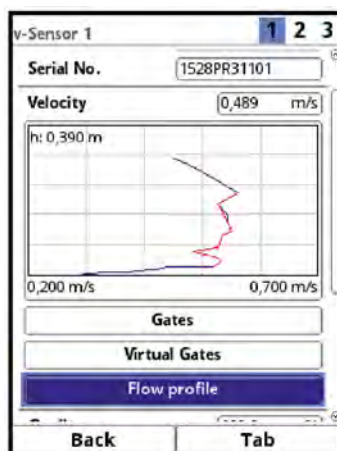

Fig. 20-4 Measured flow profile in the display

If the calming distance at the measuring point is sufficient, a three-dimensional flow distribution (see Fig. 20-5) can be calculated. This is based on the geometric data of the channel and the velocity distribution.

For asymmetrical flow profiles or structured profiles, the use of several flow velocity sensors is recommended. The positions of the sensors entered in the transmitter are thereby taken into account with their individual vertical V-profile in the 3D overall profile and also displayed.

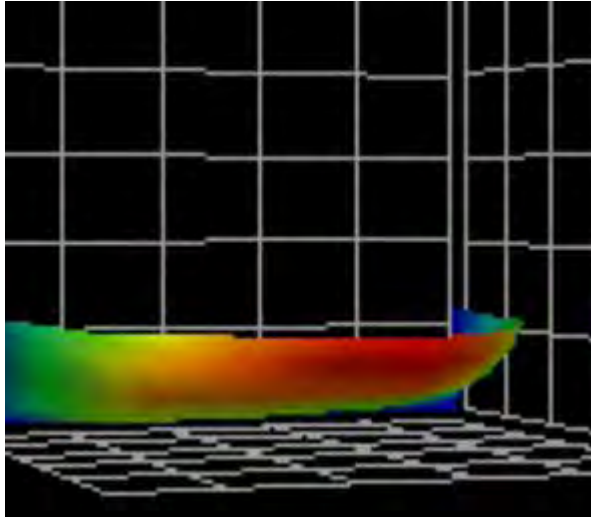

Fig. 20-5 Computed 3D velocity distribution

Based on the positions of the measured gate velocities and taking into account the channel shape and dimensions, the exact flow rate is calculated, displayed and output by means of scientifically determined hydraulic models stored in the device.

20.2 Level Measurement

20.2.1 External Level Sensor

Depending on the selected type of level measurement, an external 4...20 mA signal can be used for the level (e.g. using an i-Series sensor).

The 2-wire sensors powered by the NivuFlow (e.g. NivuBar Plus, i-Sensor) can be connected directly. Alternatively, a 4...20 mA signal coming from an external transmitter can be used (e.g. 4...20 mA from the NivuMaster).



i-Series Sensors

The i-Series sensors have pre-programmed measurement ranges. Observe the exact specifications in the instruction manual for i-Series sensors.

The i-Sensor can also be put into operation without a HART modem, provided it is connected to the HART input of the NF7 or to an iXT/MPX with a HART input.

Enter the max. possible measuring span of the sensor in the "Value at 20 mA" parameter. Depending on the mounting height of the sensor, a negative offset must also be set.

	i-3	i-6	i-10	i-15
Distance to sensor face in [m] at 4 mA (empty) 0 %	3.0	6.0	10.0	15.0
Distance to sensor face in [m] at 20 mA (full) 100 %	0.125	0.300	0.300	0.500
Max. possible measurement span (value at 20 mA) in [m]	2.875	5.7	9.7	14.5

Tab. 5 Measurement Span of i-Series Sensors

20.2.2 Water-Ultrasound

Depending on the selected sensor type, up to two different level measurements can be integrated in the water-ultrasonic combi sensor.

For water-ultrasonic measurement or hydrostatic level measurement, the sensor type includes:

- POA: one sound transducer
- CS2 wedge sensor: two differently sized transducers
- CSM: no water-ultrasonic measurement

For level measurement using water ultrasound, the horizontal transducer(s) work(s) according to the ultrasonic transit time method. The time between sending and receiving an impulse reflecting on the water surface is measured.

$$h_1 = \frac{1}{2} \cdot (c \cdot t_1)$$

- with:
 - h = Filling Level
 - c = Sound Transit Time
 - t_1 = Time between transmit and receive signal

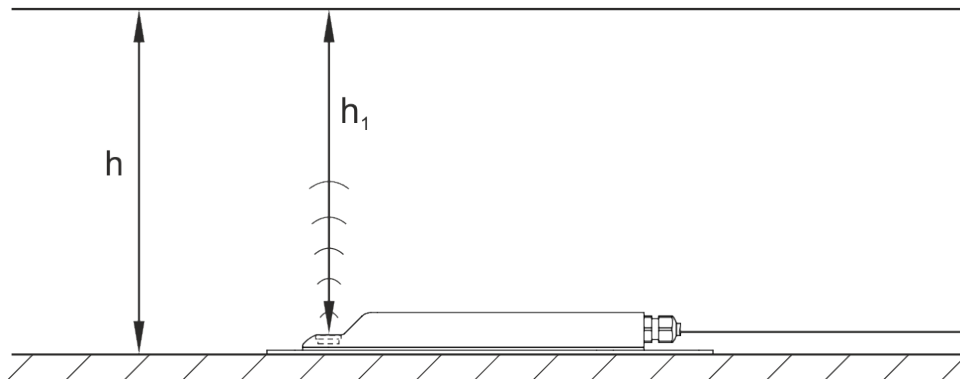

Fig. 20-6 Determined level

At a medium temperature of 20 °C, the sound transit time in water is 1480 m/s.

The temperature-dependent deviation is 0.23 % per Kelvin.

In order to realise a level measurement accurate to the millimetre, the medium temperature is therefore permanently determined. With the determined temperature, the sound propagation time is corrected for calculation.

The fixed height value is added to the determined value h_1 . This results in the total flow height h .

20.2.3 Pressure

POA and CS2 wedge sensors as well as the CSM-D sensor can optionally be equipped with an additional hydrostatic level measurement.

The piezoresistive pressure sensor works according to the relative pressure principle. The pressure of the stationary water column above the sensor is, depending on the density of the liquid, directly proportional to the filling level. Fluctuations in atmospheric air pressure are compensated for using a little air tube. This air tube is integrated in the sensor cable. The pressure sensor makes it possible to determine the flow height even if the sensor is installed off-centre (to the canal bottom).

The pressure sensor is calibrated during commissioning by entering a manually determined reference value. The height due to sensor mounting is also added.

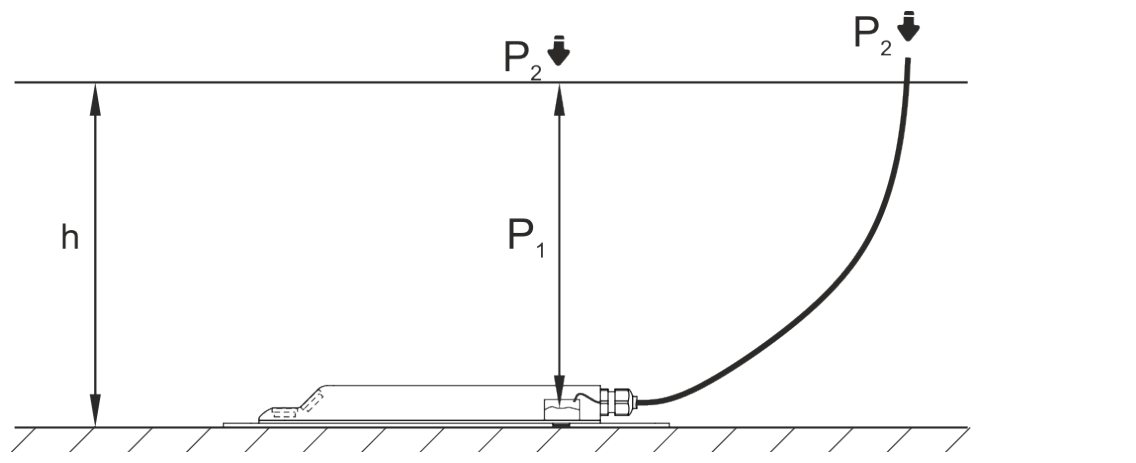

Fig. 20-7 Determined level

Installation and Connection

21 General Mounting Instructions

During installation, observe the following instructions on "Electrostatic Discharge (ESD)" and "Installation Location".

- 🔄 It is essential to follow applicable legal or company guidelines.

Improper handling may lead to personal injuries and/or equipment damage!

21.1 Avoiding electrostatic discharge (ESD)



ESD Risks

Maintenance procedures that do not require power to the unit must only be carried out after disconnection from the mains to minimise hazards and ESD risks.

Disconnect the NivuFlow from the mains.

The sensitive electronic components inside the unit can be damaged by static electricity. NIVUS GmbH recommend the following steps to prevent damage to the device due to electrostatic discharge:

- 🔄 Before touching electronic components of the appliance, discharge any static electricity from the body.
- 🔄 Avoid unnecessary movements to minimise the building-up of static charges.

21.2 Installation/Mounting Variants

The transmitter is available in two different installation variants:

- E0 - for direct DIN rail mounting in control cabinets or similar enclosures
- E1 - specially designed DIN rail enclosure without cover strips, with extended DIN rail fastening
 - Installation in NIVUS field enclosure *ZUB0 NFW0* or *ZUB0 NFW0 IP68*
 - Additional installation of an Ex Separation Module iXT within the field enclosure possible



Pre-mounted assembly when ordered at the same time

If NivuFlow 750/700 (in installation variant E1) is ordered together with the Ex Separation Module and field enclosure at the same time, the units are delivered pre-assembled and wired to each other via a bus cable.

CAUTION



NivuFlow 750/700 installation variant E0 not suitable for installation in NIVUS field enclosure

*Subsequent installation of a transmitter with installation variant E0 in a NIVUS field enclosure is not possible without **conversion** to installation variant E1. The conversion and the change of connection can be carried out by NIVUS.*

Subsequent Installation in NIVUS Field Enclosure

If a converted transmitter installation variant E0 (then corresponds to E1) and an iXT Ex Separation Module are installed in a NIVUS field enclosure, the connection between the transmitter and iXT must be made in accordance with Fig. 21-1 or Fig. 21-2.

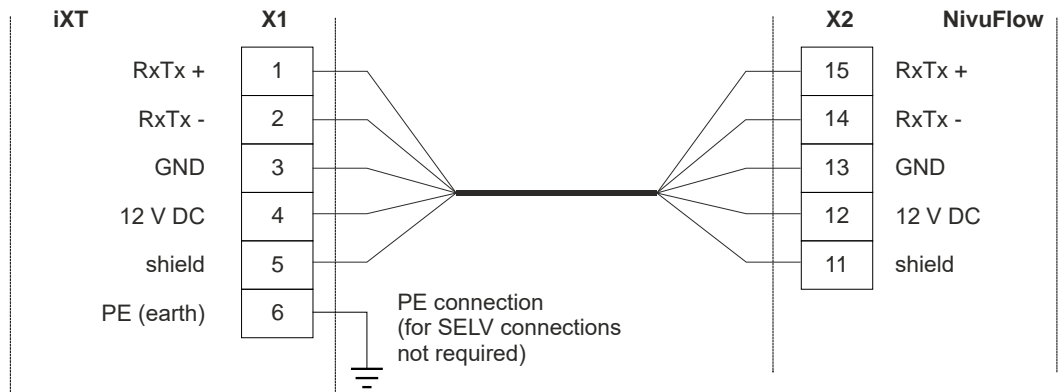

Fig. 21-1 Connection NF750/700 Type S1/G1/SR/GR

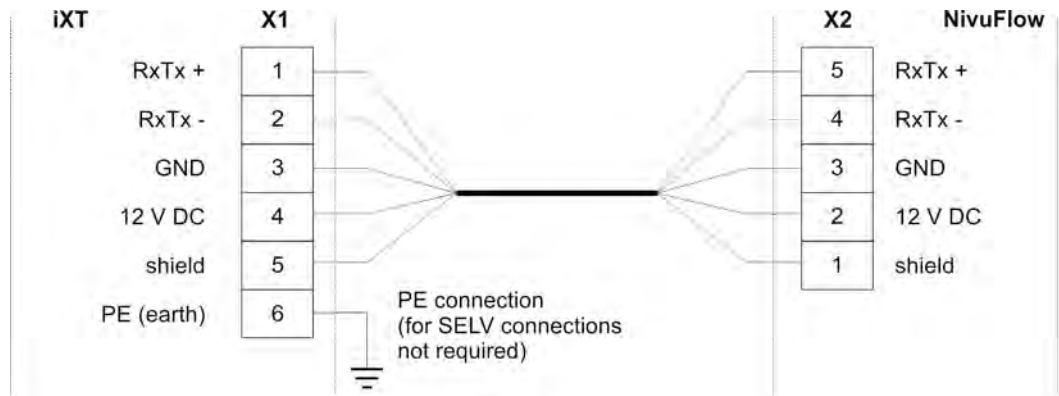

Fig. 21-2 Connection NF750 Type M3/G3

When installing the transmitter and the iXT in the field enclosure, ensure the correct installation position. This is given by the separation on the inside of the enclosure cover. The display of the transmitter must be centred in the viewing opening of the enclosure cover. Minor corrections can be made by moving the unit on the DIN rail. **For reasons of explosion protection, the connection cable (Fig. 21-3 Pos. 2) between iXT (Fig. 21-3 Pos. 4) and transmitter (Fig. 21-3 Pos. 3) must be laid above the separation (Fig. 21-3 Pos. 1) in the cover of the field enclosure (Fig. 21-3 Pos. 5).**

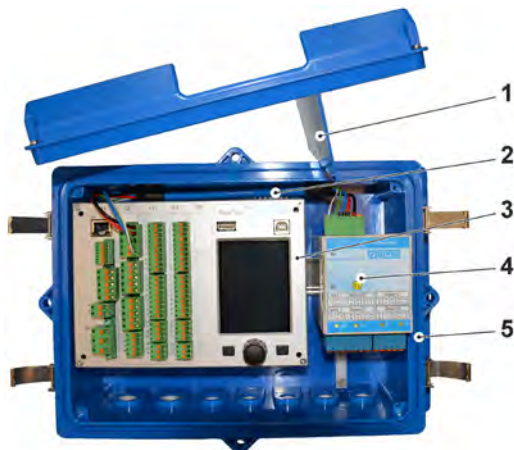

Fig. 21-3 Cable Routing in the Field Enclosure

21.3 Selecting the Mounting Place

The NivuFlow with DIN rail mounting is designed for installation in control cabinets, switching boxes and mounting frames.

- Ensure sufficient ventilation at the mounting place. For example by means of fans or air vents.
- Make sure that access to any disconnecting devices (mains switches) is not impeded by the installation.

The transmitter can also be installed in on-site enclosures. Due to its protection class, however, the transmitter is not suitable for direct unprotected mounting on site. Use the optionally available field housing from NIVUS for this purpose.

The following precautions must be taken at the mounting place for safe installation:

- Protect the transmitter from direct sunlight. If necessary install a sunshade.
- Do not install the transmitter in the vicinity of strong electromagnetic fields (frequency converters, high-voltage lines, etc.).
- Observe the permissible ambient temperature (see Chap. "17 Specifications").
- Do not expose the transmitter to strong vibrations or mechanical shocks.

When selecting the installation location, avoid the following conditions under all circumstances:

- Corrosive chemicals or gases
- Radioactive radiation
- Installation close to footpaths or travel ways

21.4 Fastening the transmitter to a DIN rail in the control cabinet



Gather the required materials beforehand

*Mounting material and tools are **not** included in the scope of delivery.*

- For mounting use a DIN rail Type TS35 according to EN50022 with a minimum length of 140 mm.
 1. Fasten the DIN rail horizontally in the enclosure/switch cabinet provided using at least two screws.
 2. Hook the transmitter into the DIN rail from below. The device locks into place by pressing lightly in the direction of the DIN rail.

The electrical installation and connection of the sensors can then be carried out.

21.5 Fastening the field enclosure and preparations for electrical installation



Gather the required materials beforehand

*The fastening material is **not** part of the delivery, but must be individually defined and compiled, depending on the installation location.*

After selecting a suitable installation location, the NIVUS field enclosure can be permanently mounted. The basic condition for the fastening is that it is secure, durable and stable.

Required Materials and Aids

- 6x fastening screw M5, M6 or other screws suitable for diameter 6.5 mm for fastening to the surface (selection of screw type and screw length depending on surface)

material/condition)

- Possibly 6x dowels (depending on the surface material/condition and the fastening screws used)

Preparatory Work

➡ Procedure:

1. Select fastening screws (screw type/length) and accessories, taking into account:
 - the condition and load-bearing capacity of the surface at the installation location (wood, metal, concrete, masonry, etc.)
 - the need for dowels and, if necessary, other aids

Tip:

When determining the length of the screws, be sure to include the material thickness of the two fastening lugs (approx. 17 mm).

2. If necessary, drill dowel holes at the installation location and insert dowels.

Fastening the Field Enclosure

➡ Procedure:

1. Fasten the field enclosure (Fig. 21-4 Pos. 3) with the six pre-selected fastening screws through the through holes with diameter 6.5 mm (Fig. 21-4 Pos. 6) to the two side lugs.

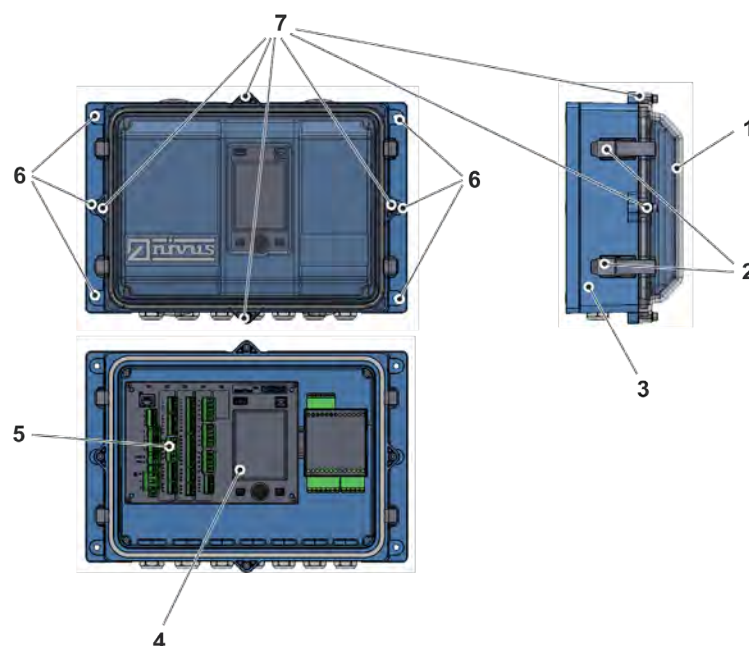

Fig. 21-4 Fastening the Field Enclosure

2. If present, remove the transport protection foil from the transparent enclosure cover (Fig. 21-4 Pos. 1).

Tip:

The protective foil will harden due to UV radiation and may not be able to be removed without residue later. The alteration of the protective foil can lead to severe optical impairments.

New transparent enclosure covers can be purchased from NIVUS and easily replaced by the user.

3. If available, mount the weather protection roof.

Preparing the field enclosure for electrical installation

➡ Procedure:

1. To remove the transparent enclosure lid (Fig. 21-4 Pos. 1) from
 - enclosure *ZUB0 NFW0* (with protection class IP67):
Open the four clamp locks on each side (Fig. 21-4 Pos. 2) and remove the enclosure cover.
 - Enclosure *ZUB0 NFW0 IP68* (with protection class IP68):
Remove the four cylinder head screws M4x25 (Fig. 21-4 Pos. 7) with the corresponding washers; open the four clamp locks (Fig. 21-4 Pos. 2) and remove the enclosure cover.
2. To remove the inner blue cover, unscrew the four round-head screws M3.5x25 in the corners and remove the cover. Now the transmitter, the display (Fig. 21-4 Pos. 4), the connection terminals (Fig. 21-4 Pos. 5) and the iXT are freely accessible.
3. Reassembly after connection is done in reverse order. Make absolutely sure that
 - the gaskets are free of dirt and have no damage and
 - the screws are all tightened firmly
 Otherwise, protection class IP67/IP68 can **no longer be guaranteed**.

CAUTION



Do not install the overvoltage protection together with the transmitter in the ZUB0 NFWx field enclosure

Details see Chap. "26 Overvoltage Protection Measures".

22 Electrical Installation

DANGER



Danger by electric voltage

Disconnect the device from mains power.

When working on the electrical connections, there is a risk of electric shock. Necessarily observe the electrical data given on the nameplate.

Disregarding may lead to personal injury.



Note

Observe the national installation instructions.

➡ Make sure that the following requirements are met:

1. Please note that installation may only be carried out by qualified personnel.
2. For electric installation follow the legal requirements of the respective country (in Germany e.g. VDE 0100).
3. Observe further (country-specific) statutory standards, regulations and technical rulings.
4. For installation in wet environments or in areas where there is a risk of flooding, additional protection, e.g. by means of a residual current device (RCD), may be required.
5. Check whether the power supply of the units must be integrated into the emergency stop concept of the plant; also with regard to explosion protection.

6. Before feeding the rated voltage the installation of transmitters and sensors must be completed. Verify whether the installation is correct.



The connection of the sensors is described from Page 53, the connection of the power supply on Page 46.

22.1 Connection to the spring-cage terminal blocks

All NivuFlow transmitters are equipped with pluggable spring-loaded terminals. The use of the pluggable spring-loaded terminal blocks allows easy pre-installation of the transmitter. This allows individual sensors, input and output signals, etc. to be checked and, if necessary, the transmitter to be replaced quickly.

The spring-loaded terminal blocks are suitable for the connection of single and multi-wire copper cables and are vibration-resistant.

- ➡ To open the contacts on the spring-loaded terminal blocks, press the front orange elements with moderate pressure using a slotted screwdriver.

Pluggable and screwable spring-loaded terminal blocks are used to connect the power supply. Use a slotted screwdriver with a blade width of 3.0...3.5 mm to connect the power supply.



Important Notice

The spring-loaded terminal blocks may only be plugged and unplugged in a de-energised and voltage-free state.

DANGER



Danger by electric voltage

Multi-core cables (stranded wires) in the area of the AC power supply as well as the relay connections must be fitted with wire end ferrules with an insulated protective collar (plastic sleeve) in order to avoid danger from individual protruding cores.

Disregarding may lead to personal injury.

Spring-cage terminal block	Power Supply	Bus/Network	Clamps O/I etc.	Air-Ultrasonic Active Sensor OCL
Cable cross-section (rigid) in [mm ²]	0.2...2.5	0.2...0.5	0.14...1.5	0.2...2.5
Cable cross-section (flexible) in [mm ²]	DC only: 0.2...2.5	0.2...0.5	0.14...1.5	0.2...2.5
Cable cross-section (flexible) with wire ferrule blank in [mm ²]	DC only: 0.25...2.5	0.25...0.5	0.25...1.5	0.25...2.5
Cable cross-section (flexible) with wire end ferrule with insulated protective collar in [mm ²]	0.25...2.5	Not defined	0.25...0.5	0.25...2.5

Tab. 6 Cable cross-sections

The transmitter **NivuFlow 750** is available in eight different **versions** (see also Tab. 4 on page 28):

- Type S1 - Standard version for one flow velocity sensor, one level sensor and the option of an external level sensor.
- Type G1 - Standard version for one flow velocity sensor, one level sensor and the option of an external level sensor. With integrated wireless modem.
- Type SR - Standard version with additional controller function.
- Type GR - Standard version with additional controller function and integrated wireless modem.
- Type M3 - Extended connection options for up to three flow velocity sensors.
- Type G3 - Extended connection options for up to three flow velocity sensors. With integrated wireless modem.
- Type M9 - Option to connect up to nine sensors via iXT or MPX. Suitable for very wide channels or for up to three different measurement places in close proximity.
- Type G9 - Option to connect up to nine sensors via iXT or MPX. Suitable for very wide channels or for up to three different measurement places in close proximity. With integrated wireless modem.

All eight variants have identical terminal designations. These blocks are functionally assigned to the different connection areas. The versions SR/GR/M3/G3/M9/G9 are equipped with additional terminal blocks.

The transmitter **NivuFlow 700** is available in two versions:

- Type S1 - Standard version for one flow velocity sensor, mounted in full channels or pipes.
- Type G1 - Standard version for one flow velocity sensor, mounted in full channels or pipes. With integrated wireless modem.

22.2 Terminal Wiring Diagrams

DANGER



Risk of Electric Shock

Never remove the spring-loaded terminal block from the plug-in board X1 (connections 15...17).

This spring-loaded terminal block is used to connect the protective earth conductor and the AC power supply and is an integral part of the device. The device may only be operated with the spring-loaded terminal block screwed on.

Disregarding may lead to personal injury.

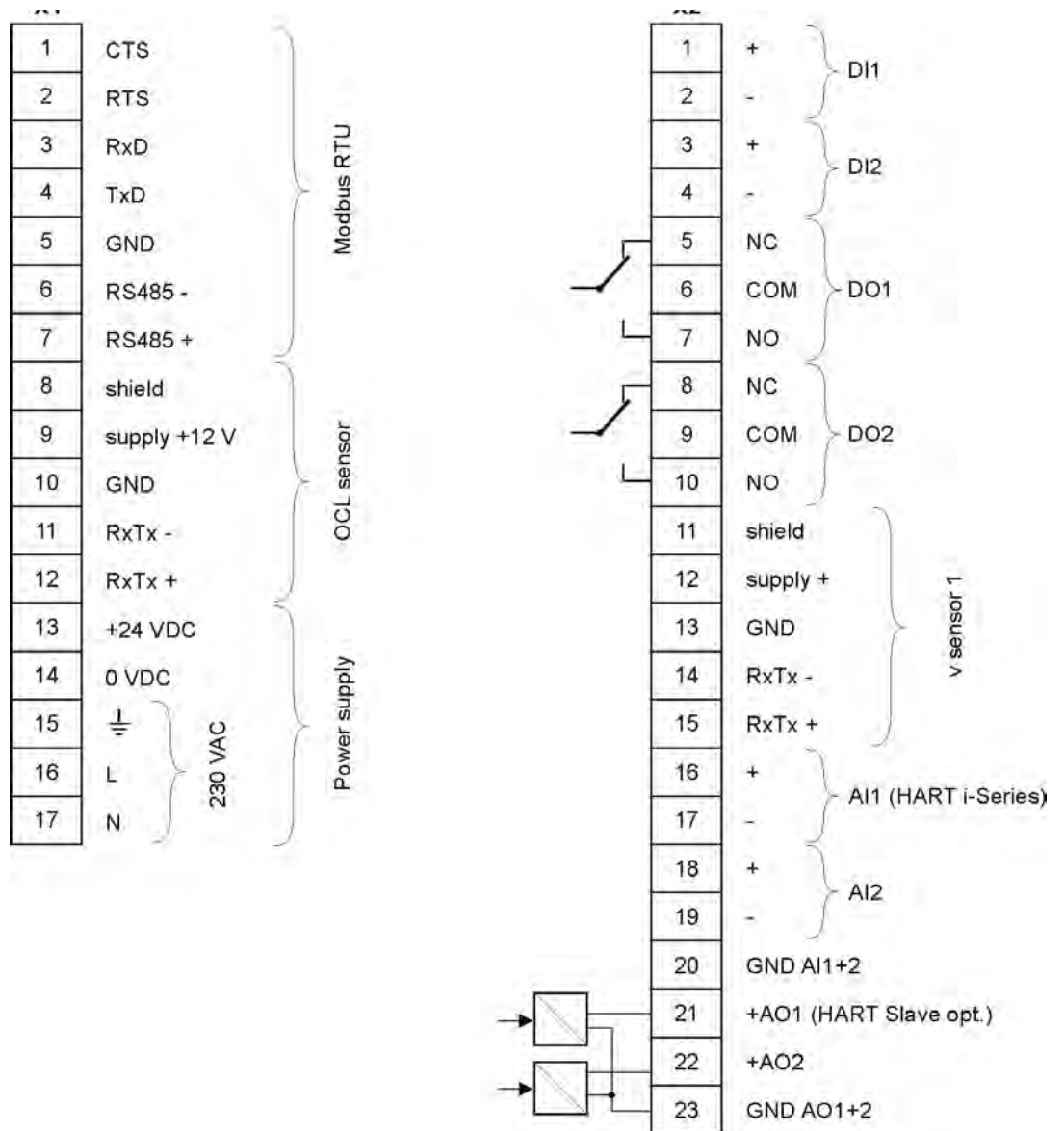

Fig. 22-1 Wiring diagram NivuFlow 750/700 Type S1/G1

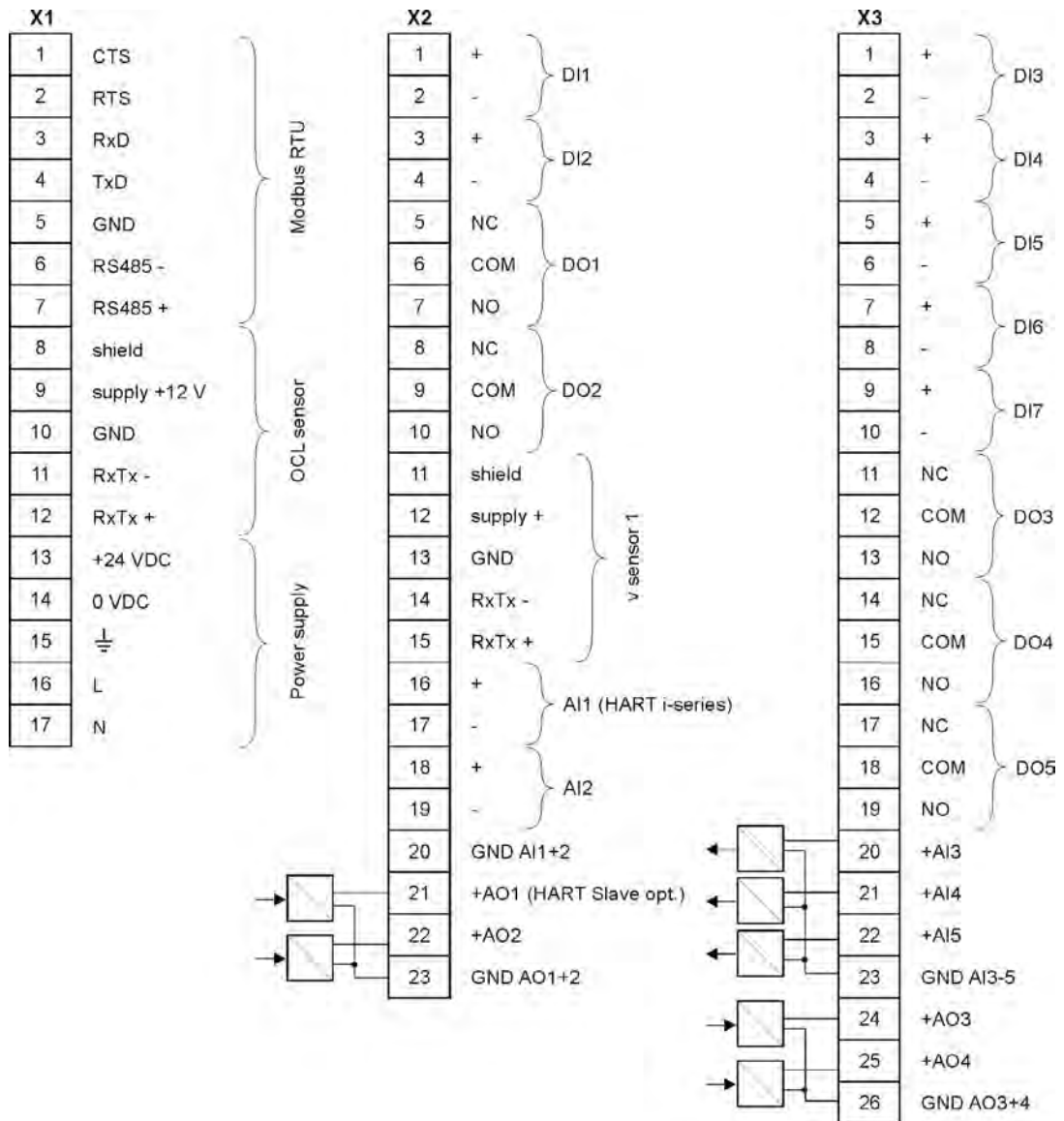

Fig. 22-2 Wiring diagram NivuFlow 750 Type SR/GR

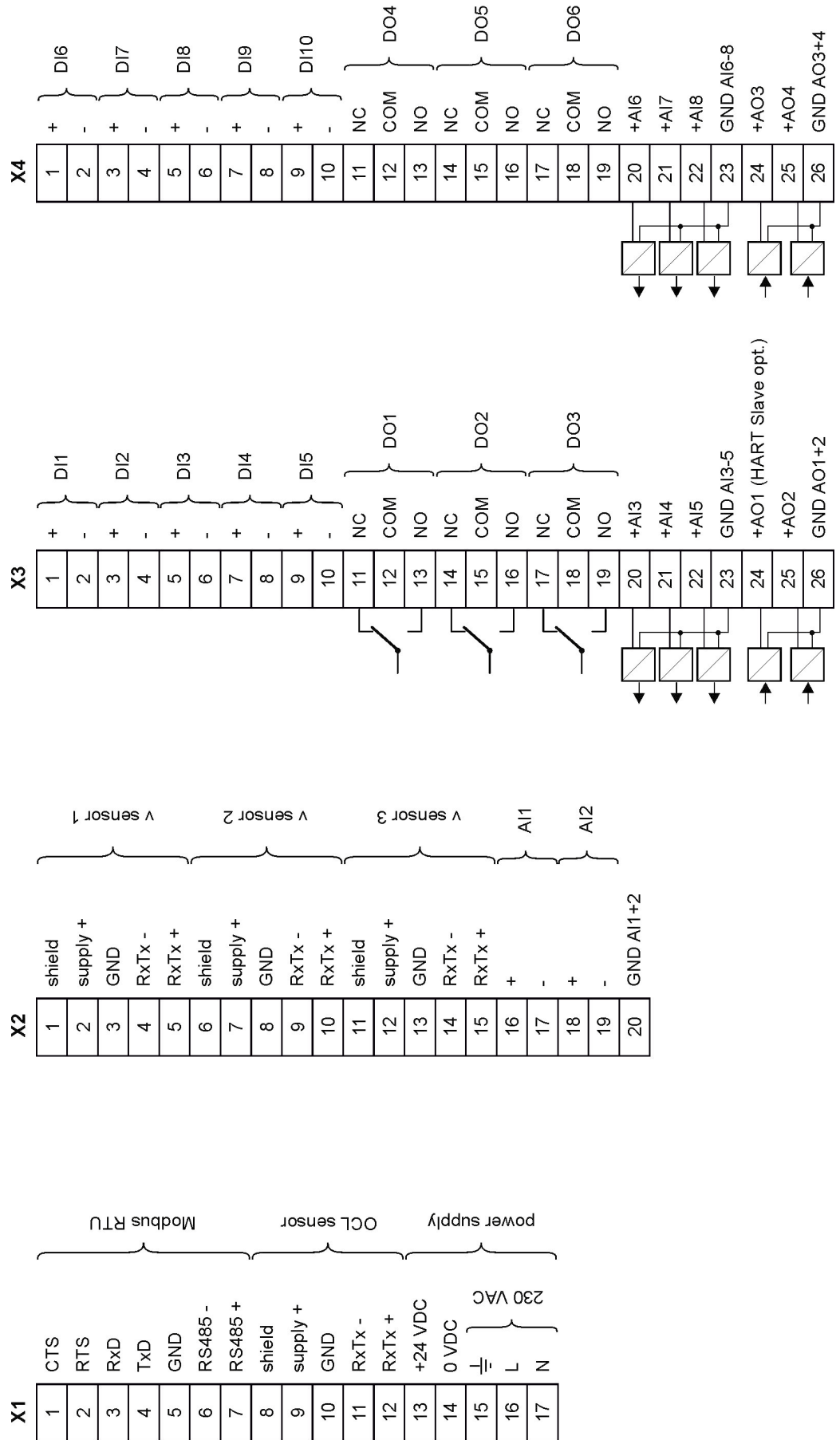

Fig. 22-3 Wiring diagram NivuFlow 750 Type M3/G3/M9/G9

22.3 Connecting the Power Supply

Depending on the type, the NivuFlow transmitter can be operated with 100...240 V AC (-15 / +10 %) or with 10...35 V DC.

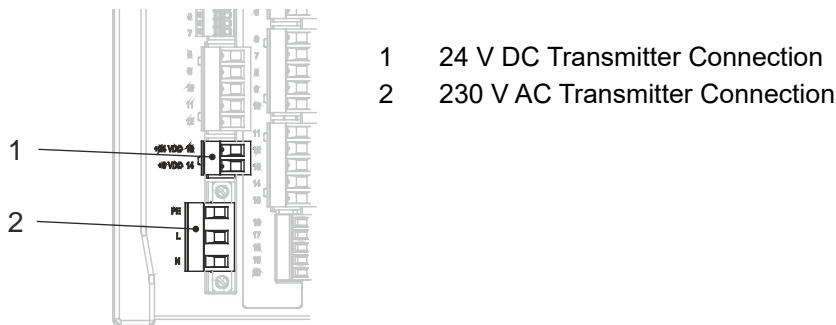

Fig. 22-4 Power Supply Wiring Diagram NivuFlow

DANGER



Risk of Electric Shock

Never remove the spring-loaded terminal block from the plug-in board X1 (connections 15...17).

This spring-loaded terminal block is used to connect the protective earth conductor and the AC power supply and is an integral part of the device. The device may only be operated with the spring-loaded terminal block screwed on.

Disregarding may lead to personal injury.



Use of Alternating Current - Direct Current

A 24 V **DC** unit must **not** be operated with **alternating current** (AC). Conversely, it is also **not possible** to operate a 230 V **AC** unit with 24 V **direct current** (DC).

22.3.1 DC Power Supply

The DC version can be operated directly on the 24 V DC network of a control cabinet.

Prerequisites

- Available input voltage at the input terminals:
 - With maximum load (20 W) at least 10 V
- Terminal voltage:
 - In no-load operation maximum 35 V

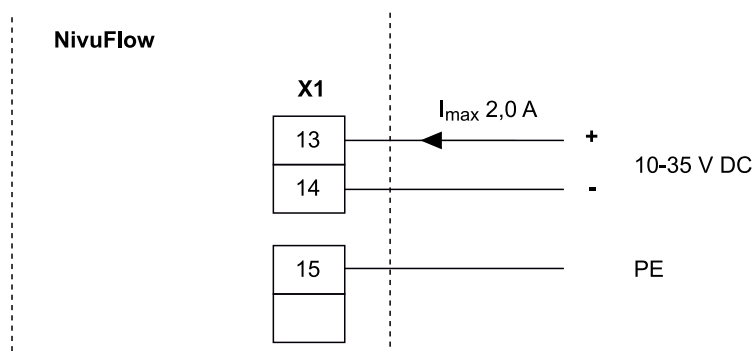

Fig. 22-5 Connection Power Supply DC Version

22.3.2 Power Supply AC

DANGER



Danger by electric voltage

The device may only be operated when the terminal blocks are screwed on tightly over the screw flange.

The spring-loaded terminal block X1 (terminals 15...17), for connecting the protective earth conductor and the AC power supply, is an integral part of the unit and not a plug connection. Disregarding may lead to personal injury.

DANGER



Danger by electric voltage

The power supply of the transmitter must be separately protected with a 6 A slow-blow fuse and disconnected independently of other circuit parts, e.g. by means of a circuit breaker with characteristic B. The disconnecting device must be marked in a suitable manner.

Disregarding may lead to personal injury.

The AC version of the NivuFlow can be operated directly from the low-voltage mains.



For AC supply requirements, see Chap. "17 Specifications".

Prerequisite

- Cross-section of the mains cables:
 - Minimum 0.75 mm²
 - According to IEC 227 or IEC 245

The AC version of the NivuFlow provides an auxiliary voltage of 24 V with a maximum load capacity of 80 mA at the terminals of the DC connection. This auxiliary voltage can be used, for example, in devices with integrated controller function for the necessary connection of the contacts of the slider end positions or the torque switch to the digital inputs of the NivuFlow.

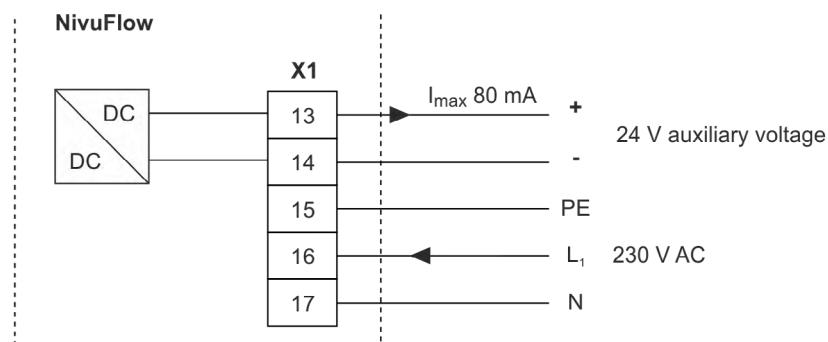

Fig. 22-6 Connection Power Supply AC Version

22.4 Relay

Falling below the specified minimum switching current reduces the reliability of the switching contact.



It is essential to observe the specified connection and switching data in Chapter “17 Specifications”.

Relay 2 is designed as a bistable relay (i.e. it remains in the last activated position when de-energised) and is therefore not suitable as an error message relay. Only for Type S1/G1/SR/GR.

DANGER



Danger by electric voltage – Contact protection measures

For relay voltages >150 V, the test pin connection of the relay terminal blocks does not guarantee touch protection according to the requirements of EN61010-1:2010.

Ensure additional contact protection measures in accordance with the applicable regulations and laws. For example: Open control cabinet/field enclosure only with tool or key, residual current circuit breaker or similar.

Disregarding may lead to personal injury.

DANGER



Danger by electric voltage - Protect relay contacts

If voltages in the low-voltage range (e.g. AC mains voltages) are switched via the relay contacts of the unit, these must be protected with 6 A slow-blow fuse. These contacts must be able to be switched off independently of other circuit parts.

A suitable protective earth connection must also be ensured for DC units to prevent the occurrence of dangerous voltages or currents.

Disregarding may lead to personal injury.

23 Installation and Connection of Sensors

The exact description for mounting the individual sensor types is described in the respective installation instructions.



Note

During assembly work, ensure that all work safety regulations are observed.

23.1 Sensor Installation Principles

The placement of the sensors is decisive for reliability and accuracy of the measurement results. Therefore, care must be taken to ensure good hydraulic conditions and a sufficient calming section at the installation site. The sensor types and their mounting must be determined individually, depending on the measuring point.



The conditions for selecting a calming section and mounting the sensors are described in the respective installation instructions.

23.2 Cables and Cable Lengths for Sensor Connection



Cable designations may vary from country to country

The cable designations used may differ outside Germany. If you are unsure about the cable design (based on cable data sheets), ask NIVUS whether the respective cables are suitable.

Between Sensor and Transmitter (Direct Connection Non-Ex)

If possible, use the cable specified by NIVUS for the total distance between the NIVUS sensors and the NivuFlow transmitter:

- LiYC11Y 2x1.5 mm² + 1x2x0.34 mm² + PA

PA means the pressure compensation hose in the sensor cable.

The signal cable is not intended for permanent direct burial. If the signal cable is to be laid in soil, concrete or similar, the signal cable must be laid in suitable protective pipes or protective hoses with a sufficiently dimensioned inner diameter.

Between Sensor and iXT

Maximum cable lengths between sensors and the iXT when using the NIVUS standard cable LiYC11Y 2x1.5 mm² + 1x2x0.34 mm² + PA:

- 150 m
- When using Overvoltage Protection Elements
 - One-sided: 135 metres
 - Two-sided: 120 metres

➡ See also Chapter “26 Overvoltage Protection Measures”.

PA means the pressure compensation hose in the sensor cable.

Between iXT/MPX and Transmitter (Standard Cable)

Maximum cable lengths between transmitter and iXT/MPX when using the NIVUS standard cable LiYC11Y 2x1.5 mm² + 1x2x0.34 mm² + PA:

- iXT - 100 meter
MPX - 100 meter
- When using Overvoltage Protection Elements:
 - No Change

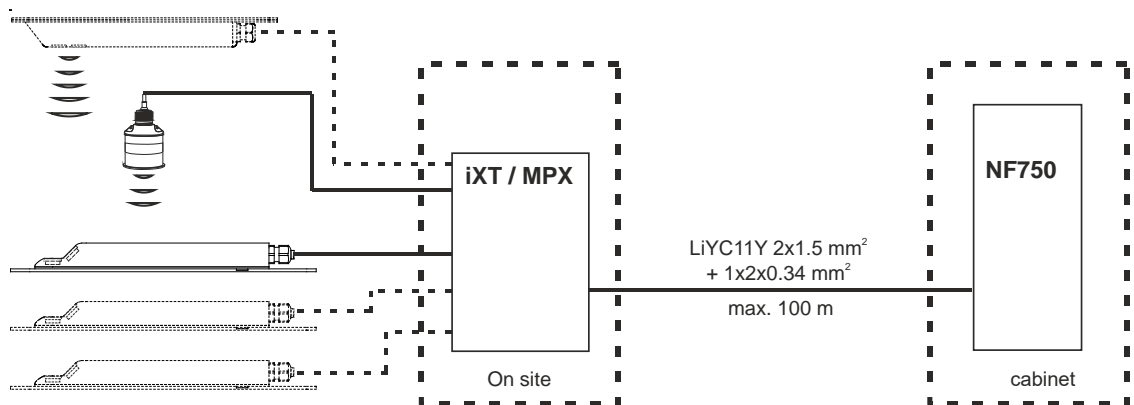

Fig. 23-1 Connection iXT/MPX to NivuFlow via standard cable

Between iXT/MPX and Transmitter (Telephone Cable)

Maximum cable length between iXT/MPX and transmitter when using a telephone cable type A2Y(L)2Y 10x2x0.8 (or similar):

- iXT - 300 meter
- MPX - 300 meter

For this purpose, nine wires each are combined for power supply and derivation (GND). One pair of wires is used for RS485 communication.

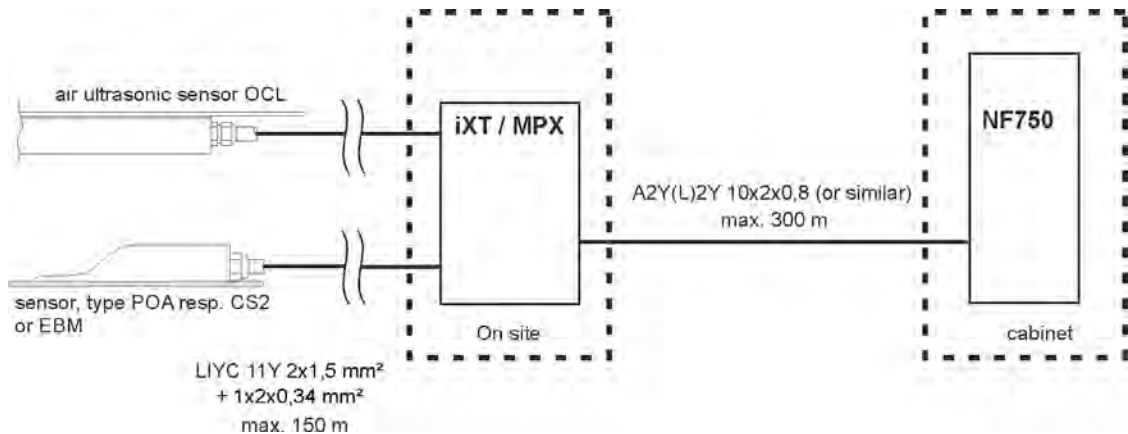

Fig. 23-2 Connection iXT/MPX to NivuFlow via telephone cable

23.3 Connection of iXT and MPX

Ex Separation Module iXT

The iXT serves as an Ex separation module for zone 1 between the sensors (Type POA, CS2, Electronic Box EBM, OCL Air Ultrasonic sensor and the NivuBar Plus series) and the transmitter NivuFlow.

The sensors must have approvals for Ex zones 1 or 0:

- Zone 1:
POA, CS2, Electronic Box EBM, OCL Air Ultrasonic sensor and the NivuBar Plus series
- Zone 0:
i-Sensor



Note on the i-Sensor

The i-Sensor **Zone 1** is encapsulated and is connected **directly** to the NivuFlow, not to the iXT.

The i-Sensor **Zone 0** is intrinsically safe and may **only** be connected to the Ex isolating module iXT.

The **fuse** at the cable end of the Ex zone 1 sensor is Ex-relevant and must **not** be removed.



Ex Approval and EU Type Examination Certificate

The Ex approval is only valid in conjunction with the corresponding marking on the nameplate of the iXT enclosure.

The Ex-version of the iXT is matched to the NIVUS sensors regarding the assessment of intrinsically safe electrical systems according to EN 60079-25.

The technical data required here for the Ex version of the sensors can be found in the EU type examination certificate TÜV 03 ATEX 2262 or TÜV 12 ATEX 087812.

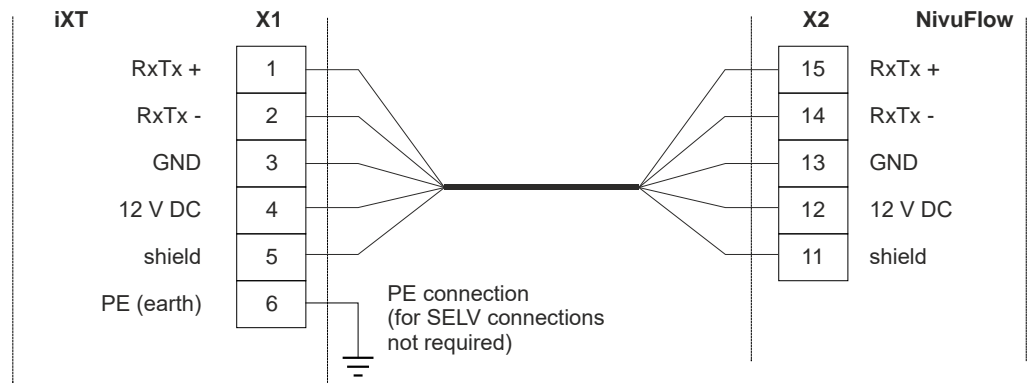

Fig. 23-3 iXT at NF750/700 Type S1/G1/SR/GR

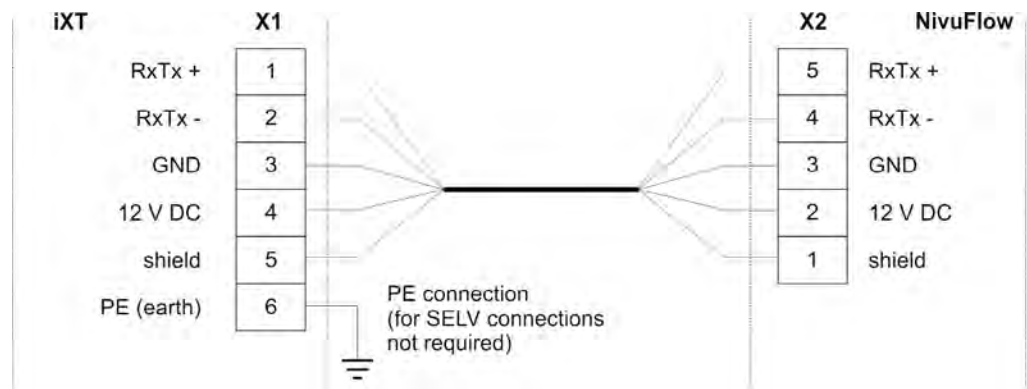

Fig. 23-4 iXT at NF750 Type M3/G3 or first iXT at NF750 Type M9/G9

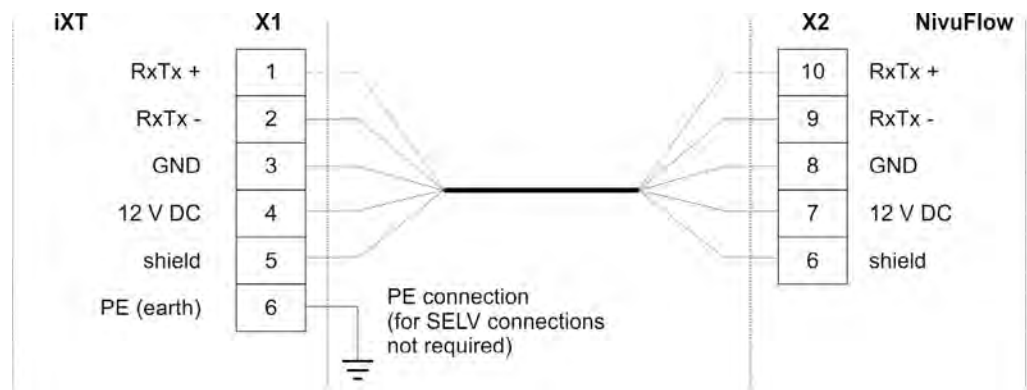

Fig. 23-5 Second iXT at NF750 Type M9/G9

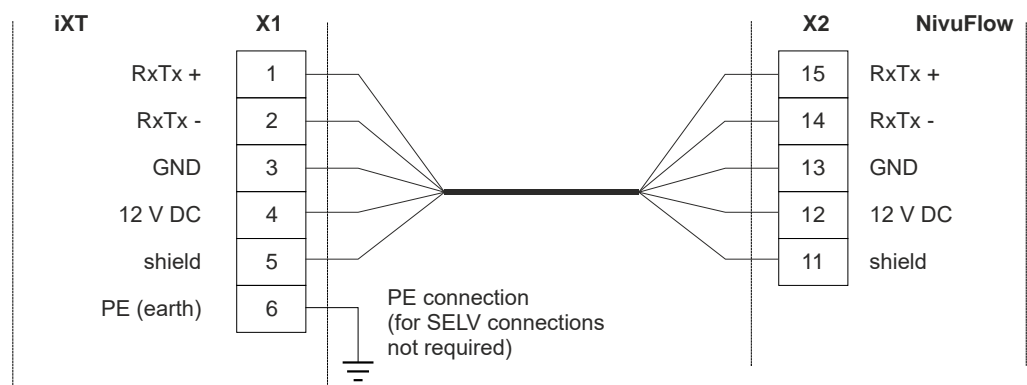

Fig. 23-6 Third iXT at NF750 Type M9/G9



For detailed information on the iXT, connecting the various sensors to the iXT, overvoltage measures, etc., see "Technical Description for the iXT0 Ex Separation Module".

Multiplexer MPX

The MPX multiplexer is an intelligent electronic module between one or more flow velocity and level sensors on site or close to the sensor. It brings together all sensor signals and transmits them safely to the NivuFlow transmitter using a single signal cable.

In combination with an auxiliary relay and an external power supply on site, it serves as a line driver. With a suitable cable, distances of up to 1000 metres are possible between MPX and NivuFlow.

The same sensors can be connected to the MPX as to the iXT.

Ex approvals are not required here.

In addition, a 4...20 mA level signal from an external transmitter can be applied.

When using a NivuFlow 750 type **M9/G9** transmitter and **several MPXs, up to nine flow velocity sensors** can be connected simultaneously and **up to three measurement places** can be parameterised (if the transmitter is equipped with this functionality, see also Tab. 4 on page 28).

When using a NivuFlow 750 type **M9/G9** transmitter with multiple measurement place capability and the device licence for **Modbus coupling** as a master transmitter and the coupling of **three further NF750 type M9/G9** transmitters (without multiple measurement place capability), the number of **flow velocity sensors** that can be connected can be **increased to 27**.

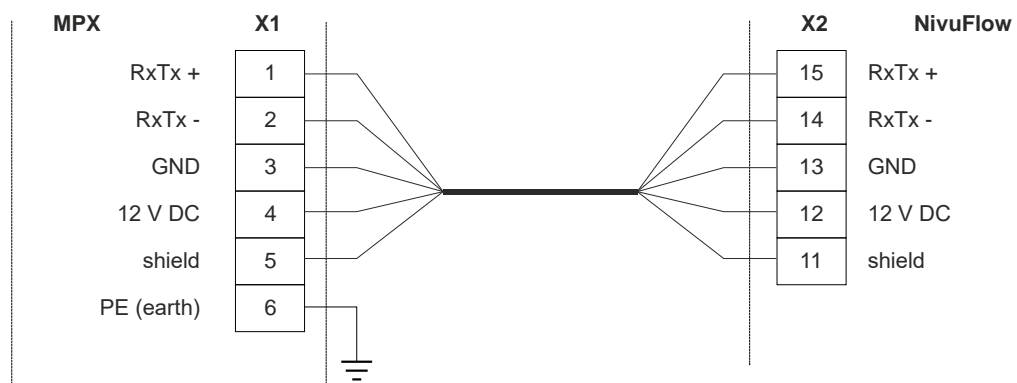

Fig. 23-7 MPX at NF750/700 Type S1/G1/SR/GR

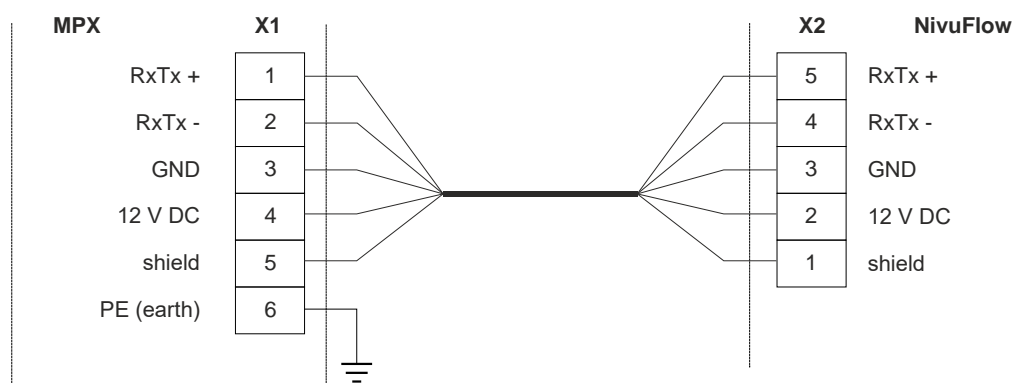

Fig. 23-8 First MPX at NF750 Type M3/G3/M9/G9

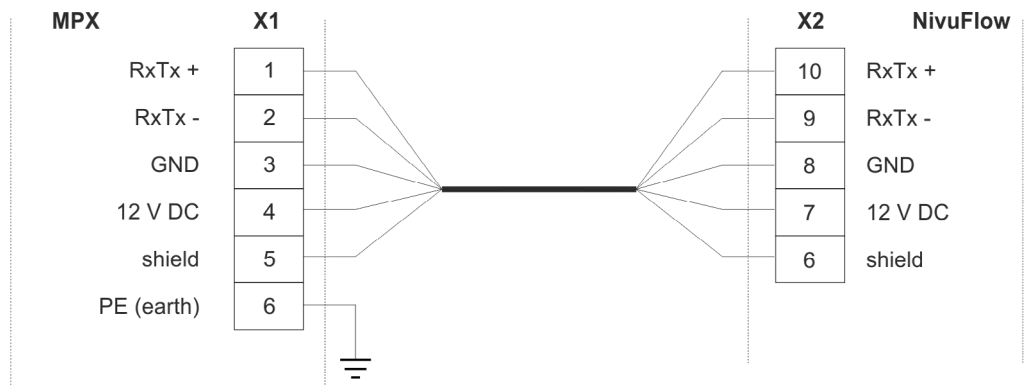

Fig. 23-9 Second MPX at NF750 Type M9/G9

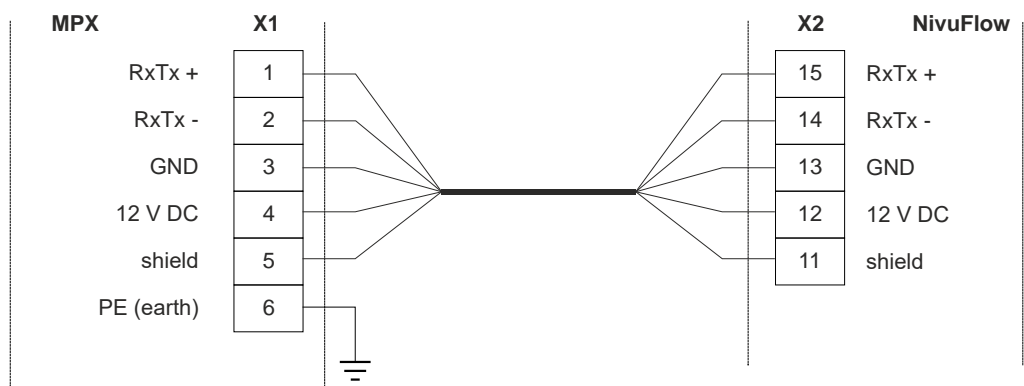

Fig. 23-10 Third MPX at NF750 Type M9/G9



For detailed information on the MPX, connecting the various sensors to the MPX, overvoltage measures, etc., see "Technical Description for the MPX Multiplexer".

23.4 Connecting Sensors to NivuFlow

The connected sensors are used to

- determine the flow velocity:
 - via the connected flow velocity sensors
- determine/define the level:
 - via the connected flow velocity or combi sensors
 - Using the Modbus
 - Using the definition of a fixed value

23.4.1 Connection of Flow Velocity Sensors

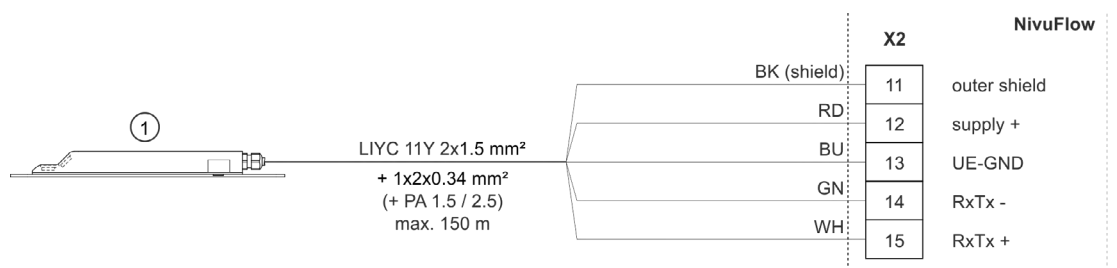

1 Connectable flow velocity sensors (POA-Vx00/VxH1/VxD0, CS2-Vx00/VxH1/VxD0/VxU1,

CSM/CSM-D/DSM via Electronic Box EBM)

Fig. 23-11 Connection flow velocity sensor to NF750/700 Type S1/G1/SR/GR

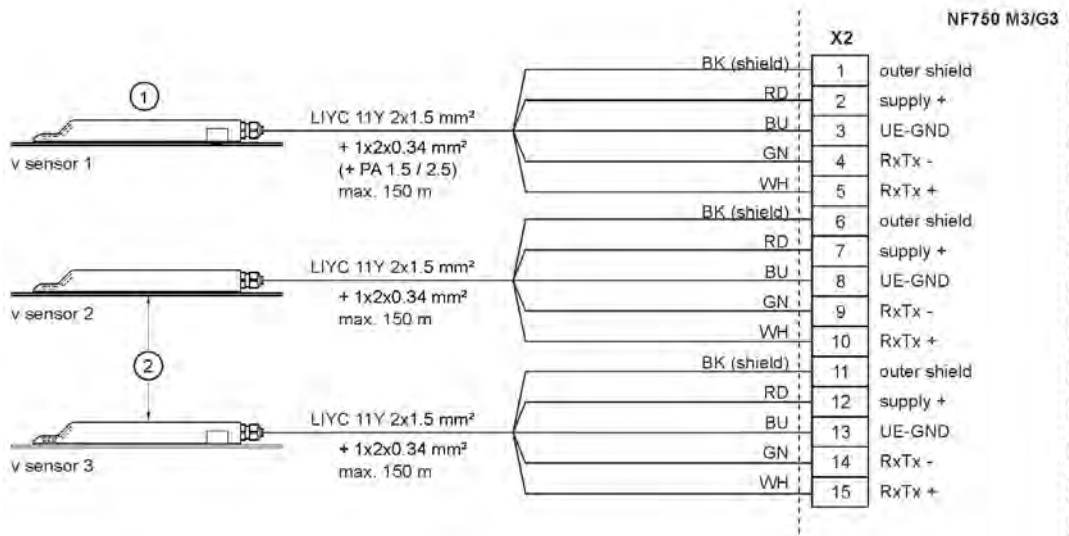

- 1 Sensor 1 (guide sensor) or Electronic Box
- 2 Sensor 2/3 (extra sensor for flow velocity) or Electronic Box

Fig. 23-12 Connecting 2/3 flow velocity sensors to NF750 Type M3/G3

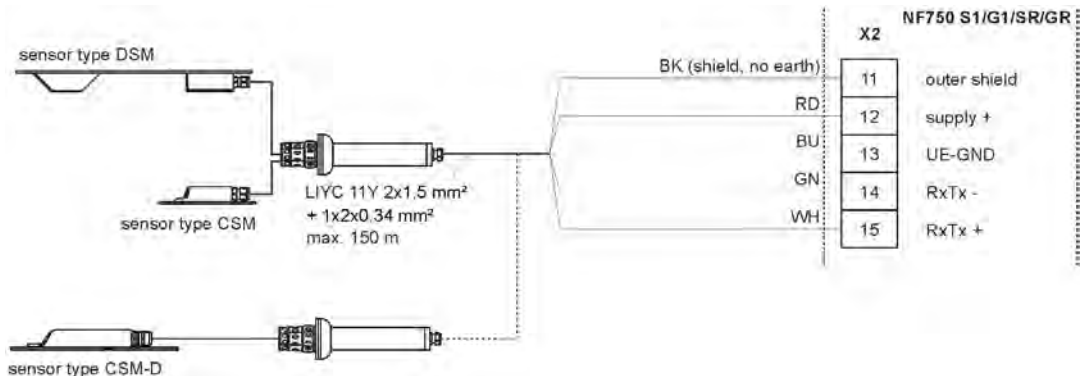

Fig. 23-13 Connecting the Mini sensor family to NF750/700 Type S1/G1/SR/GR

- Connection of a **CSM-D** sensor:
Identical to the CSM/DSM sensor connection.
- Connection of two to three **Electronic Boxes** to NivuFlow 750 Type M3/G3:
Identical to the direct connection of flow velocity sensors in Fig. 23-12.
- Connection of an **Electronic Box** in conjunction with a **DSM** sensor to NivuFlow 750 type M3/G3:
The Electronic Box must always be connected as a guide sensor (v-sensor 1).
- Flow velocity sensor with **integrated pressure measurement cell** at NivuFlow 750 Type M3/G3:
 - Information and details on mounting the sensors can be found in the "Installation Instructions for Correlation and Doppler Sensors"
 - Connection to the terminal for the guide sensor (v-sensor 1).
 - With an integrated pressure measurement cell, a pressure compensation element **must** be used.



Note on the Pressure Compensation Element

The pressure compensation element also serves as a junction box for cable extension. Please note that the maximum cable length from sensor to transmitter (taking into account the maximum permissible cable resistance) must not exceed 150 m in the Ex area.

23.4.2 Connecting Level Sensors

Air-ultrasonic sensor

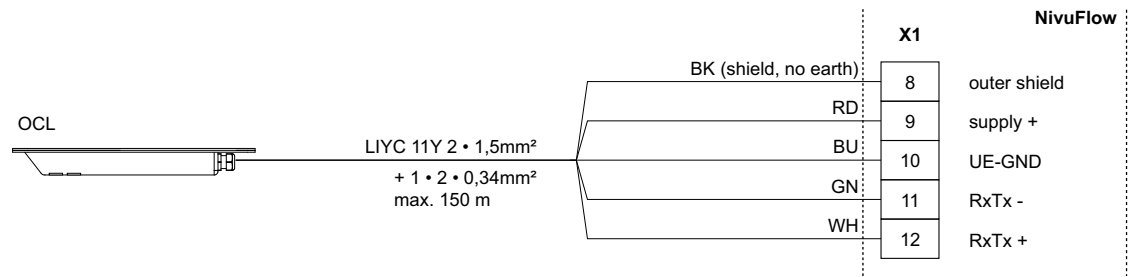

Fig. 23-14 Connection air-ultrasonic sensor Type OCL

2-wire Sensor

The level measurement can also be carried out via a 2-wire sensor (as an alternative to the integrated pressure measurement cell). This level sensor (e.g. i-Sensor, NivuBar Plus pressure probe) is supplied with voltage by the NivuFlow.

- ➡ Connect the 2-wire sensor according to Fig. 23-15.



Fig. 23-15 Connection 2-wire sensor for level measurement

- ➡ If the mA signal of the level measurement is provided by an external transmitter (e.g. NivuMaster), connect the transmitter according to Fig. 23-16.

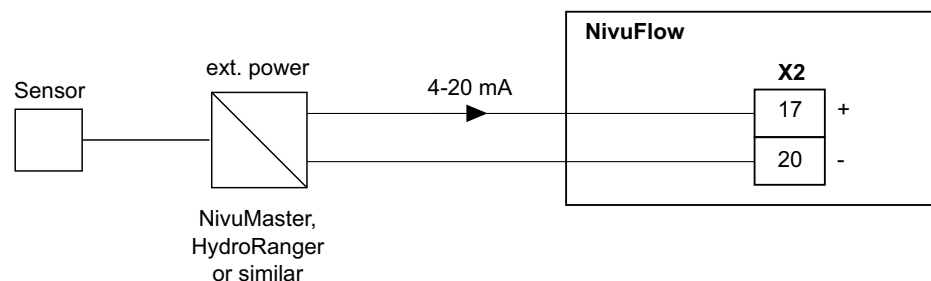

Fig. 23-16 Connection external level measurement

23.4.3 Special features for the connection of sensors in Ex area Zone 1

- OCL sensor:
Connection only on Ex separation module iXT
- 4...20 mA signals from external transmitters:
Connection to the NivuFlow

- i-Sensors with Ex Approval:
 - Zone 1:
Connection only direct to NivuFlow, not to Ex separation module iXT
 - Zone 0:
Connection only direct to Ex separation module iXT, not to NivuFlow

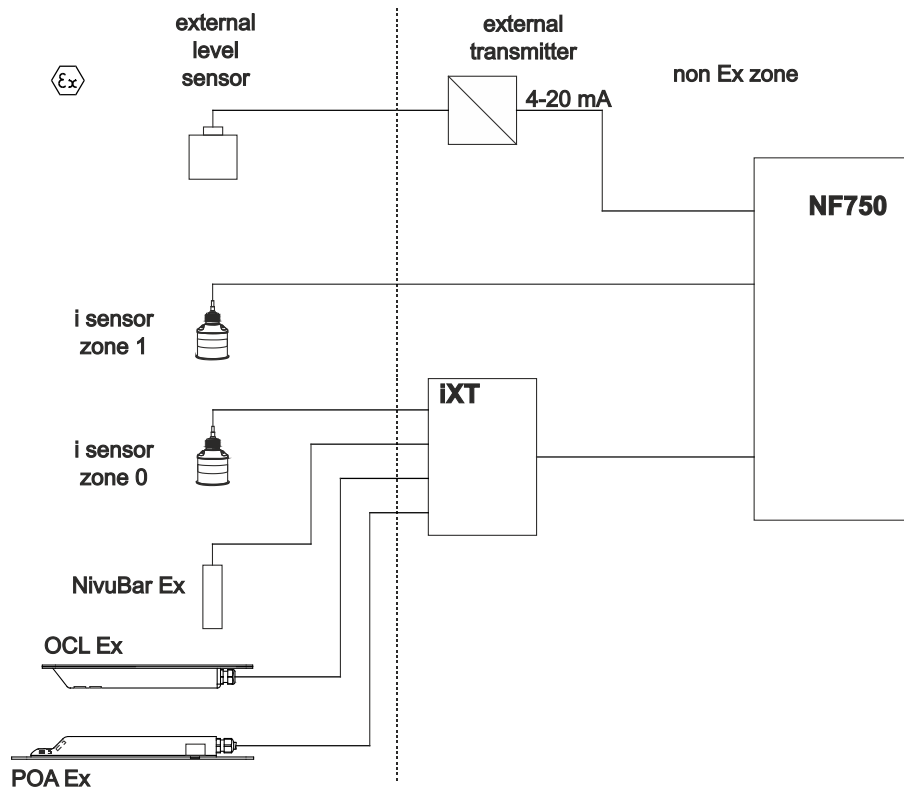

Fig. 23-17 Special features for the connection in Ex area Zone 1

24 Controller Mode

24.1 General



Important Notice

In order to set the controller function correctly and safely, it is essential to have a general basic knowledge of control technology and the parameters and setting procedures used in control technology.

A NivuFlow 750 type SR/GR/M3/G3/M9/G9 transmitter is required to carry out volume control. The standard type S1/G1 is **not** suitable for this, as it has too few inputs and outputs for the slide valve control and is not equipped with the internal software for the control functions.

If the type S1/G1 is nevertheless to be used for volume control, a suitable external controller is also required, which must then be programmed in accordance with the manufacturer's specifications.



Important Notice

Only one control can be set up with the NF750 type M9/G9.

*This control is **permanently assigned** to measurement place 1 and cannot be assigned to the (optionally available) measurement places 2/3.*

Connecting the inputs/outputs to the connections of the control slide actuator



Note on Assignment

The assignment of the inputs and outputs to the controller as well as the analogue input for a possible external control setpoint of the transmitter are **fixed** and cannot be changed.

	Type SR/GR	Type M3/G3/M9/G9
DI Slider Way CLOSED	DI4	DI7
DI Slider Way OPEN	DI5	DI8
DI Slider Torque CLOSED	DI6	DI9
DI Slider Manual	DI7	DI10
DO Slider Way CLOSED	DO4	DO4
DO Slider Way OPEN	DO5	DO5
AI Control Setpoint	AI5	AI5

Tab. 7 Assignment Inputs/Outputs

Instead of the fixed internal setpoint, an external setpoint that can be changed from outside can be used.

This external reference value is applied as a 4...20 mA input signal to analogue input 5 and thus allows, for example, remote control of the discharge volume or automatic basin management via suitable telecontrol devices with a 4...20 mA output signal.

It is also possible to assign an external signal (e.g. via a key switch) to a digital input of the transmitter in order to set the device to OFF mode (MANUAL mode) regarding its control functions during maintenance or repair work.

Use a knife gate valve or wedge gate valve with electric control drive and 3-point step control as the actuator.

Slide valves with an analogue control signal cannot be controlled.

NIVUS recommend the following **operating times** (running time from fully open to closed gate valve) for gate valve selection:

- ≤ DN300: min. 60 seconds
- ≤ DN500: min. 120 seconds
- ≤ DN800: min. 240 seconds
- ≤ DN1000: min. 300 seconds

Depending on the application, however, other settings may also be required.

The provision of the limit switches >OPEN< and >CLOSE< as well as the torque switch >CLOSE< is essential for the correct **control** and **error monitoring** of the slide valve. Apply these signals to the digital inputs of the transmitter.

Make sure that gold-plated versions are selected for the signalling contacts used for the input signals wherever possible. These ensure reliable contact.

When using standard contacts, connect a signalling relay in between. The contacts of this signal relay must be designed in such a way that the input current of 10 mA is safely fed through to the digital input of the transmitter.

Feedback of an **analogue position indicator** of the gate valve to the transmitter is not intended.

The transmitter works as a 3-point step controller with surge detection, quick-close control and slide valve monitoring.

Digital outputs 4 and 5 are predefined for controlling the actuator:

- DO 4: >Close Slide Valve<
- DO 5: >Open Slide Valve<

Analogue input AI 5 is defined for the input of an external reference value.



Note

The assignment of the inputs and outputs to the controller is permanently defined and cannot be changed.

The input current of the digital inputs on the measuring transducer is 10 mA. Reliable contacting of the limit switches must be ensured by selecting the appropriate contact material for the limit switches on the control slide.

24.2 Construction of a Control Section



The detailed installation structure of the measuring and control sections with the required calming sections and dome heights is described in the "Installation Instructions for Cross Correlation and Doppler Sensors".

Make additional use of this information.

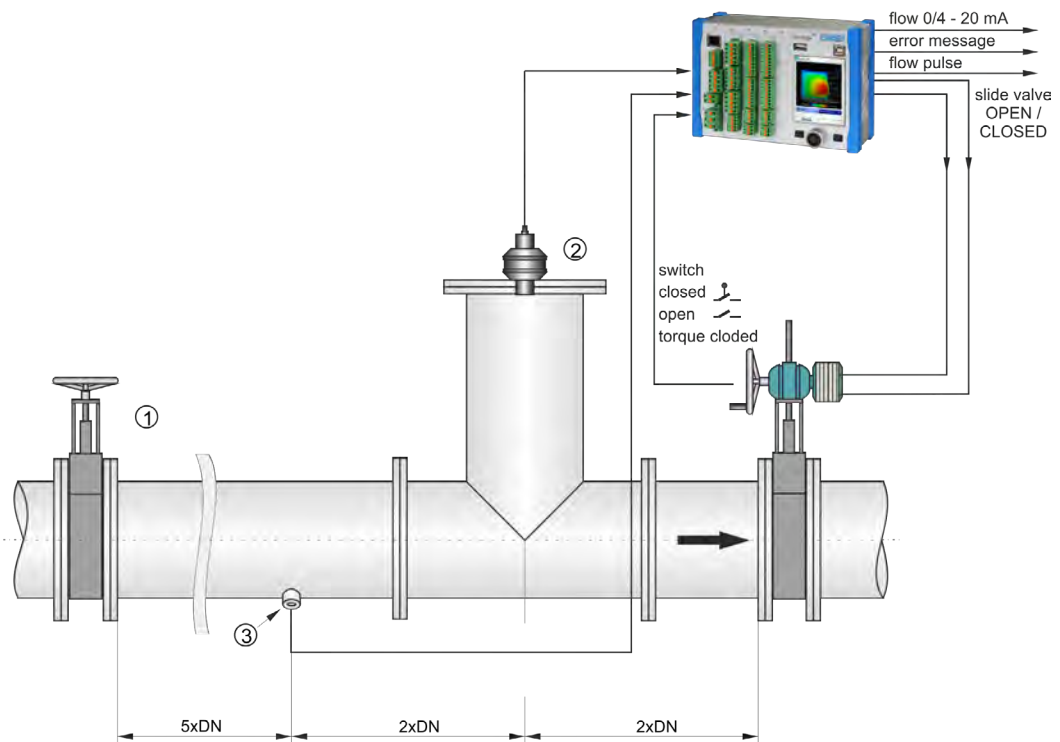

- 1 Manual Slide Valve
- 2 i-Sensor i-03/i-06
- 3 Installation position for pipe flow velocity sensor

Fig. 24-1 Construction of a Control Section using the example of a Discharge Control System

24.3 Wiring Diagrams for Controller Mode

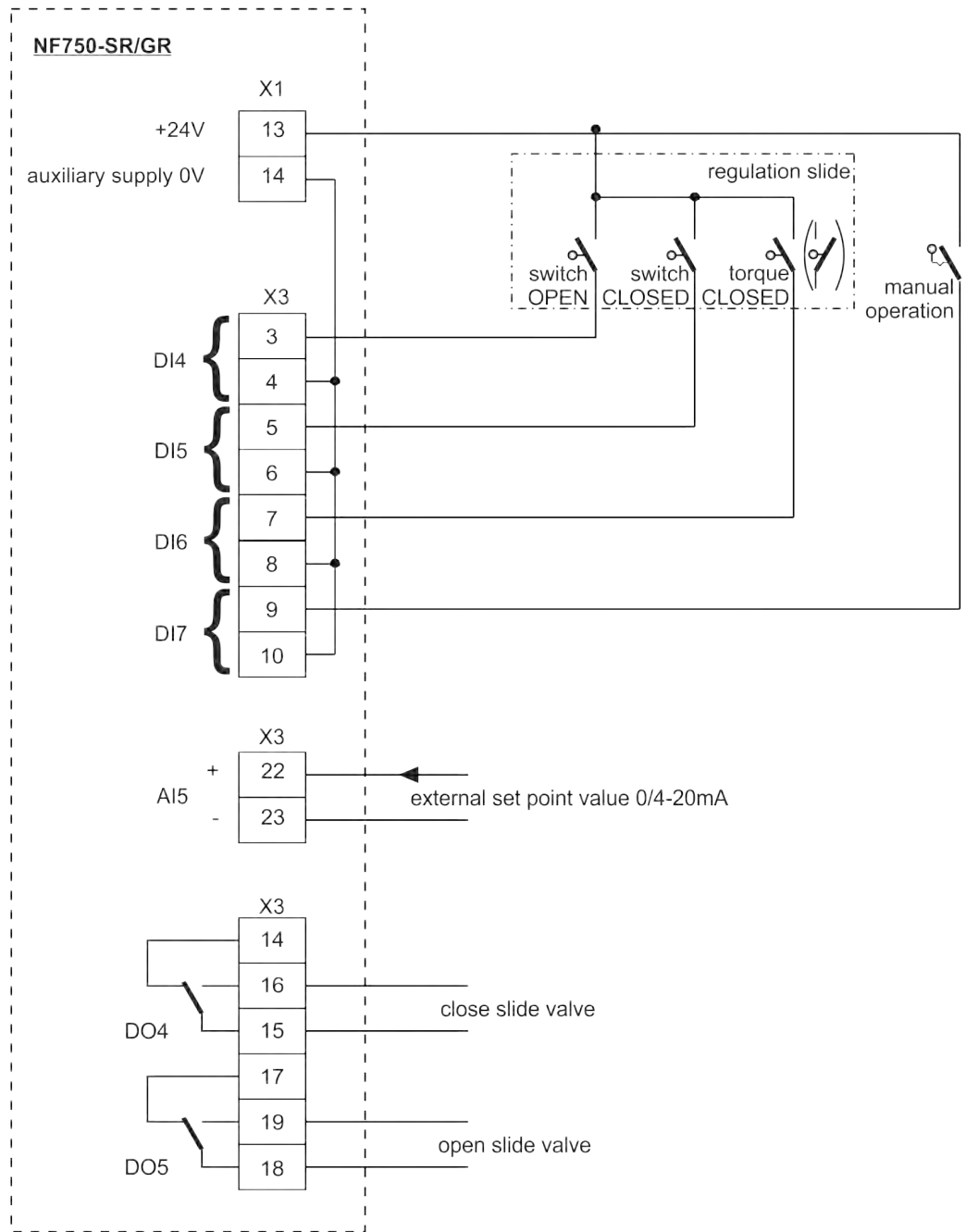

Fig. 24-2 Wiring diagram controller mode NF750 Type SR/GR

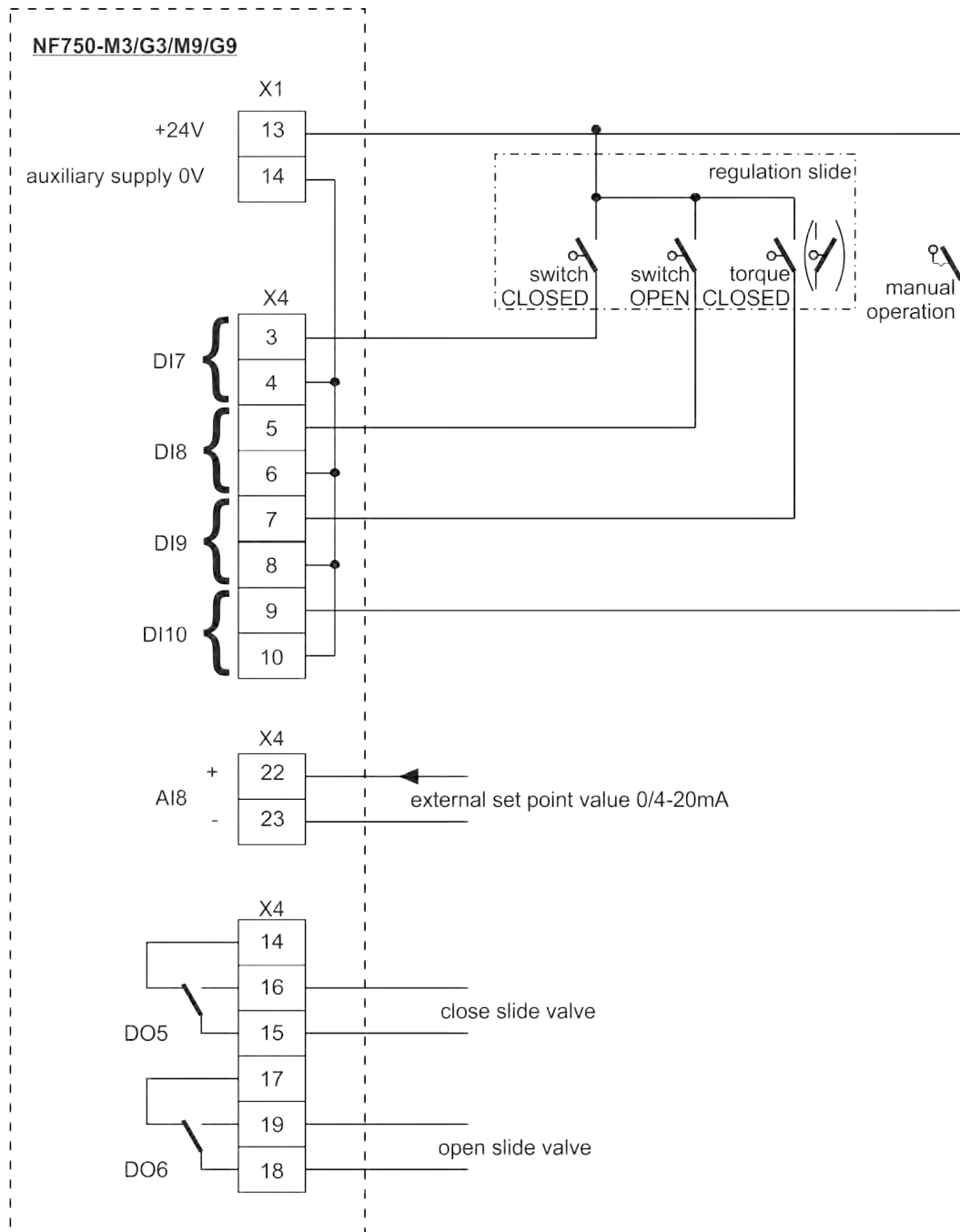

Fig. 24-3 Wiring diagram controller mode NF750 Type M3/G3/M9/G9

24.4 Control Algorithm



Important Notice

Always use all three messages for slider control via the digital inputs.

Activating only one message can lead to malfunctions in control mode.

For the control mode, relay 4 is activated for the >Close Slider< function and relay 5 for >Open Slider<. This assignment **cannot** be changed.

For correct and error-monitored slider control, it is essential to use the >Way CLOSED<, >Way OPEN< and >Torque CLOSED< messages of the slider actuator.

The input current of the digital inputs is 10 mA each.

The controller can be operated with either an external or internal reference value. When using the external reference value, **always** apply it to AI 5.

If a 4...20 mA signal is used as an external setpoint, this signal can be monitored for cable breaks and short circuits. In the event of an error, the transmitter then accesses the internal reference value. Therefore, when using the external reference value of 4...20 mA and error monitoring, **always** programme the internal reference value in addition.

The following relationship applies to the internal calculation of the **slide valve actuating time**:

$$\text{Actuating Time} = (\text{Reference Value} - \text{Flow Rate}_{\text{Actual Value}}) \cdot P_Factor \cdot \frac{\text{max. Slider Runtime}}{\text{max. Flow Rate}}$$



Note

As extensive knowledge of control technology is required to parameterise the controller, no further explanations are given here.

If you are unsure, contact the NIVUS commissioning service.

25 Special Functions of the NivuFlow 750 Type M9/G9

25.1 General

The transmitter NF750 type M9/G9 is a special version within the NF750/700 transmitter series.

It is designed to manage up to nine (in a special configuration with three additional NF750 type M9/G9 up to 27) flow velocity sensors and, depending on the version, to calculate one to three flow measurement places.

Areas of Use

- For applications with only **one measurement place**, the use of type M9/G9 is particularly suitable
 - for very wide channels (several metres wide) and/or
 - for strong structures (dry weather channels, banks, etc.),
 - for hydraulically heavily disturbed profiles and
 - for very high demands on measurement accuracy.
- Transmitters of type M9/G9 with the option of calculating and managing **two or three measurement places** are used when
 - only limited space is available for the installation of the transmitter in the case of retrofitting and/or
 - several flow measurement results are to be summarised to a total flow sum or
 - a second subtotal is to be calculated from a measured total and partial flow rate.
- Furthermore, the complex design of this type allows the additional integration of external flow rates (e.g. 4...20 mA signal from an external EMF) into the calculated overall result.

Application/measurement place 1 can be parameterised as a **step controller**. All other measurement places cannot be parameterised for this, as there are not enough digital inputs and outputs available in the hardware.



Special applications possible

The NivuFlow 750 type M9/G9 transmitter with multi-measurement place functionality and an optional licence for Modbus coupling can be used as a special application with several levels.

In this case, two to three additional NivuFlow transmitters (also with Modbus coupling) are connected instead of the iXT/MPX for expansion. The iXT/MPX (only for NivuFlow 750) can then be connected to these again and the number of possible flow velocity sensors can be increased to up to 27.

Alternatively, structured measurement sections within complex measurement tasks can be realised by combining with other measurement methods (transit time, surface velocity radar) (see also Chap. "19 Areas of Use" and "25.5 Basic structure of multi-measurement places (via Modbus coupling)").

This function option requires a lot of experience with the parameterisation of the transmitters used and should always be carried out by specially trained NIVUS personnel. For this reason, we will not go into the programming details here.

25.2 Connecting the Flow Velocity Sensors

When using a type M9/G9, the flow velocity and associated level sensors are **always** connected to the transmitter via the iXT Ex Separation Module or MPX Multiplexer, **never** directly to the transmitter itself.

Up to 3 flow velocity sensors can be connected to each iXT or MPX.

Number of sensors	Number of Ex Separation Modules/Multiplexers
1...3 Sensors	1x iXT/MPX
4...6 Sensors	2x iXT/MPX
7...9 Sensors	3x iXT/MPX

Tab. 8 Required iXT/MPX

Internally, the sensors are "counted through" from the first to the third iXT/MPX. That means:

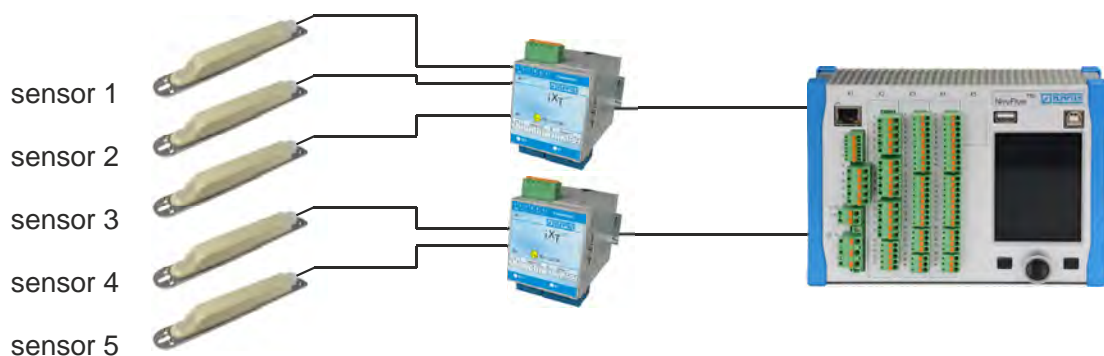

Fig. 25-1 Numbering of Sensors

If a **combi sensor** (sensor with integrated height measurement) is also used, it should be connected as sensor 1 and also mounted at the lowest point in the channel.

If a combi sensor is also used in the **next application**, this is **sensor 1** of the second application.

Ex Separation Module iXT

The following can be connected to the iXT Ex Separation Module:

- POA Zone 1
- CS2 Zone 1
- i-Sensor Zone 0
- NivuBar Plus Zone 1
- 2-wire sensors from other manufacturers (provided that the Ex approval meets the requirements)
- Air-ultrasonic sensor OCL Zone 1
- EBM Electronic Box

DANGER



Risk of explosion when connecting external 4...20 mA signals (filling level)

*External 4...20 mA signals (coming from other transmitters) must **never be connected** in Ex zone applications in combination with transmitters type M9/G9 for safety reasons. Not directly to the transmitter and not to the iXT Ex Separation Module.*

Disregarding may lead to personal injury.

Multiplexer MPX

The following can be connected to the MPX Multiplexer:

- POA
- CS2
- i-Sensor
- NivuBar Plus
- 2-wire sensors from other manufacturers (provided that the permissible voltage and the load match)
- Air-ultrasonic sensor OCL
- EBM Electronic Box
- up to 2 external 4...20 mA level signals (e.g. from the NivuMaster)

Connecting analogue and digital inputs

Analogue and digital inputs (unbound measurement values from other measurement devices, external controller setpoint, measurement enable, slider end position etc.) are connected directly to the measuring transmitter and not to the iXT/MPX.

Numbering and connection of sensors for multiple applications

Each application can contain a different number of flow velocity sensors (up to a maximum of 9). Example:

- Application 1: one flow velocity sensor
- Application 2: five flow velocity sensors
- Application 3: two flow velocity sensors

All sensors are "counted through", i.e. the flow velocity sensors 1...3 are connected to the iXT/MPX 1, the flow velocity sensors 4...6 to the iXT/MPX 2 etc.

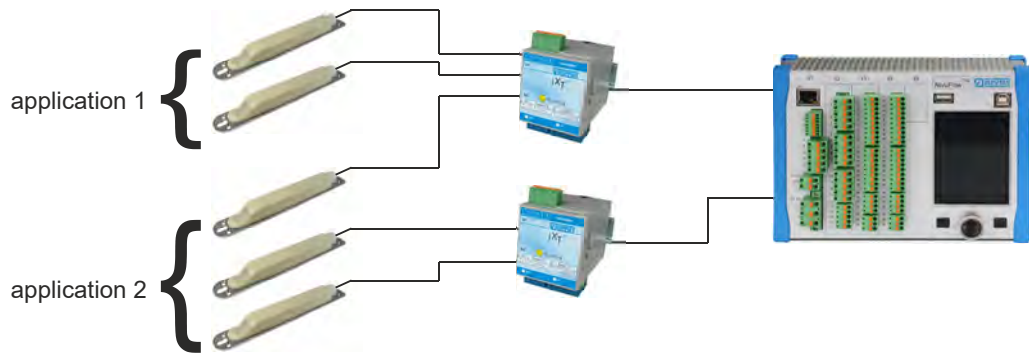

Fig. 25-2 Numbering/Connection for multiple Applications (Option 1)

The iXT/MPX do not have to be fully wired. Sensor connections can also remain free in between. In the parameterisation, these sensors are then to be parameterised/displayed as "not active".

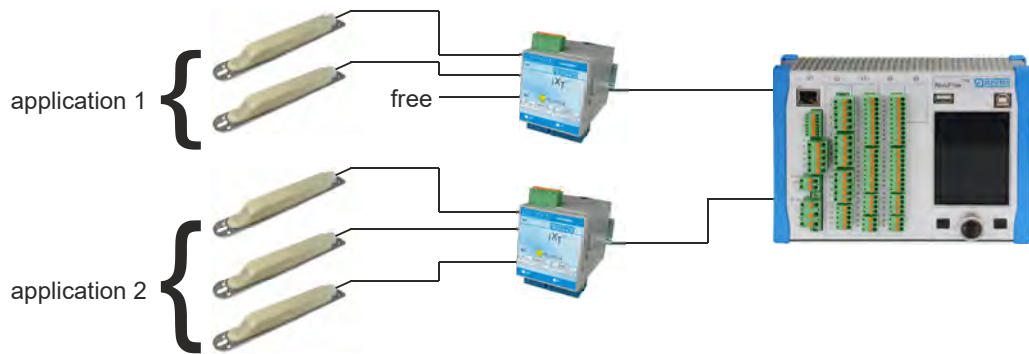

Fig. 25-3 Numbering/Connection for multiple Applications (Option 2)

25.3 Connecting the Level Sensors

The level sensors of application 1 are connected to iXT/MPX 1, the level sensors of application 2 to iXT/MPX 2 and the level sensors of application 3 to iXT/MPX 3, even if the v-sensors associated with the corresponding application are **not** connected there.

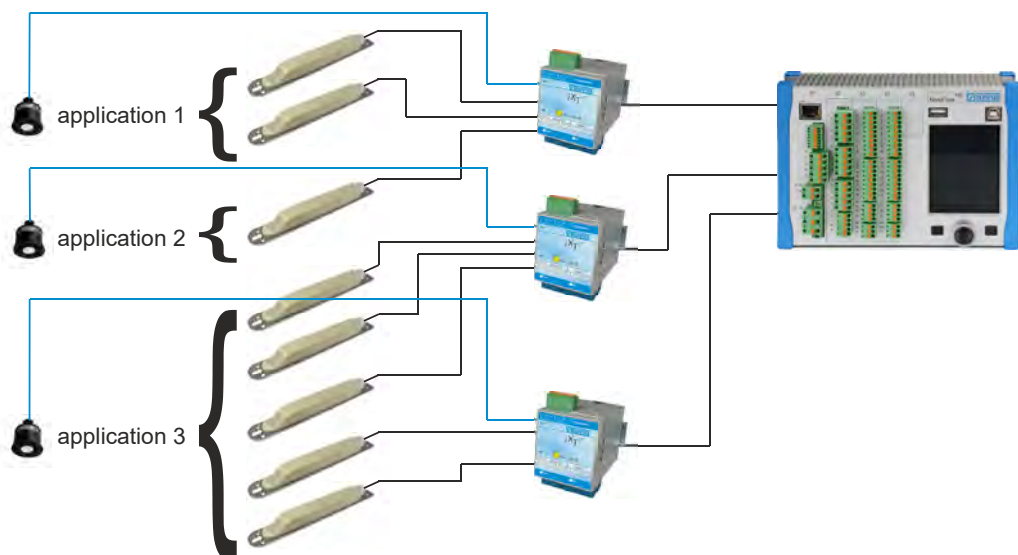

Fig. 25-4 Connecting the Level Sensors

Level Measurement in Ex Area

In combination with the transmitter type M9/G9, intelligent i-Sensors may only be used in Ex areas if they have the appropriate Ex approvals.



Important Notice

Approval for Ex zone 0 is required. The approval of the i-Sensors for Ex zone 1 is an approval according to ignition protection type "Encapsulation". However, only intrinsically safe powered sensors (i-Sensor intrinsically safe powered = Zone 0) may be connected to the iXT.

The i-Sensor Ex-Zone 0 is connected to the iXT, not directly to the transmitter.

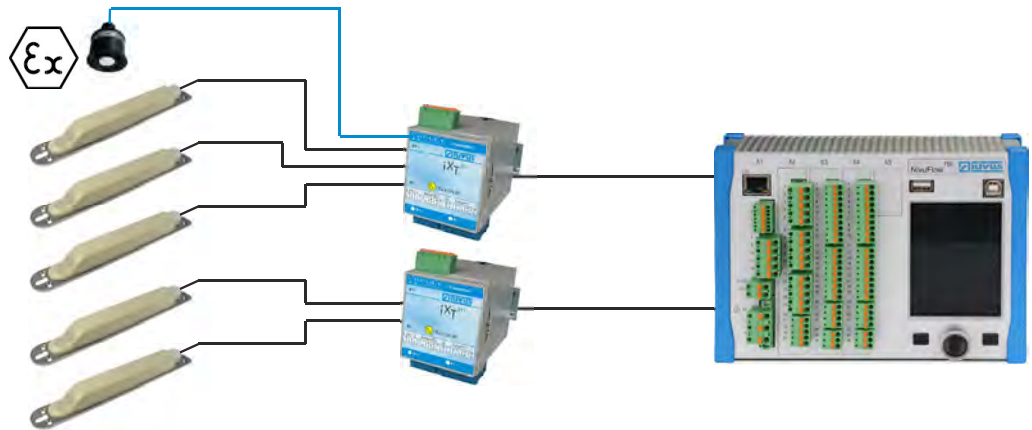

Fig. 25-5 Connecting an i-Sensor in Ex areas

25.4 Connecting the Ex Separation Module/Multiplexer to NivuFlow 750 Type M9/G9 transmitter

The iXT Ex Separation Module iXT or the MPX Multiplexer are connected to terminal strip X2.

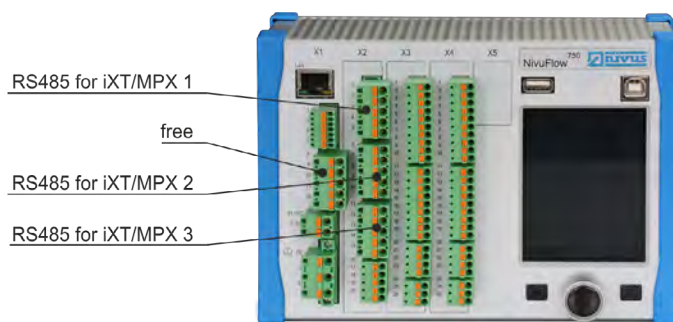

Fig. 25-6 Connections on NivuFlow 750 Type M9/G9

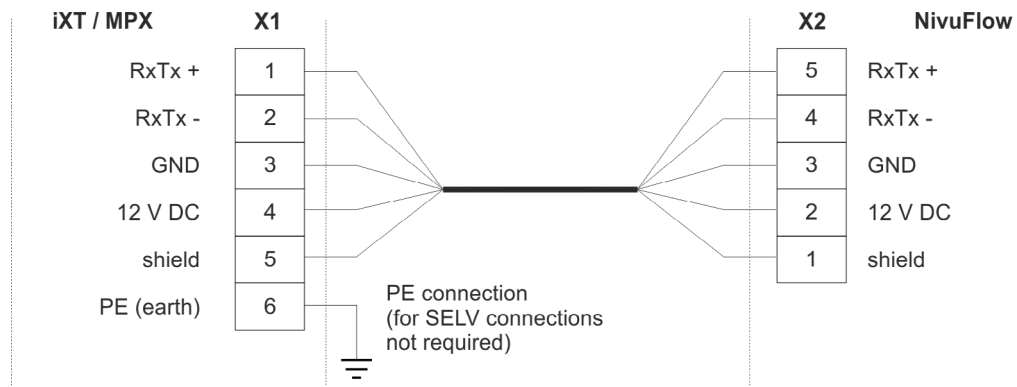

Fig. 25-7 Connecting the first iXT/MPX to NF750 Type M9/G9

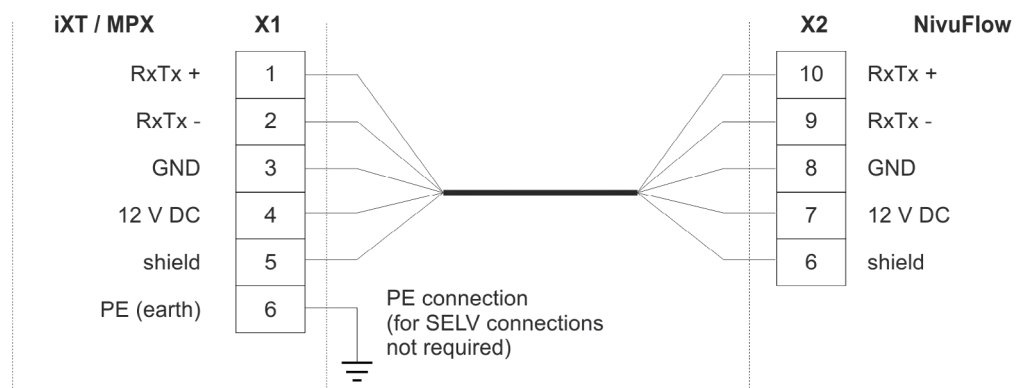

Fig. 25-8 Connecting the second iXT/MPX to NF750 Type M9/G9

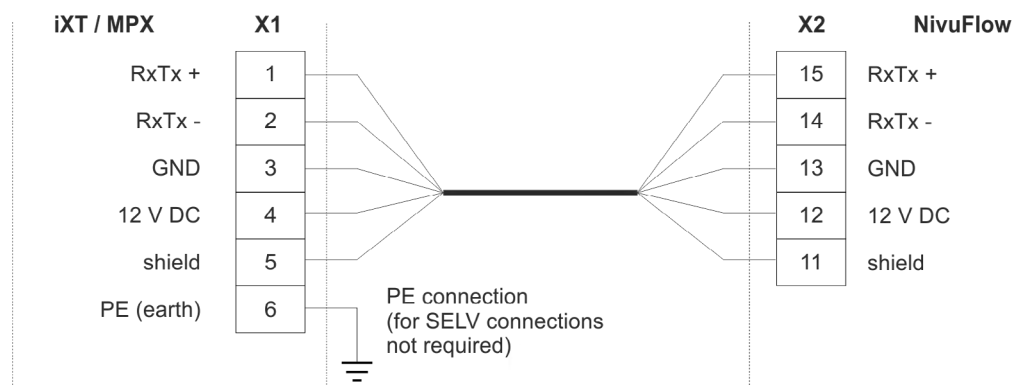

Fig. 25-9 Connecting the third iXT/MPX to NF750 Type M9/G9



Further information on the connection between iXT and MPX, cable types, maximum distances, overvoltage protection etc. can be found in the "Technical Description for the iXT0 Ex Separation Module" and the "Technical Description for the MPX Multiplexer".

25.5 Basic structure of multi-measurement places (via Modbus coupling)

If a special multi-measurement place is to be set up with more than the nine connectable sensors that are normally available with a NivuFlow 750 Type M9/G9 transmitter with multi-measurement place capability, this can be done using the Modbus coupling device licence, which can be booked additionally.



Note

The setup and parameterisation of a multi-measurement place are very specific, which is why such an application is only recommended by NIVUS if the work is carried out by trained NIVUS service technicians from the headquarters in Eppingen.

Contact the NIVUS customer centre if required (see Chap. “53.2 Customer Service Information”).

Here is an example of a possible application. However, no further parameterisation information/details are provided, as this must be done on a very individual basis.

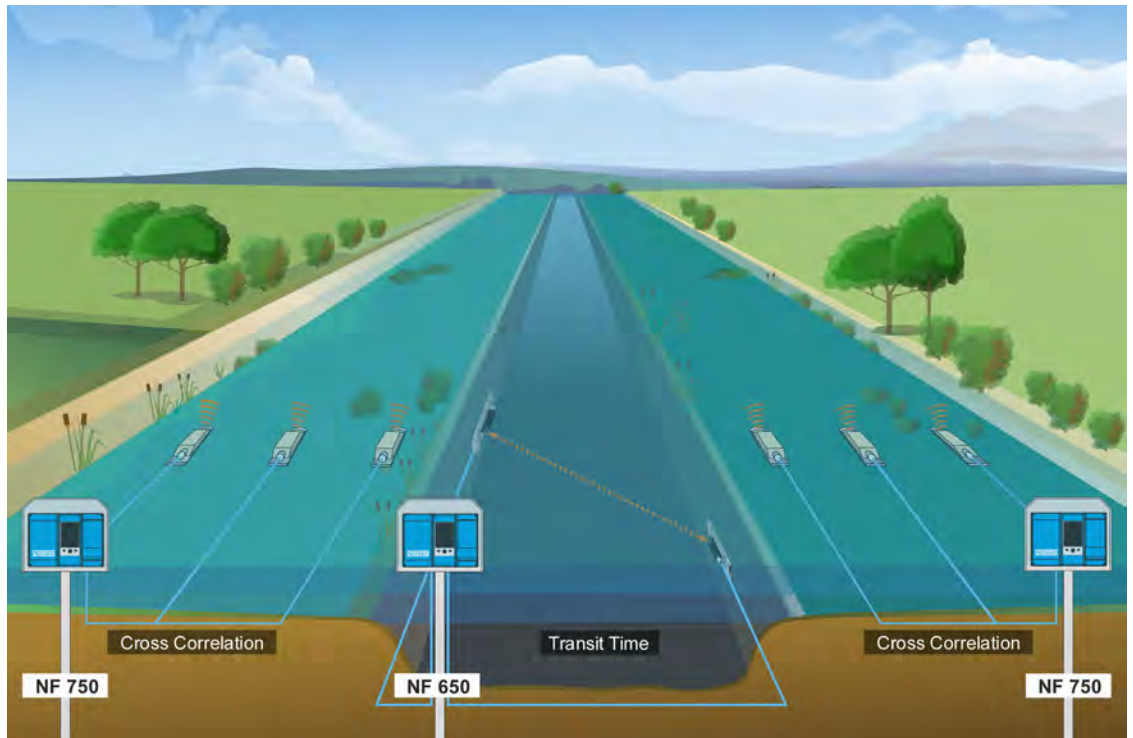

Fig. 25-10 Example: Multi-measurement place cross-correlation and transit time

The connection is made using a master-slave principle, whereby the master must be a NivuFlow 750 type M9/G9 measurement transmitter with three activated measurement places and the activated Modbus coupling device licence. Up to three slaves can be connected to it. These slaves are NF5/NF6/NF7/N75 transmitters (all the same or different, depending on the measurement task).

The transmitters are connected via Modbus RTU or Modbus TCP.

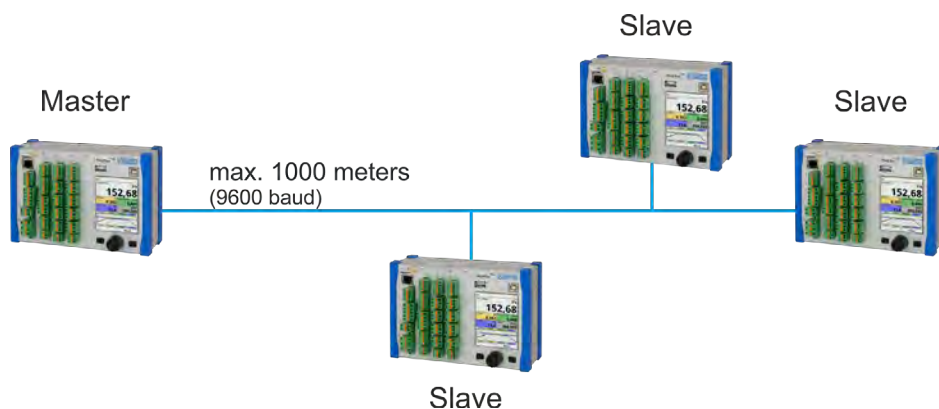

Fig. 25-11 Example: Connection via Modbus RTU

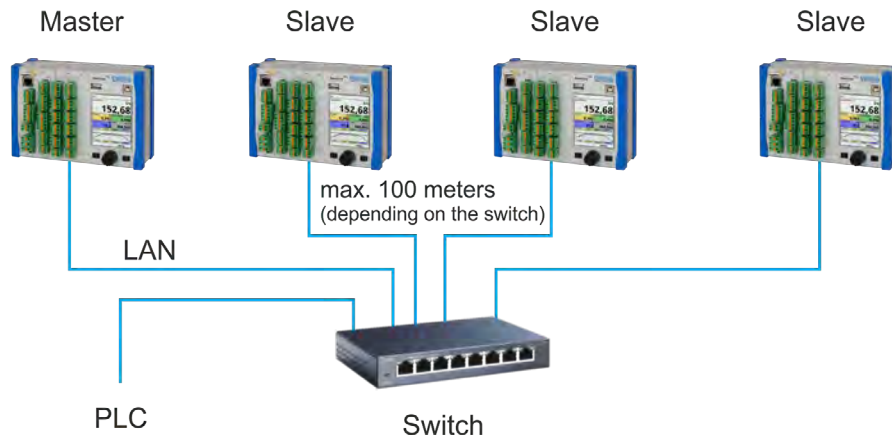

Fig. 25-12 Example: Connection via Modbus TCP

In this way, it is possible, for example, to combine several different measurement methods in one measurement place and, depending on requirements, to measure differently in each measurement section.

26 Overvoltage Protection Measures

In the NivuFlow transmitter, basic overvoltage protection is provided by installing surge arresters in the area of the mains supply and the sensor connections. For effective protection of the NivuFlow it is nevertheless necessary to protect the power supply as well as the mA outputs and mA inputs using additional external overvoltage protection devices.

NIVUS recommend the types EnerPro 220Tr or EnerPro 24Tr (with 24 V DC power supply) for the mains side. For the mA outputs/inputs NIVUS recommend the type DataPro 2x1 24/24Tr.

The flow velocity sensor used and the air-ultrasonic sensor type OCL are already internally protected against overvoltage. If a high hazard potential is expected, these can be protected by combining the types DataPro 2x1 12 V/12 V 11 μ H-Tr (N) and SonicPro 3x1 24 V/24 V.

DANGER



Do not install the overvoltage protection together with the transmitter in the ZUB0 NFWx field enclosure

The ZUB0 NFWx field enclosure is designed to accommodate a maximum of one NF7 and one Ex Separation Module iXT.

If overvoltage protection devices are installed at this location instead of the iXT, there is a risk of inadmissibly high voltages being induced directly onto the transmitter electronics when the protective device is triggered (due to the close proximity). When the overvoltage protection is triggered, a brief, strong magnetic field is generated.

This means that there is no reliable protection against overvoltage despite the use of overvoltage protection devices.

- *Overvoltage protection devices must be installed at least 10... 15 cm away from the transmitter.*
- *The cross-section of the overvoltage conductor must be at least 1.5 mm² and must not be longer than 1 metre. In addition, larger cross-sections must be selected or the arrester must be placed directly on an arrester strip.*

The spatial separation of the unprotected side and the arrester from the protected side must be strictly observed: Spatial separation of the incoming and outgoing cables at the overvoltage protection element from the outgoing, protected cables.



Consider connected loads, capacitances and inductances

In connection with the use of the sensors in Ex areas, the electrical connection values of the overvoltage protection elements as well as the capacitances and inductances of the NIVUS sensor cable (Type LiYC11Y 2x1.5 + 1x2x0.34) must also be taken into account.

The following NIVUS cable lengths are permissible in Ex areas:

- One-sided overvoltage protection: 135 m
- Two-sided overvoltage protection: 120 m



Reduction of the possible cable lengths

The use of overvoltage protection elements for the sensors in the non-Ex area reduces the maximum possible cable length.

The series resistance of the overvoltage protection element is 0.3 Ohm/wire. This resistance must be included in the permissible total resistance; see technical description or operating instructions of the sensors.



Observe connection direction

Ensure that the connection is on the correct side (p-side towards the transmitter) and that the cable feed is correct and straight. The down conductor (earth) must be necessarily routed in the direction of the unprotected side.

Incorrect connections disable the function of the overvoltage protection.

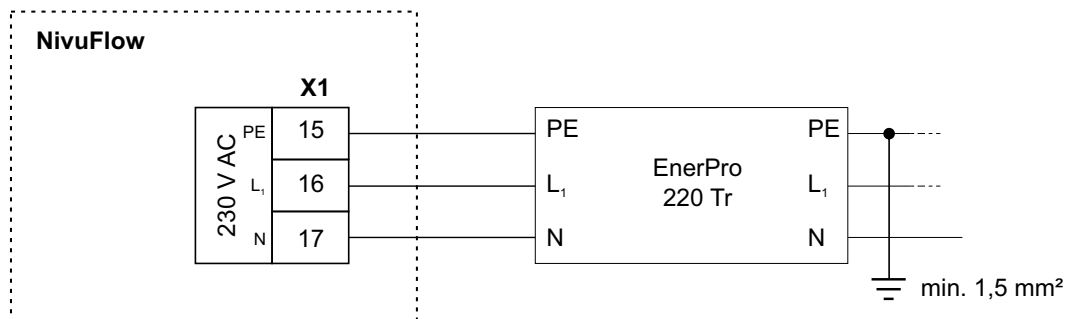

Fig. 26-1 Overvoltage protection for AC power supply

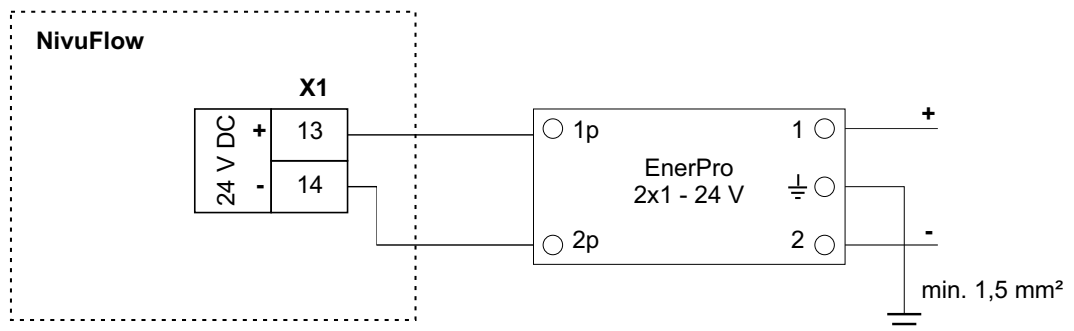

Fig. 26-2 Overvoltage protection for DC power supply

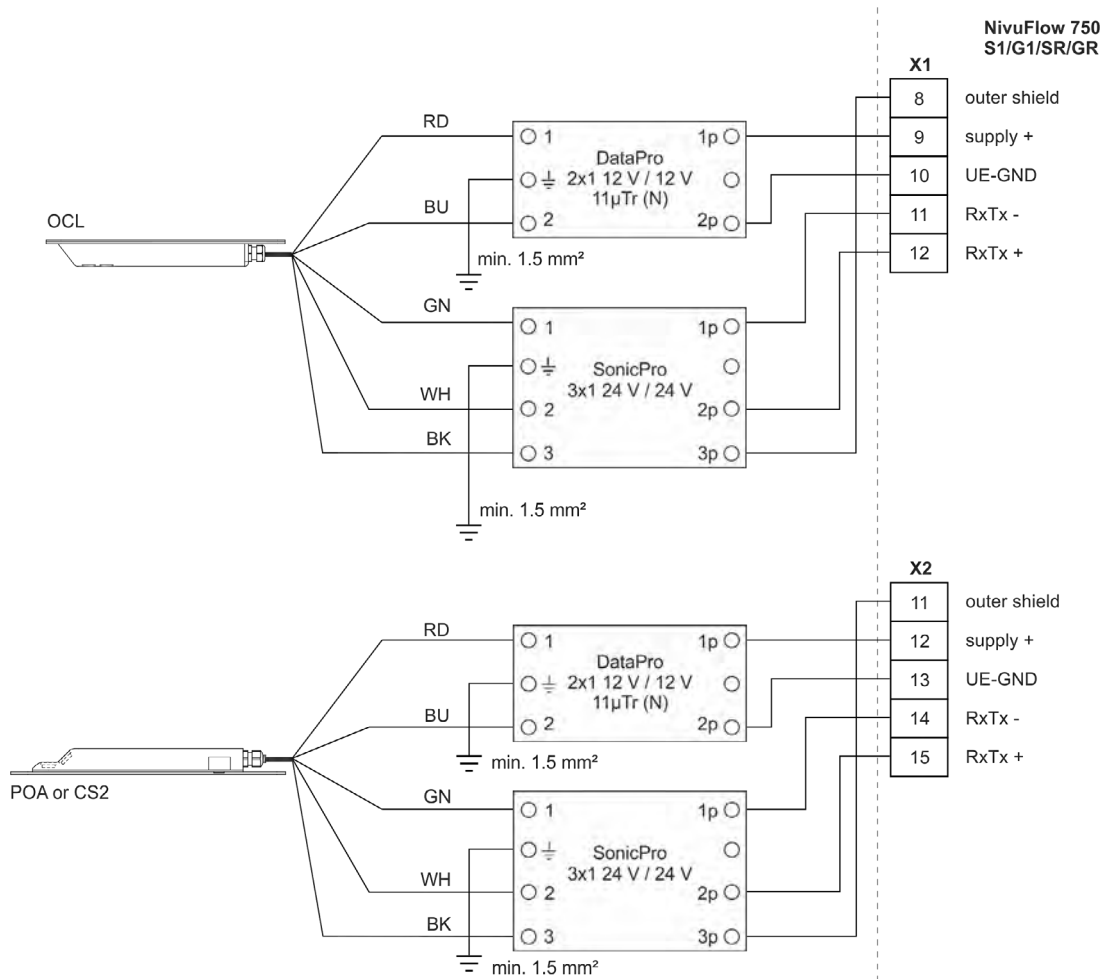

Fig. 26-3 Sensor overvoltage protection for S1/G1/SR/GR

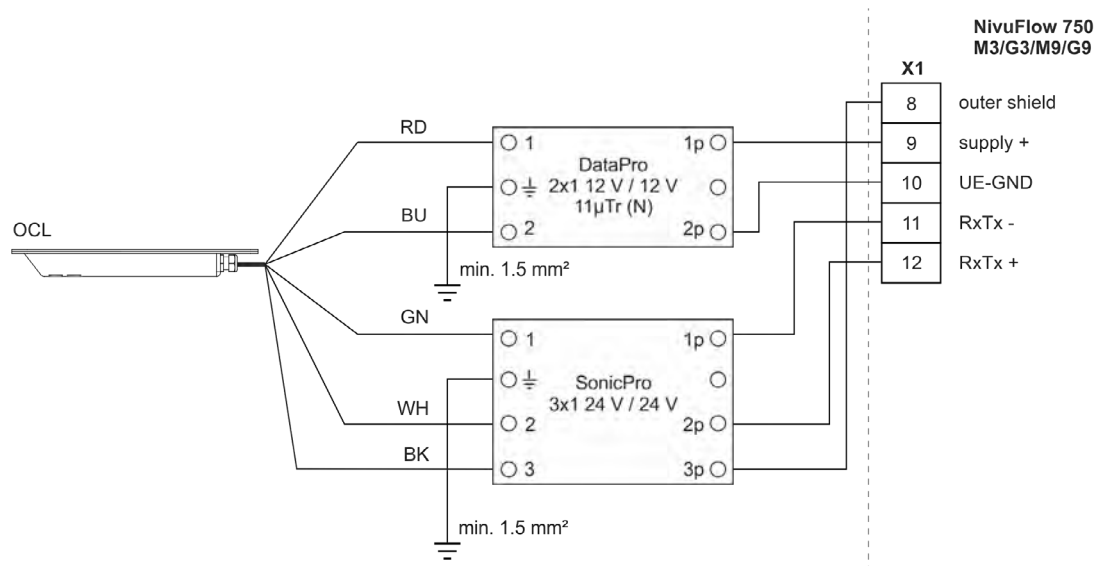

Fig. 26-4 Overvoltage protection OCL air-ultrasonic sensor on M3/G3/M9/G9

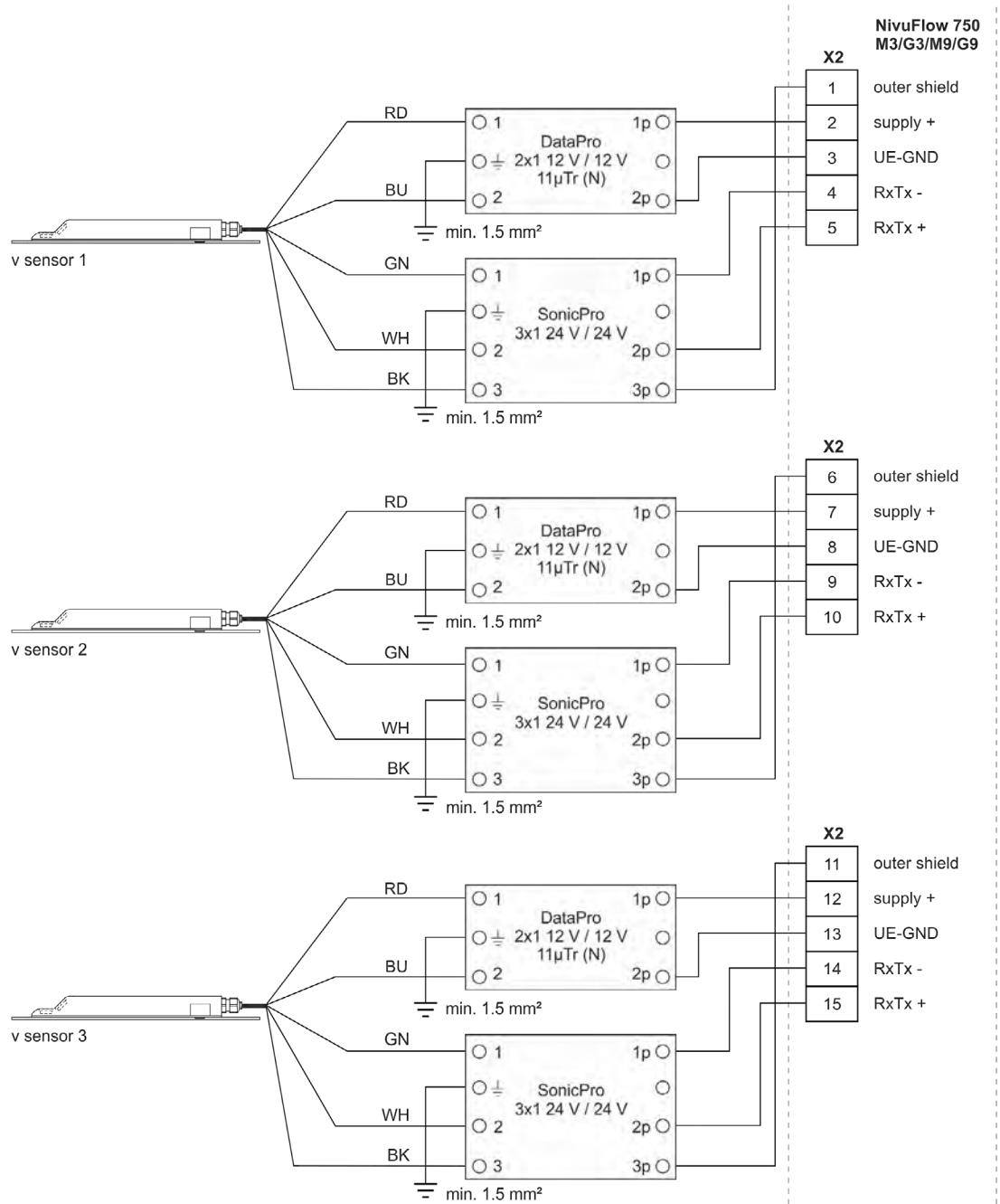

Fig. 26-5 Overvoltage protection flow velocity sensors on M3/G3/M9/G9

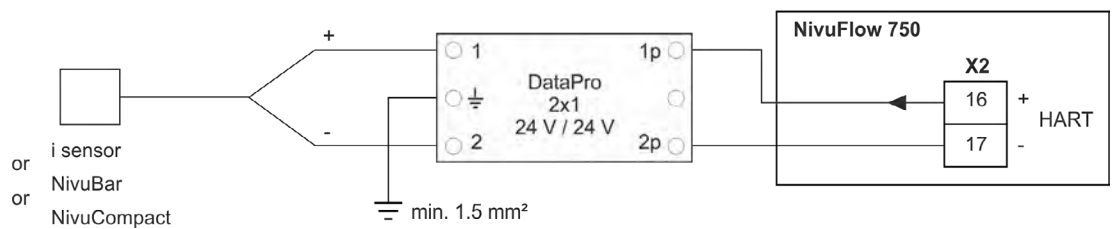

Fig. 26-6 Overvoltage protection external level measurement

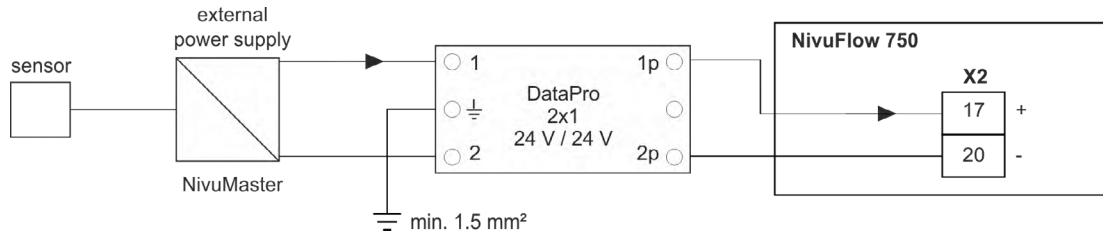

Fig. 26-7 Overvoltage protection analogue input of ext. transmitters

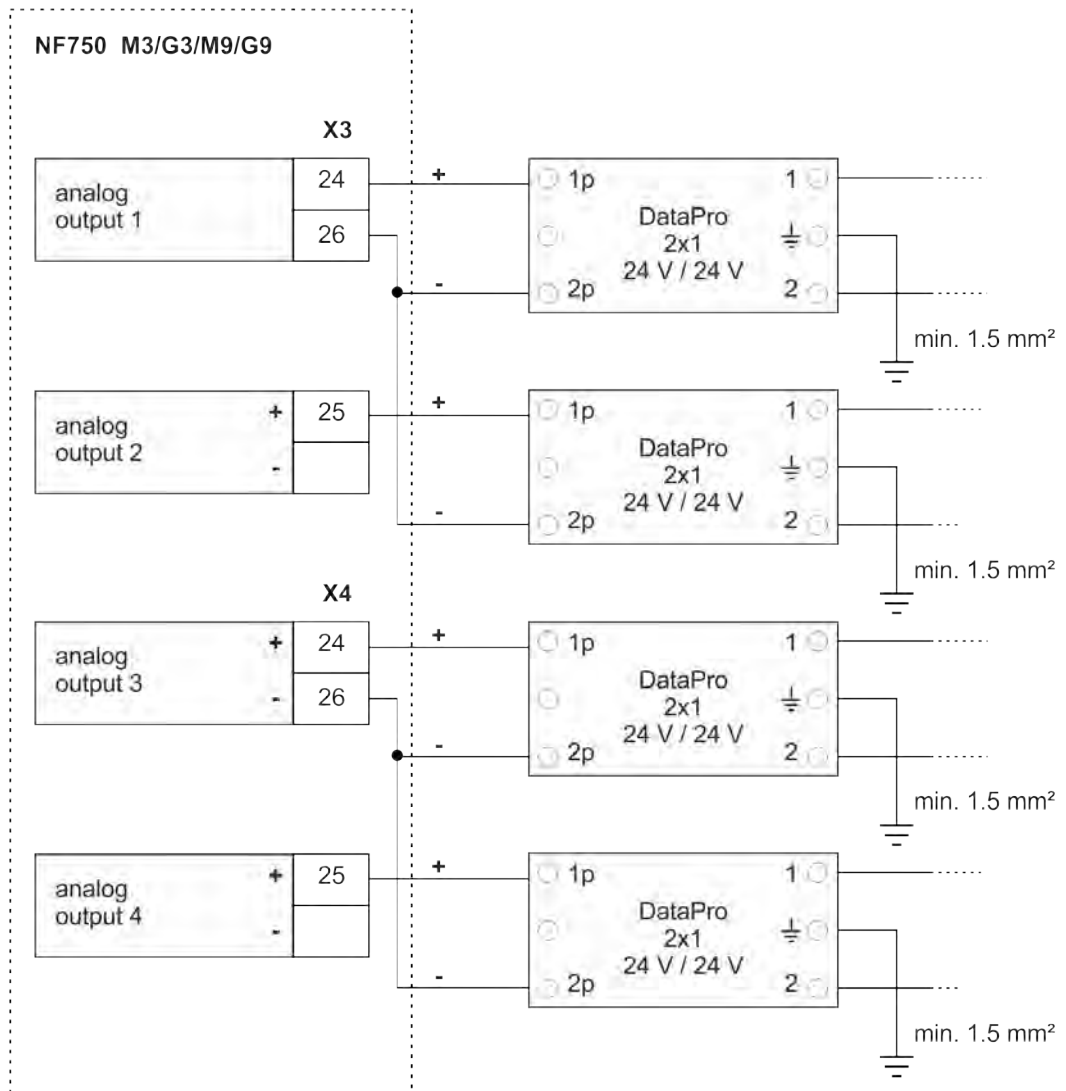

Fig. 26-8 Overvoltage protection analogue outputs NivuFlow 750 Type M3/G3/M9/G9

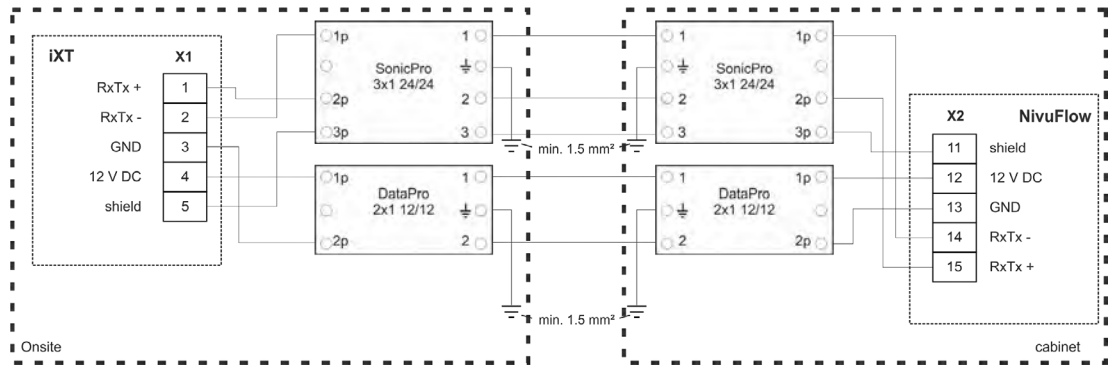

Fig. 26-9 Overvoltage protection iXT on NivuFlow 750/700 Type S1/G1/SR/GR



Note on discharge (earthing)

The minimum conductor cross-section is 1.5 mm² (not for stranded wires).

The maximum permissible cable length of the arrester is 1 m. In addition, it must be laid on a down conductor rail.

Commissioning

27 Notes to the User

Before connecting and operating the NivuFlow, the instructions below shall be followed.

This instruction manual contains all information required for parameterisation and use of the device. The instruction manual is intended for qualified expert personnel. Appropriate knowledge in the areas of measurement systems, automation technology, control engineering, information technology and wastewater hydraulics are preconditions for putting the NivuFlow into operation.

Read this instruction manual carefully to ensure proper functioning of the NivuFlow. Connect the NivuFlow according to the specified connection diagrams in Chapter "22.2 Terminal Wiring Diagrams".

If you have any questions regarding installation, connection or parameter setting, please contact our hotline at:

- +49 7262 9191-955

General Principles

Commissioning of the measurement system shall not be carried out before installation has been finished and verified.

Observe the information in this instruction manual to prevent incorrect or faulty or parameterisation. Familiarise yourself with the operation of the transmitter using rotary pushbutton, function keys and display before you start parameterisation.

After connecting the transmitter and sensors (according to Chapters "22.1 Connection to the spring-cage terminal blocks" and "23.4 Connecting Sensors to NivuFlow") the measurement place must be parameterised.

To do this, in most cases it is sufficient to specify:

- Measurement place geometry and dimensions
- Sensors used and their positioning within the application
- Working range of the sensors used
- Display units / language
- Function and span of analogue outputs as well as function and corresponding detailed parameterisation of digital outputs

The user interface of the NivuFlow is easy to understand. You can quickly make the **basic settings** yourself.

The parameterisation of the device should be carried out by NIVUS or by a specialist company authorised by NIVUS if one or more of the following conditions apply to you:

- Using the NF750 Type M9/G9 transmitter
- Comprehensive programming tasks
- Difficult hydraulic conditions
- Special Channel Shapes
- Controller Settings
- Service specifications required a setting and error log
- Qualified personnel not specially trained or with little metrological experience

28 Principles of Operation

The entire operation of the NivuFlow is done via the control elements (see Chapter "2.2 NivuFlow Control Elements"). A rotary pushbutton and two function keys are available for parameterisation and entering required data.

The display shows at any time where entries are currently being made in the menu.

28.1 Overview Display

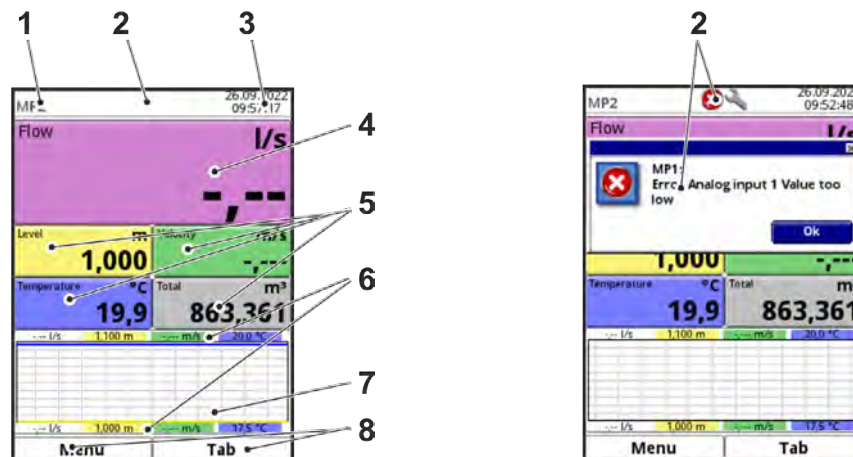

- 1 Measurement Place Name
- 2 Possible error message, system status information or display for active parameterisation or service mode
- 3 Date/Time
- 4 Display Area 1 (output field 1 for the flow rate)
- 5 Display Area 2 (output field 2...5 for level, wetted hydraulic area, analogue output X, medium temperature, air temperature, totals, daily average or, with the combi measurement place of the NF 750 Type M9/G9, for measurement place 1/2/3 and totaliser)
- 6 Automatic scaling for display area 3 (Pos. 7)
- 7 Display Area 3 (trend graph on level, velocity, medium temperature and flow rate)
- 8 Function displays for the assignment of the keys

Fig. 28-1 Main Screen (with default settings)

28.2 Using the Control Elements

➡ Select >Main Menu< by pressing the left function key.

1. Turn the rotary-push button until the desired menu or the corresponding parameter is highlighted blue.
2. Press the rotary pushbutton to go to the next parameter level or to enter the corresponding parameter.

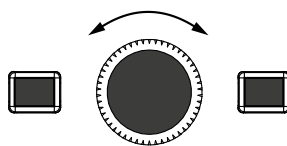

3. Repeat the procedure until the desired menu or parameter is reached.
Designations or **numerical values** can be entered for parameters.

➡ See Chapters "28.3 Input via Keypad" and "28.4 Input via Numeric field".

4. Press the left function key to exit the menu step by step.
The device continues to work in the background with the last set values during the parameterisation process.

The following prompt for **saving the changed parameters** does not appear in the display before the current parameterisation process has been completed and confirmed.



Fig. 28-2 Query for saving the parameters

5. Confirm entry with >YES<.
A **password request** follows.



Fig. 28-3 Password request after setting the parameters

6. Enter password (default password "2718").
The NivuFlow takes over the new parameters at this point and continues to work with these values.

Depending on the parameterisation, the transmitter restarts the evaluation and calculation in the background. To prevent the display and analogue and digital outputs from going to "0" or putting out errors or limit violations that do not make any sense at this moment, the transmitter holds the display and output of the last measured value for a period of about 10...20 seconds after programming has ended. This state is represented by showing an "H" (= Hold) in the upper line of the display (Fig. 28-4). As soon as the new valid measurement values are available, this "H" disappears and the transmitter returns to the display and output of the newly determined valid measurement values.

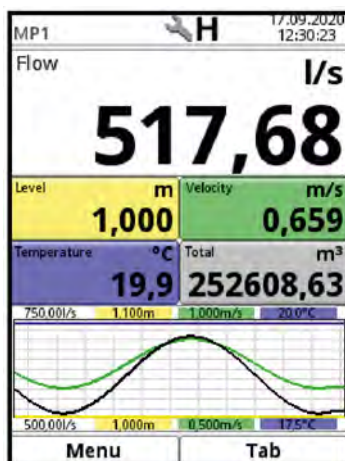
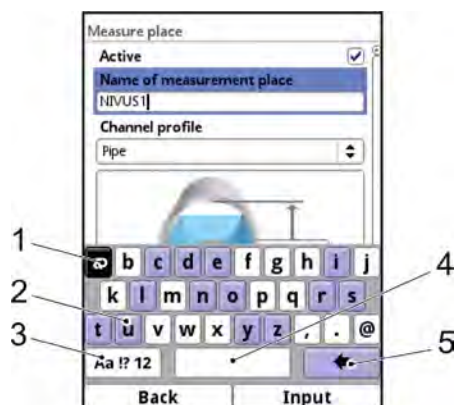

Fig. 28-4 Main Screen with Hold Symbol

28.3 Input via Keypad

Names or designations can be entered in some parameters. When selecting such a parameter, a keyboard field opens in the lower part of the display.



- 1 Selected Field
- 2 Multiple field
- 3 Shift
- 4 Space
- 5 Backspace/delete button

Fig. 28-5 Keypad



Note

The use of the keypad is described here once. Later in the instruction manual, there is only a request to enter designations or names.

At the bottom left of the keypad is the shift key (Fig. 28-5 Pos. 3).

- The functions of this shift key are:
 - Upper case
 - Lower case
 - Special characters
 - Numbers
- These setting options allow individual designations (e.g. of the measurement place name).
- To **activate** the shift key, turn the rotary pushbutton until the shift key is highlighted in black.

➡ To **enter** designations (e.g. measurement place name), proceed as follows:

1. Press the rotary pushbutton - a keyboard field with individually selectable letters opens in the lower half of the display.
2. Turn the rotary pushbutton to navigate through the keyboard field. Letters with a blue background (Fig. 28-5 Pos. 2) have a multiple assignment. The assignment switches when the rotary pushbutton is pressed and held for approx. 1 second.
3. Press the rotary pushbutton until the desired letter is highlighted in black. The letter is transferred to the text field.
4. Repeat the procedure until the complete text (e.g. measurement place name) is stored in the display.

28.4 Input via Numeric field

In some parameters, dimensions or other numerical values can be entered. When selecting such a parameter, a numerical field opens in the lower part of the display (analogue to the keyboard field).



Note

The use of the numeric field is described here once. Later in the instruction manual, there is only a request to enter dimensions or numerical values.

- Press the rotary pushbutton - a numerical field appears.
 1. Enter the values digit by digit. The input is done in the same way as described for the keyboard field.
Pay attention to the use of decimal points in dimensions. The dimension (e.g. of the canal profiles) is specified in METER per default.
- To **enter further dimensions** (e.g. for a trapezoidal profile), after confirming (by pressing the rotary pushbutton), continue turning the rotary pushbutton until you reach the next possible dimension entry. Repeat the process as long as necessary.

28.5 Input Correction

- Incorrect entries are deleted letter by letter or digit by digit backwards with the backspace key:
 1. Open the keypad.
 2. Turn the rotary pushbutton until the >Back< arrow (back button) (Fig. 28-5 Pos. 5) is visible.
 3. Press the rotary pushbutton - the last incorrect letter or the last incorrect digit will be deleted. Repeat the process as often as necessary.
- Then continue writing until the correct designation or dimension is completely shown in the display, then confirm the entry with the right function key.
The designation or the numerical value is taken over by NivuFlow and shown in the display (e.g. for the measurement place name).

28.6 Menus

All menus are described in a logical programming sequence in Chapter "Parameterisation". Depending on the transmitter type, six to nine basic menus are available. The basic menus can be viewed and selected by pressing the right function key.

In detail these are:

Application or Names of Measurement Places	Guides commissioning personnel through the complete parameterisation of measurement place dimensions, sensor selection, analogue and digital inputs/outputs, controller function and diagnostics.
Data	<ul style="list-style-type: none"> • Graphical representation of the progression of flow rate, level, medium temperature and (average) flow velocity • Display and option to reset different flow totals • Storage of data, memory erasure • Saving and loading of parameters • Formatting the USB stick • Change in storage cycles and totals • Display of the daily and total transmitter operating hours as table
System	<ul style="list-style-type: none"> • Retrieval of basic information (serial number, version, item number, etc.) on the transmitter and the connected sensors (required for queries) • Setting language, time/date format and displayed/stored (measurement) units under >Country Setting< • Setting the system time and time zones under >Time/Date< • Error messages under >Error Messages< • Service levels, password changes, activation of optional functions, reset and restart of the measurement system
Communication	Setting parameters for all communication interfaces of the NivuFlow such as TCP/IP, web server, data transmissions, alarm messages as well as Modbus
Display	<ul style="list-style-type: none"> • Input of basic parameters such as backlighting, dimming of the display as well as (partial) definition of the type of display in the main display • Setting the output fields (text, decimal places, etc.)
Connections	<ul style="list-style-type: none"> • Activation of connection options for iXT Ex Separation Module or MPX Multiplexer • For Type M9/G9 (with multi measurement place function) assignment of: <ul style="list-style-type: none"> ▪ connection of the flow velocity sensors to the individual measurement places ▪ digital/analogue inputs and outputs to the measurement places

Tab. 9 Overview Basic Menus

Main Screen

Quick Access

In addition to displaying the values themselves, the main screen also allows for direct access to the most important setting parameters.

The quick access enables to directly jump to important individual menus without having to go through the (sub)menus of the parameterisation. It hence serves as quick and uncomplicated check of the individual sensors involved in the measurement.

Quick diagnosis, uncomplicated parameter adjustment and adjustment are possible by using the quick access. Direct queries for basic device data such as serial and article numbers as well as the firmware version of the transmitter and the connected sensors are also possible in just a few steps.

29 General Overview



Note on the Displays and Descriptions in the Manual

Depending on the equipment/transmitter type, the descriptions and display illustrations may differ from those shown in the instruction manual.

Multiple measurement places or a combi measurement place are available only with the NivuFlow 750 Type M9/G9. The same applies to the equipment of a regulator with NivuFlow 750 Type SR/GR or M9/G9. These illustrations and descriptions are not valid for the other transmitter types.

The following information is provided in the **top area** of the display:

- Measurement Place Name
- Date (alternatively 1, 2, 3, etc.; see Fig. 30-1)
- Time (alternatively 1, 2, 3, etc.; see Fig. 30-1)

The **red full circle with a white cross** in the top display area indicates pending errors in the system or individual sensors.

The **service key** in this area indicates that the password has been entered within the last six hours and that all further **parameter changes** can be saved **without** having to enter the **password** again. The six-hour period begins when the password is entered once and ends automatically.

If a number is also displayed directly next to the service key, the transmitter is in service mode. This is usually the case when a NIVUS service technician has access to the transmitter.

⇒ See also Chap. “37.1 Save Parameters” and “28.2 Using the Control Elements”.

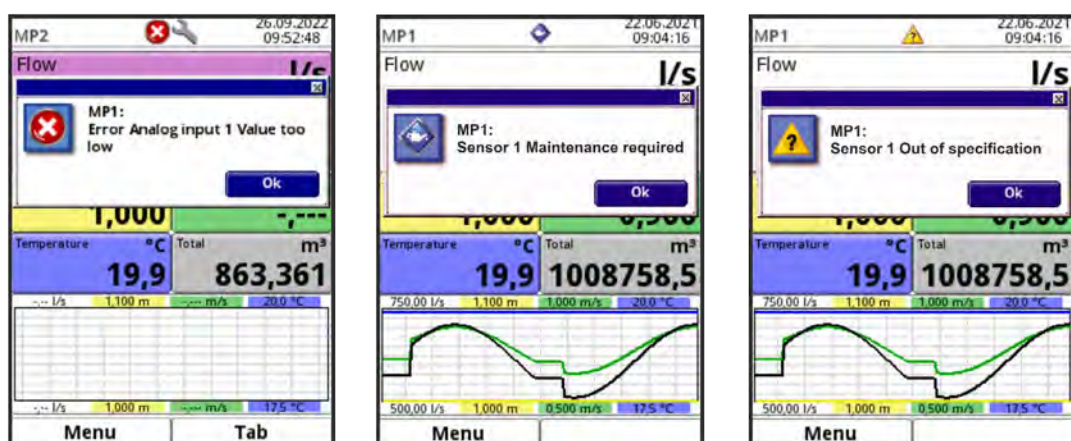

Fig. 29-1 Error and Maintenance Symbols

When sensor monitoring is activated, the **oil can** is displayed as soon as the measurement needs to be checked. This function can be activated (in the special NIVUS service level) by the NIVUS customer service as part of a maintenance contract.

The **yellow triangle with a question mark** is displayed when sensor monitoring is activated. The symbol indicates that the parameters of a flow velocity sensor are outside its technical specification and safe operation can no longer be guaranteed. This function can be activated (in the special NIVUS service level) by the NIVUS customer service as part of a maintenance contract.

In operation mode (with factory setting), the transmitter displays the following important measured values in the **main area**:

- Flow Rate
- Level
- Velocity (average calculated velocity)
- Medium Temperature
- Grand Total

The **bottom part** of the display shows a trend graph (hydrograph) and the assignment of the two control keys.

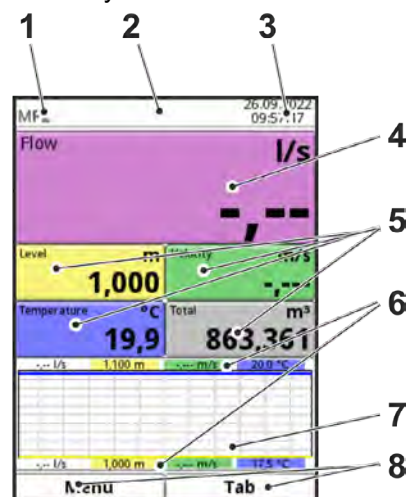

- 1 Measurement Place Name
- 2 Possible error message, system status information or display for active parameterisation or service mode
- 3 Date/Time
- 4 Display Area 1 (output field 1 for the flow rate)
- 5 Display Area 2 (output field 2...5 for level, wetted hydraulic area, analogue output X, medium temperature, air temperature, totals, daily average or, with the combi measurement place of the NF 750 Type M9/G9, for measurement place 1/2/3 and totaliser)
- 6 Automatic scaling for display area 3 (Pos. 7)
- 7 Display Area 3 (trend graph on level, velocity, medium temperature and flow rate)
- 8 Function displays for the assignment of the keys

Fig. 29-2 Main Screen Overview (with default settings)

With NivuFlow 750 Type M9/G9 the **main screen switches** back and forth between the active measuring points, provided that switching is activated under >Switch Main Screen< (see Chap. "44 Parameter Menu Display").

With Type M9/G9, it is possible to scroll **manually** between the individual measurement places using the **tab key**.

➤ **Direct access** to the most relevant settings and information:

1. Rotate the rotary pushbutton until the selected field is indicated black.
2. Press the rotary pushbutton: the dialogue window of the according section opens.

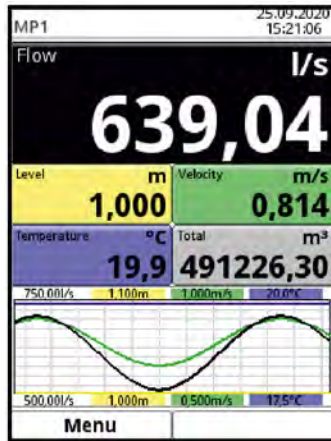

Fig. 29-3 Selected Screen Flow



Note

After changing system-specific parameters, the changes must be saved for them to take effect.

30 Display Field Flow

After activating the dialogue window by pressing the rotary pushbutton, the individual menus (Information, Diagnostics, Settings, Display and Error Messages) can be accessed via the pop-up menu (see Chapter “42.1 Information”, “Diagnostics”, “39.1 Setting the Measurement Place Parameters (Menu Application)”, “44 Parameter Menu Display” and “42.4 Error Messages”).

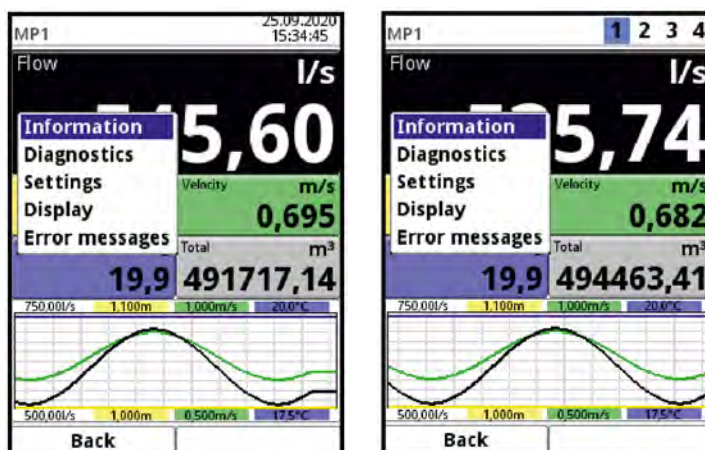

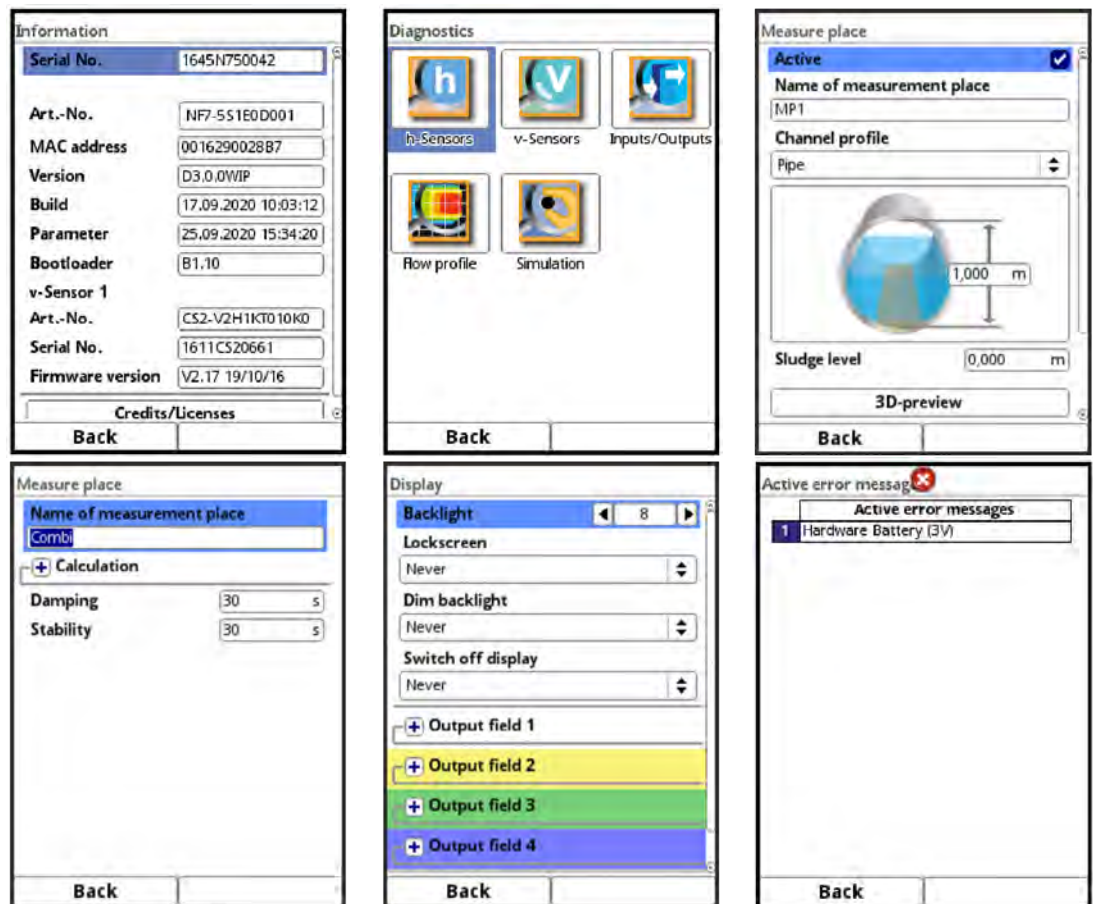
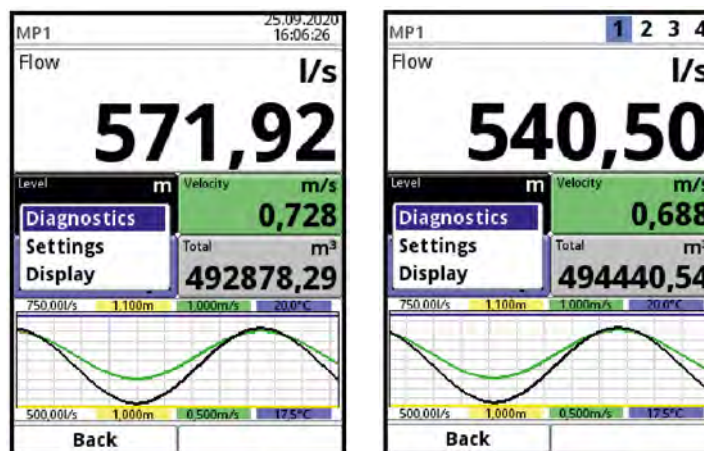

Fig. 30-1 Flow: Pop-Up-Menu and Menu Pages

31 Display Field Level (except combi measurement place NF 750 Type M9/G9)

After activating the dialogue window by pressing the rotary pushbutton, the individual menus (Diagnosis, Settings and Display) can be accessed via the pop-up menu (see Chapter “47 Diagnostics h-Sensors”, “39.2 Setting Parameters in Menu h-Sensors” and “44 Parameter Menu Display”).



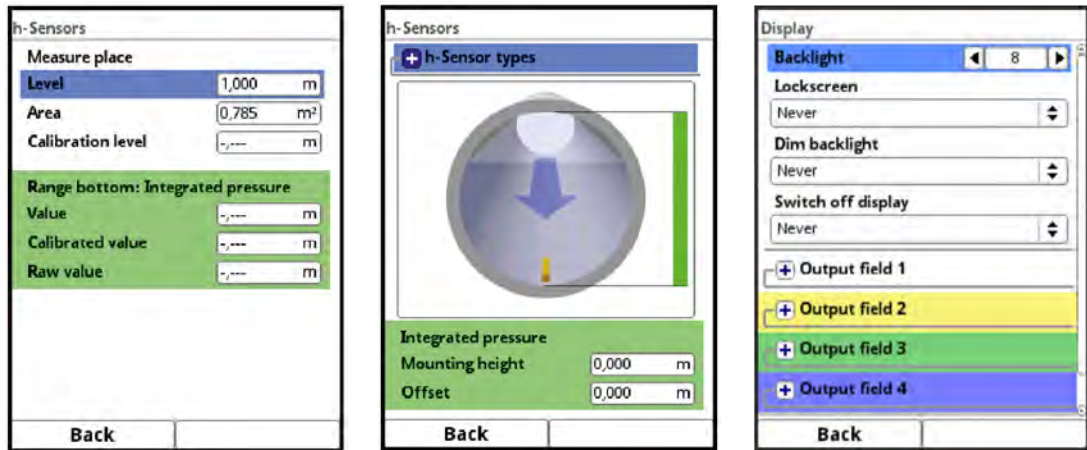

Fig. 31-1 Level: Pop-Up-Menu and Menu Pages

32 Display Field Velocity (except combi measurement place NF 750 Type M9/G9)

After activating the dialogue window by pressing the rotary pushbutton, the individual menus (Diagnosis, Settings and Display) can be accessed via the pop-up menu (see Chapter “48 Diagnostics v-Sensors”, “39.3 Setting Parameters in Menu v-Sensors” and “44 Parameter Menu Display”).

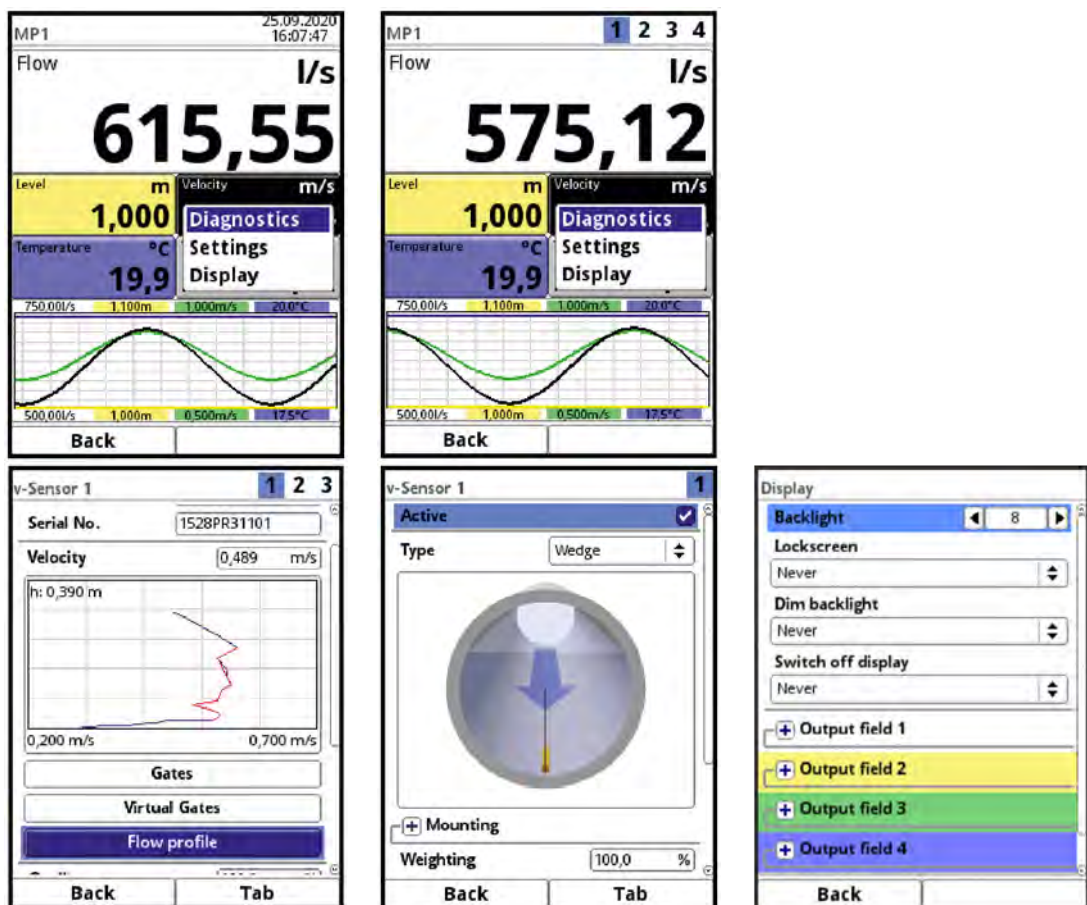

Fig. 32-1 Velocity: Pop-Up-Menu and Menu Pages

33 Display Field Temperature (except combi measurement place NF 750 Type M9/G9)

After activating the dialogue window by pressing the rotary pushbutton, the menu Display can be accessed via the pop-up menu (see Chapter “44 Parameter Menu Display”).

If several flow velocity sensors are connected, the **temperature sensor** of flow velocity sensor 1 is used. The temperature is read automatically and the value is displayed.

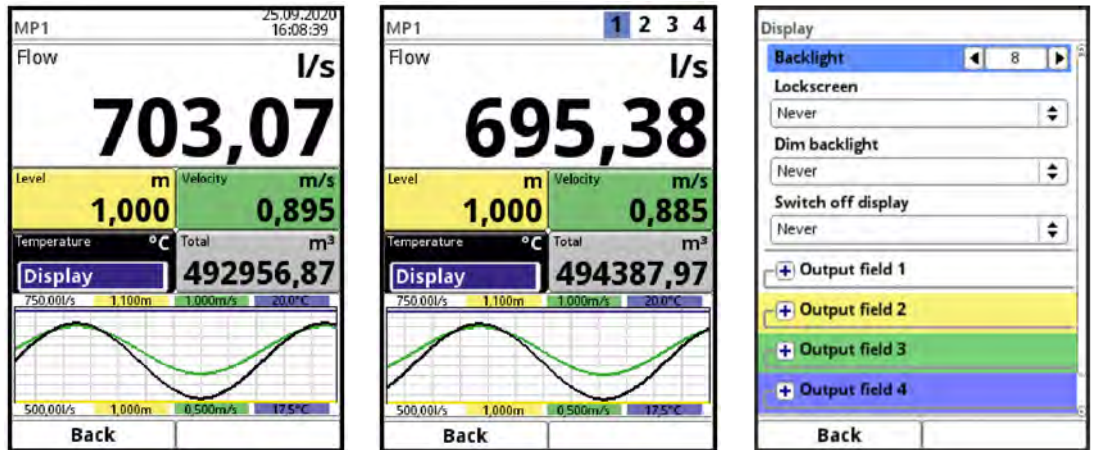

Fig. 33-1 Temperature: Pop-Up-Menu and Menu Page

34 Display Field Total

After activating the dialogue window by pressing the rotary pushbutton, the individual menus (Total, Daily Totals and Display) can be accessed via the pop-up menu (see Chapter “41.2 Total”, “41.3 Day Totals” and “44 Parameter Menu Display”).

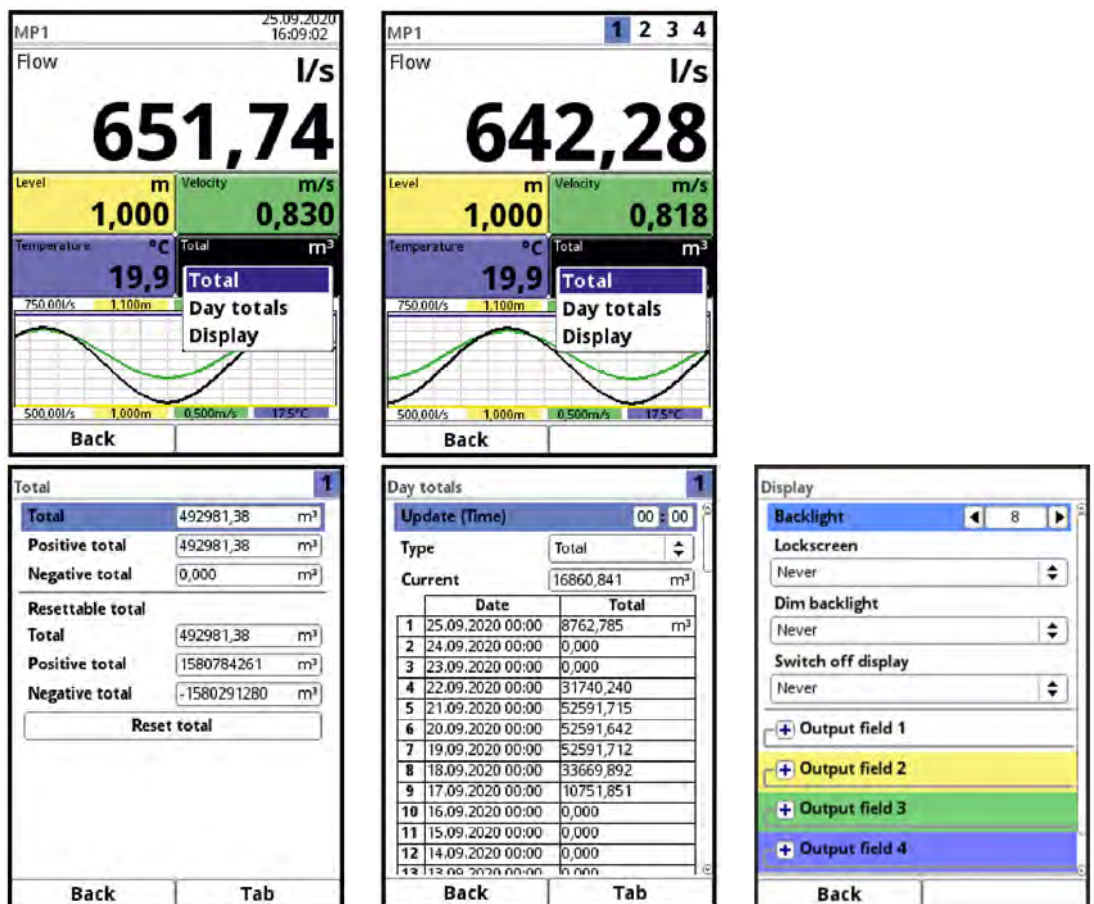

Fig. 34-1 Total: Pop-Up-Menu and Menu Pages

35 Display Field Trend/Hydrograph

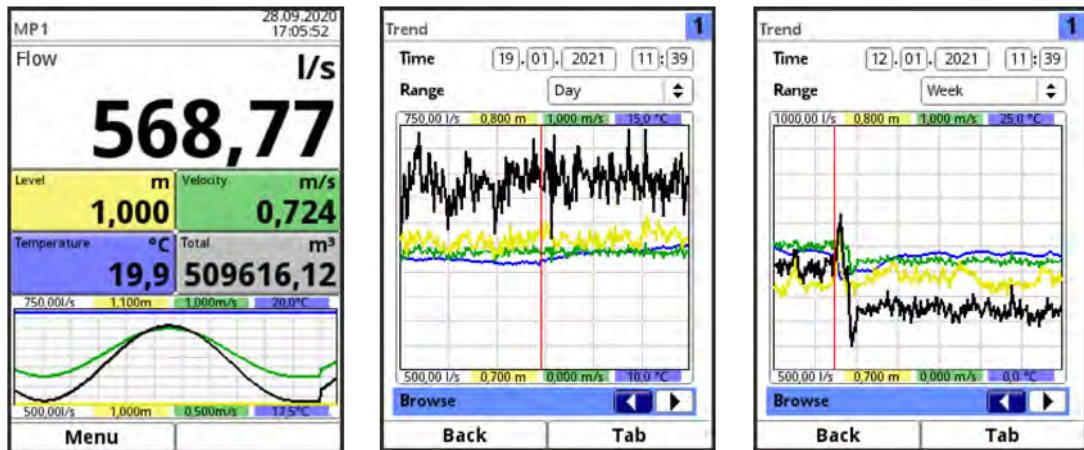

Fig. 35-1 Trend/Hydrograph: Pop-Up-Menu and Menu Pages

If a more detailed and extensive graphic display is required beyond the main display, the graphic field can be selected directly.

The display period and the display area are available for selection.

The displayed time period can be moved using the >Scroll< function (arrow keys below the diagram).

36 Display Field Measurement Place of Combi Measurement Place (with NF 750 Type M9/G9 with several Measurement Places)

All three windows for the individual measurement places have the same structure.

After activating the dialogue window by pressing the rotary pushbutton, the individual menus (Diagnostics, Settings, Display and Error Messages) can be accessed via the pop-up menu (see Chap. “Diagnostics”, “39.1 Setting the Measurement Place Parameters (Menu Application)”, “44 Parameter Menu Display” and “42.4 Error Messages”).



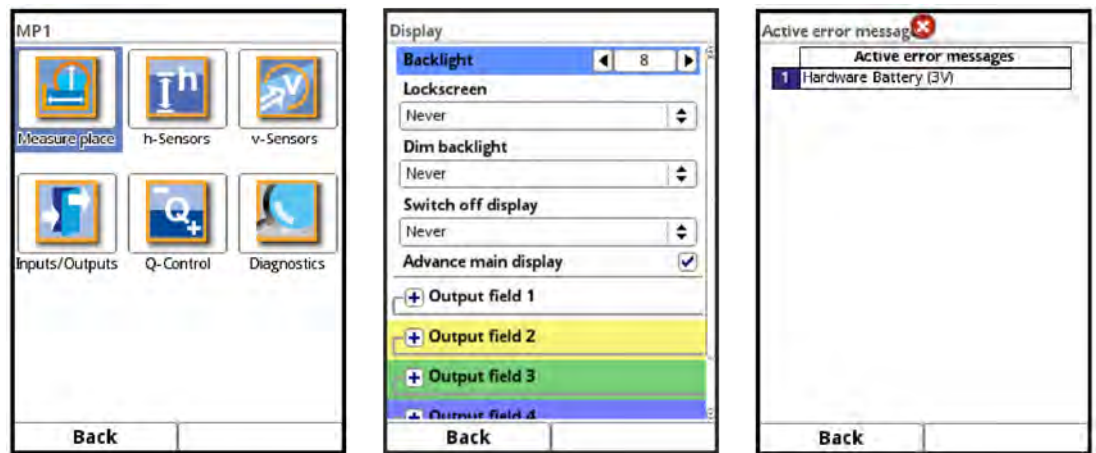

Fig. 36-1 Measurement Place (Combi): Pop-Up-Menu and Menu Pages

Setting Parameters

37 Basics

In principle, changed parameters do not become effective before they have been saved.

When leaving any menus, the transmitter checks whether parameters have been changed.

Finally, you will be asked whether you wish to save the parameters.

- >Yes<: The changed parameter setting is accepted and saved.
- >No<: The changes to the parameters are discarded and the transmitter exits the menus.
- >Cancel<: You exit the query, remain in the parameterisation and can continue with the adjustment of the parameters. The changed parameters are not yet effective and not saved.

37.1 Save Parameters

Enter a valid password to accept and save the parameters.

Default setting: 2718

The **service key** in the upper display area indicates that the password has been entered within the last six hours and that all further **parameter changes** can be saved **without** having to enter the **password** again. The six-hour period begins when the password is entered once and ends automatically.

This period and thus the possibility to unintentionally change parameters without password entry can be deliberately cancelled. To do this, select the >Service Level< under >System< / >Service<. When asked for the password, do **not** make an entry, but confirm the empty, untouched field with the right button >Enter<. The transmitter exits the mode with parameterisation without password entry.

If a number is displayed directly next to the service key, the transmitter is in service mode. This is usually the case when a NIVUS service technician has access to the transmitter.

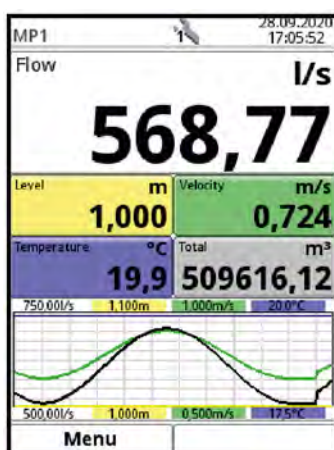

Fig. 37-1 Service Key - Service Mode

37.2 Change Password

➡ See also Chapter "42.5.2 Change (System) Password".

The default password can be changed at any time. Note that a changed password secures the changes to all transmitter settings. The input is limited to a maximum of ten characters.

➡ Procedure to change the password:

1. Open the >System< menu.
2. Select the >Service< submenu.
3. Activate the >Change Password< field.
4. Enter the existing password by using the numerical field.
5. Enter the new password (ten characters max).

The new password is accepted by the transmitter and saves all transmitter settings.



Important Notice

Only give the password to authorised persons!

If you write down the password, keep it in a safe place.

If the password is lost, contact the NIVUS hotline.

38 Parameter Functions

38.1 Main Menu

The transmitter is parameterised via the total of six or nine (only for NivuFlow 750 Type M9/ G9) setting menus on the first menu level. The individual menus and submenus are explained in greater detail starting with Chapter "39 Parameter Description".

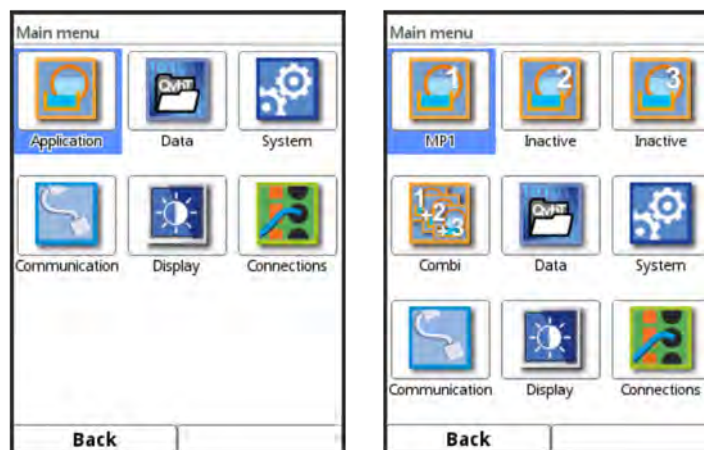

Fig. 38-1 Overview Main Menu

➡ When setting parameters observe Chapter "28 Principles of Operation".

38.2 Functions of the first Menu Level

38.2.1 Menu - Application

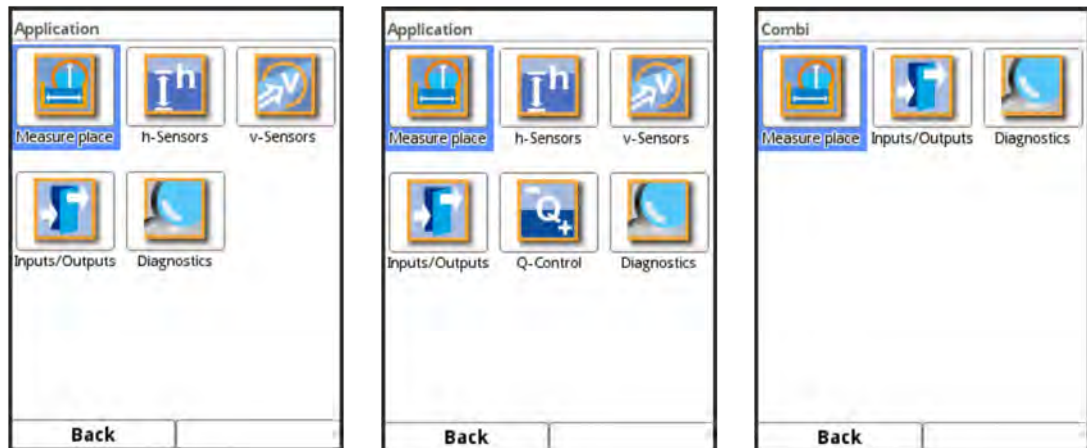

Fig. 38-2 Menu - Application

This menu is the most comprehensive and important within the parameterisation of the transmitter. The >Application< menu contains up to six submenus, depending on the device version/equipment. The shape and dimensions of the measurement place(s) are parameterised here. The level and flow velocity sensors used are defined and the data for their mounting position is parameterised.

You also define the required analogue and digital inputs and outputs here:

- Functions
- Measurement Ranges
- Measurement Spans
- Limit Values
- Error Messages
- Actuator Controls if required

The parameters of the flow controller (Q-Controller) are set under >Application<. The flow controller (Q-Controller) is available with NivuFlow 750 Types SR/GR/M3/G3/M9/G9.

In the >Application< menu there are diagnostic options available for:

- Sensors
- Inputs and outputs
- Overall system
- Flow profile (display of the measured flow velocity profile in different 3D views)
- Simulation (of velocities and inputs and outputs to verify the function of the overall system)



The diagnostic functions are explained in chapter "Diagnostics" starting at Page 187.

The following can be specified or changed in the >Application< menu:

- Constant, fixed sludge levels
- Low-flow suppression
- Damping of signal evaluation and output
- Stability of signal evaluation and output

38.2.2 Menu - Data

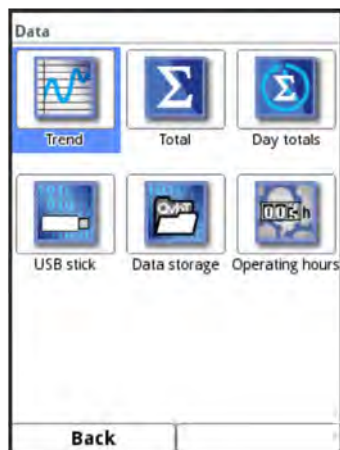

Fig. 38-3 Menu - Data

The >Data< menu allows access to all internally saved measurement values.

The following functions are available:

- Graphic representation of the measurement values
- Listing of the last 100 24h day totals and operating hours
- Listing of all totals (resettable and non-resettable positive, negative and grand totals)
- Communication and transmission options of internal files
- Loading and saving parameters
- Formatting the external USB stick
- Transfer of set parameters from and to USB stick
- Setting and deleting options of the internal data memory
- Setting the storage cycle

38.2.3 Menu - System

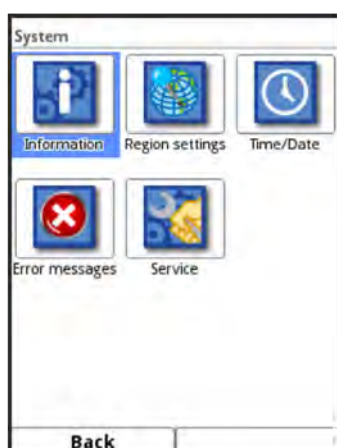

Fig. 38-4 Menu - System

The >System< menu contains information on the transmitter:

- Article Number
- Firmware Version
- Serial number

- MAC Address
- Information about Open Source Software used in the device firmware (Credits/Licences)

In addition, the following settings/corrections are possible:

- Set Language
- Set units (for measurements or storage, unit system, decimal separator)
- Set/correct date and time (system time, time zone, time server)
- Read active messages
- Delete error memory
- Change Password
- Restart (system or measurement)
- Parameter Reset
- Update of transmitters and sensors (in service level; only in consultation with NIVUS)

38.2.4 Menu - Communication

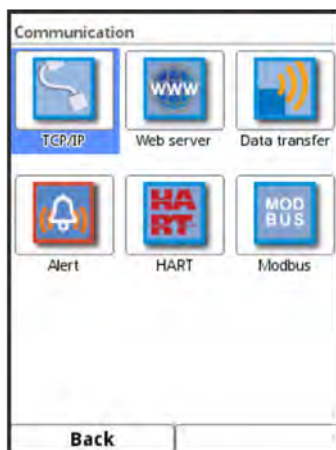

Fig. 38-5 Menu - Communication

This menu includes the setting options of various communication interfaces with other communication systems:

- TCP/IP
- Web Server
- Data Transmission
- Message Alarm Settings
- HART
- Modbus

38.2.5 Menu - Display

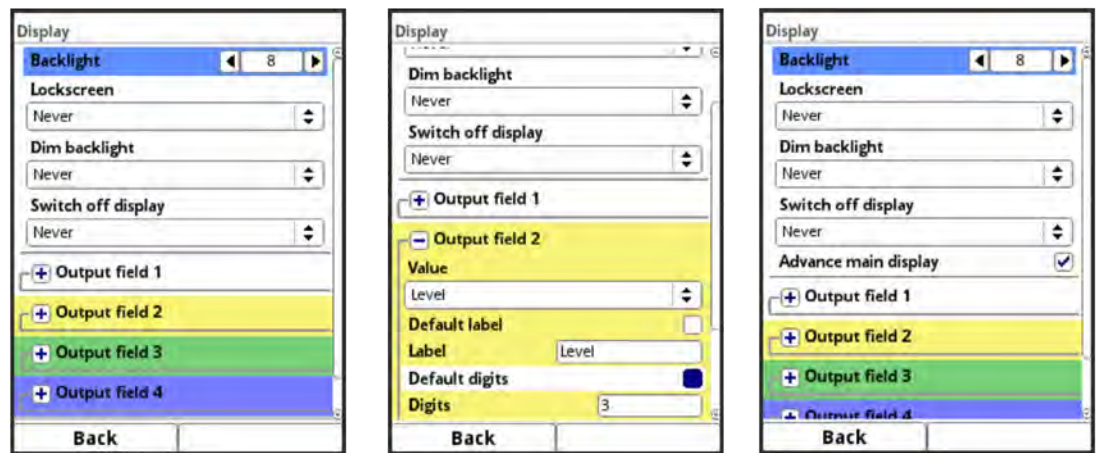

Fig. 38-6 Menu - Display

In this menu, adjustments are made to the background lighting, any corrections to the five output fields of the main display are set if necessary, and (de)activation of the main display (for multiple measuring points with NivuFlow 750 Type M9/G9) is set.

38.2.6 Menu - Connections

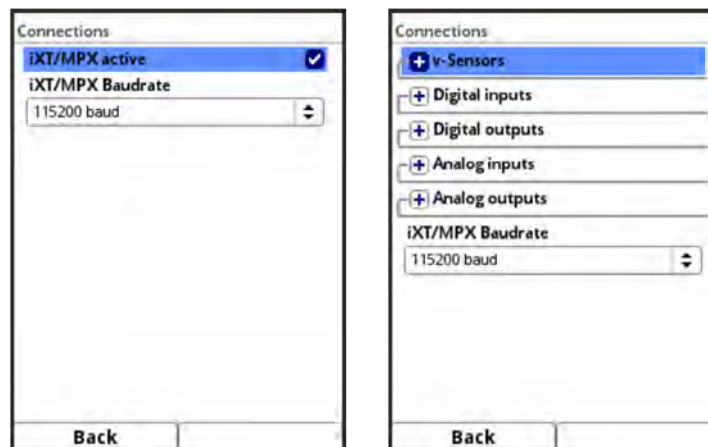

Fig. 38-7 Menu - Connections

The connection of an intelligent iXT Ex Separation Module or a multiplexer to the transmitter must be entered here.

In addition, for the NivuFlow 750 type M9/G9 with multiple measurement places, the connections of the sensors and the inputs/outputs are selected and assigned to the individual measurement places.

39 Parameter Description

39.1 Setting the Measurement Place Parameters (Menu Application)

The submenu >Measurement Place< is one of the most important basic menus in the parameterisation.

The parameter settings of the measurement place include basic settings:

- Measurement Place Name
- Type and dimensions of the channel profile
- Possibly fixed settings for sediments

- Low-flow suppression
- Damping and stability of the measurement
- With the NivuFlow 750 Type M9/G9, several measurement places can optionally be created and individually set active/inactive.

39.1.1 Active/Activation of Measurement Places (only for NivuFlow 750 Type M9/G9 with multiple measurement places)

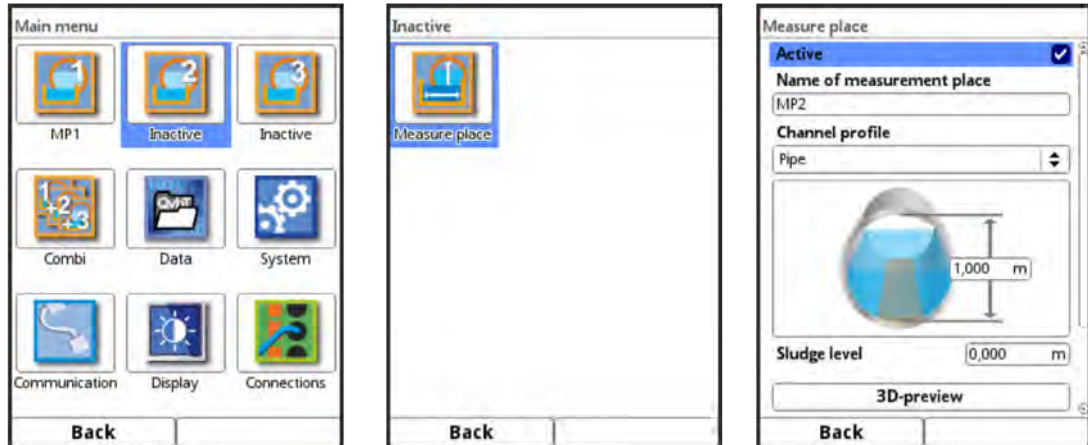

Fig. 39-1 Measurement Place inactive/active

This option is only available with NivuFlow 750 Type M9/G9 (with multiple measurement places), as it is directly related to the transmitter's capability to handle multiple measurement places.

Checking the box activates measurement place 2/3. If the box is not checked, the measuring point is inactive, nothing is displayed and its parameters cannot be set.

39.1.2 Measurement Place Name

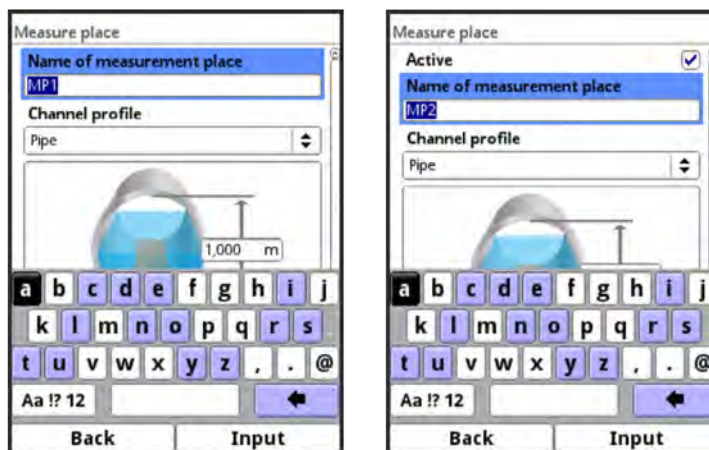

Fig. 39-2 Specifying the Name of the Measurement Place

The desired measurement place name is entered here. The input is limited to 256 characters.

Default setting of the measurement place name: MP1

When resetting the measurement place name, the default name is automatically deleted after the first letter or number is selected.

🔄 Procedure:

1. Use the keypad to enter the measurement place name completely into the text field (see Chap. "28.3 Input via Keypad").

2. Confirm the measurement place name with the right function key "Input".
The measurement place name is transferred to the main menu and displayed there.

39.1.3 Channel Profiles

The transmitter allows the selection of a variety of standardised channel profiles that are predominantly used in practice.

Since older sewer systems in particular often have special designs, the transmitter also offers the option of entering symmetrical and asymmetrical flumes in their dimensions or height/area in the form of a table.

The selected profile is displayed graphically when the 3D preview field is selected. The entered measurements are set in relation to each other in the graphical representation.

This visual check can immediately determine whether the profile has been laid out correctly in principle. Especially with free profiles, this direct control is helpful.



Fig. 39-3 Selectable Channel Profiles

- ➡ Select from the available channel profiles:
 - Pipe
 - Ellipse
 - Egg Profile (1:1.5)
 - Rectangle
 - U-Profile
 - Trapezoid
 - Water Bed
 - Height-Width (symmetric)
 - Height-Width (asymmetric)
 - Height-Area
 - $Q=f(h)$
- ➡ After selecting the profile, enter the values of the dimensions digit by digit. Pay attention to the unit of measurement (decimal point).
Default setting: channel profile dimensions in METER.

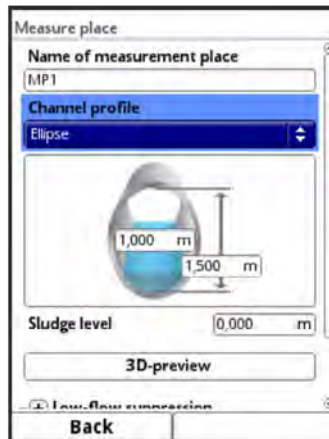

Fig. 39-4 Example of a channel profile menu

Pipe

This selected shape is suitable for round pipes. This shape selection can also be used for half shells with a maximum filling level of 50 %.

Deformed pipes with asymmetrical height/width ratio can be parameterised via the channel profiles Ellipse or Height-Width (sym.) or Height-Width (asym.).

A separate profile selection is created for U-profiles.

Ellipse

The elliptical profile is mainly used for pipes subject to high mechanical loads (lateral pressure or crest pressure). Special channel shapes are also known as elliptical profiles.



Ellipse Profile or Egg Profile

Do not confuse the horizontally and vertically symmetrical ellipse profile with the egg profile. Egg profiles have different radii in bottom and crest and are therefore only vertically symmetrical.

- ➡ Enter both dimensions of the elliptical profile.

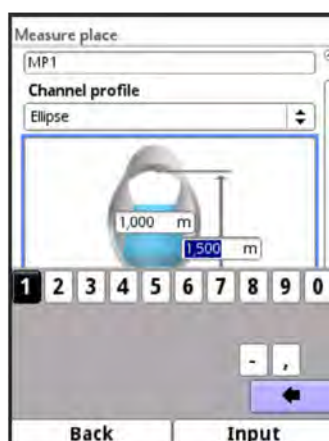

Fig. 39-5 Setting Parameters for the Elliptical Profile

Egg Profile (1:1.5)

This channel is a "standard egg" according to DWA A 110 with a width/height ratio of 1:1.5. Pressed or compressed egg profiles must be parameterised using a free profile.

When setting the parameters for a "standard egg" egg profile, only the maximum channel width is entered. The transmitter automatically calculates the height using the specified 1:1.5 ratio.

Rectangle

With this profile selection, channels with vertical walls and horizontal bottom are parameterised. By simply entering the channel width and height, the parameters are quickly set.

This menu also includes the option to set parameters for a channel with a central dry weather flume in semicircular or U-profile form.

- **Rectangle with Dry Weather Flume**

➡ Procedure:

1. Select dry weather flume.
2. Check the >Active< box.
Two more input fields open up.
3. Enter height and diameter of the dry weather flume.
4. Check the input of the dimensions using the 3D display.

U-Profile

The U-profile consists of a semicircle at the bottom and vertical walls. The semicircle radius here is 0.5x the channel width. It is entered independently by the system in the calculation.

For profiles with radii > 0.5x the channel width use the free profile option.

Trapezoid

With this profile selection, it is possible to parameterise symmetrical channels with a horizontal bottom and sloping side walls.

Symmetrical channels with a horizontal bottom, sloping side walls and attached vertical walls are also parameterised via this profile setting.

Trapezoidal profiles with sloping base must be parameterised via the "free asymmetric profile with height-width" (see Page 99).

This menu also includes the option to set parameters for a channel with a central dry weather flume in semicircular or U-profile form.



Fig. 39-6 Setting Parameters for the Trapezoidal Profile

- **Trapeze with Dry Weather Flume**

➡ Proceed as described in the rectangle with dry weather flume section on Page 97.

Water Bed



Extensive expertise required

The parameterisation of a water bed requires extensive knowledge and experience with the functions of the NivuFlow 750/700 as well as the hydrological boundary conditions.

We recommend that the parameterisation be carried out by the NIVUS commissioning service or a specialist company authorised by NIVUS.

This type of channel is mainly used for applications in near-natural channels with rainwater or greywater.

With this profile, you define the reference point/zero point yourself. Usually, the maximum filling level or the water surface on a bank or channel side is defined as the zero point. Here, the watercourse profile for a specific watercourse section can be stored in the transmitter by means of local measurements.

- Enter the freely defined measurement sections in height and width, referred to the defined zero point, one after the other into the table.

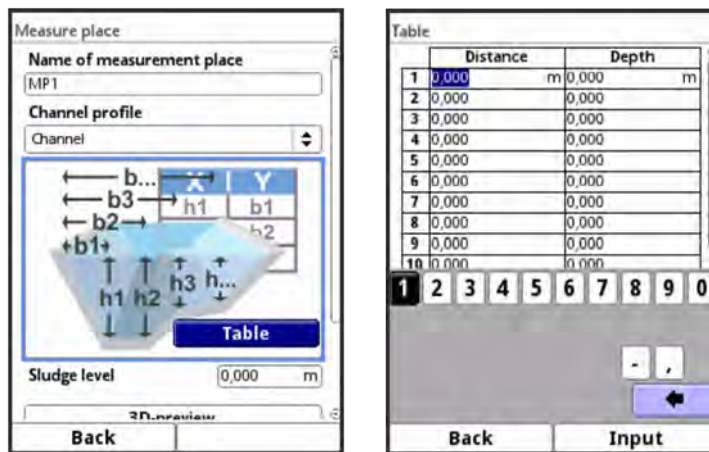

Fig. 39-7 Setting Parameters for the Water Bed Profile

Symmetrical profile with Height-Width (Height-Width (sym.))

Any symmetrical profiles can be set in this menu.

After selecting >Table< a table of values appears. A maximum of 32 breakpoint pairs (channel height/channel width) can be entered in this table. These values are automatically calculated in the system and stored internally as a symmetrical profile.

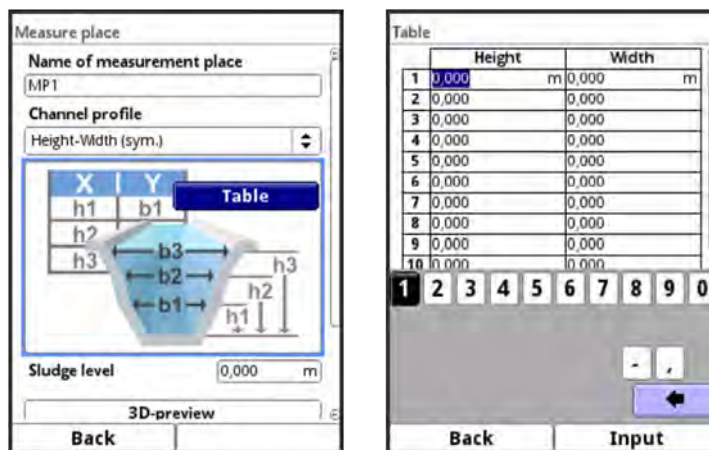

Fig. 39-8 Setting Parameters for the Height-Width (sym.) Profile



Drawing required

A drawing to scale or a dimensioned sketch is required for the parameterisation of the channel.

➤ Procedure:

1. Draw a vertical guide line in the centre of the channel on the scaled drawing.
2. Draw horizontal guide lines at the prominent profile change points.
3. Measure the length of these guide lines and then convert them to scale.
4. Start at height "0" to define a channel start.
5. Enter all other breakpoints "free" in height and width.

The distance between the individual height points can be variable. For the profile definition, it is not necessary to specify all 32 breakpoints. The transmitter line-arises between the individual breakpoints.

In the case of large uneven changes in the channel dimensions, select a smaller breakpoint distance in this change range.

After the channel parameterisation has been completed, the entered values are displayed graphically in proportion to each other.
6. Check the input of the dimensions using the 3D display. This visual control option makes any gross parameterisation errors visible.

Free asymmetric Profile with Height-Width (Height-Width (asym.))

In practice, asymmetrical profiles occasionally appear in unusual shapes. The parameterisation option for asymmetric profiles is used for this.



Important note on the viewing direction for free profiles

The viewing direction >Width left< or >Width right< is opposite to the flow direction in the channel (see step 4 on Page 100).

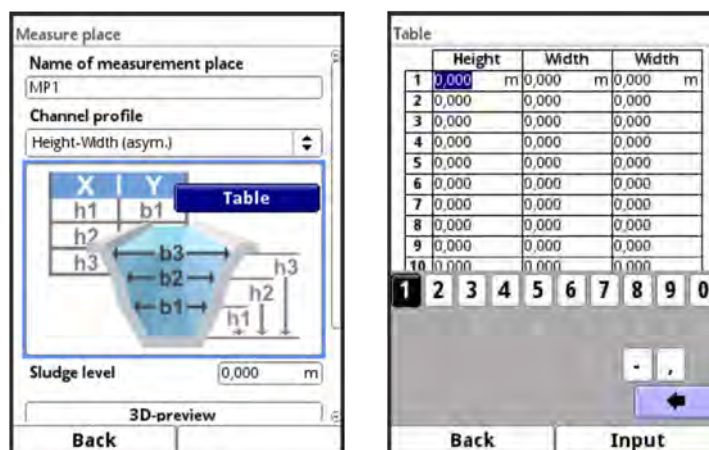

Fig. 39-9 Setting Parameters for the Height-Width (asym.) Profile



Drawing required

A drawing to scale or a dimensioned sketch is required for the parameterisation of the channel.

➤ Procedure:

1. Draw a vertical guide from the lowest channel point upwards on the scaled drawing.
2. From this guide line, draw horizontal guides to the left and right at the prominent profile change points.
3. Measure the distances of these guide lines from the centre guide line to the right and left respectively.
4. Enter the breakpoints, converted to scale, in the 3-column value table as follows:
Height / Width to the left / Width to the right.
Here, **observe** the previously mentioned important note on the **viewing direction** for free profiles on Page 99.
5. Start at height "0" to define a channel start.
6. Enter all other breakpoints "freely". A maximum of 32 breakpoints can be specified. The distance between the individual height points can be variable. For the profile definition, it is not necessary to specify all 32 breakpoints. The transmitter linearises between the individual breakpoints.
In the case of large uneven changes in the channel dimensions, select a smaller breakpoint distance in this change range.
After the channel parameterisation has been completed, the entered values are displayed graphically in proportion to each other.
7. Check the input of the dimensions using the 3D display. This visual control option makes any gross parameterisation errors visible.

Free symmetrical profile with Height-Area (Height-Area)

Some hydraulic tables contain the value pairs Height-Area instead of Height-Width for symmetrical channels. In this case, enter the value pairs in the selected Height-Area table.

The rest of the procedure is identical to the parameterisation of the Height-Width profile. Only a graphic representation of the parameterised profile is not possible here.

Q/h-Function ($Q=f(h)$)

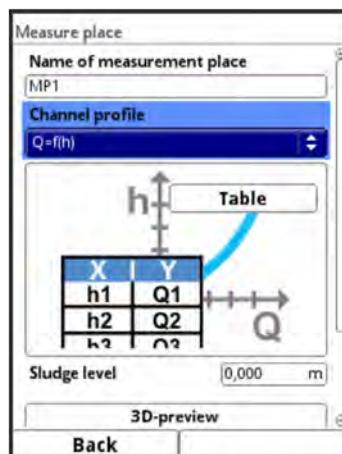

Fig. 39-10 Q/h-Function

This function differs significantly from the previously described channel profiles. When selected, neither the channel profile nor the flow velocity are taken into account. **Communication** with any connected flow velocity sensors is **switched off**. Therefore, the missing flow velocity value is not taken into account in any error diagnosis.

The system operates a pure Q/h function. This means that a defined flow rate value is displayed depending on the currently measured level. This value to be displayed is entered height-related in a value table.

A maximum of 32 height-related breakpoints can be specified in this table. The transmitter linearises between the individual breakpoints.

39.1.4 Sludge Level

In horizontal pipes and channels, depending on the measured medium, dirt load, grain size and flow velocity, deposits (sediments) may occur at the bottom.

In this parameter, a fixed sediment height (deposition) can be entered as >Sludge Level<. The entered sludge level is calculated as the "non-moving, bottom lying partial area of the channel with a horizontal surface". This height is subtracted from the total wetted hydraulic area before the flow calculation.

39.1.5 3D Preview

If the 3D preview is selected, the shape and dimensions of the parameterised measurement place with the respective sensors can be displayed with matching relations (depending on the accuracy of the parameter settings).

This function allows an immediate visual check of the plausibility of the parameterised geometry when setting the parameters of complex profiles, free profiles and water beds etc.

39.1.6 Low-flow suppression

This parameter is used to suppress the slightest movements or apparent quantities. The main field of application for this parameter is the measurement of flow rates in structures that are permanently dammed from the receiving water.

- ➡ Check the >Active< box.
Another input option opens. Enter here which absolute value is to be suppressed, e.g. for lowest discharge rates. It is not possible to specify negative values.

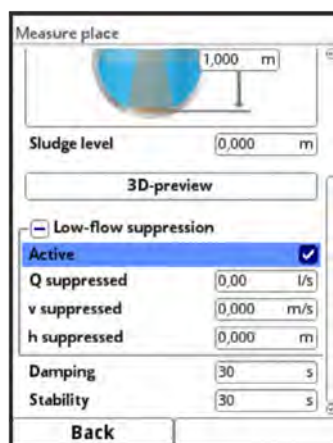

Fig. 39-11 Low-flow suppression

Low-flow suppression prevents the detection of the slightest changes in velocity. These changes can cause large apparent fluctuations in the measured volume over a longer period of time.

Application Example:

Slashing movement of a river into which a permanently dammed overflow channel flows.

Flow velocities that are smaller than this parameterised value are "suppressed". This means that no quantity is recorded and the transmitter does not store a value.

>Q suppressed<

- ➡ Specify the flow value to be suppressed. It is not possible to specify negative values. The entered value is interpreted as an absolute value and has both a positive and negative effect.

If the current, calculated measurement values are smaller than this entered value, the system automatically sets the measurement values to "0".

>v suppressed<

Low-flow volumes can be suppressed here for applications in large profiles and with high filling levels. The slightest changes in velocity can cause large apparent changes in volume over a longer period of time, which cannot be suppressed using the value >Q suppressed<. If the flow velocities are lower than this parameterised value, the system automatically sets the measurement values to "0".

This also makes the calculated volume "0".

Only a positive value can be specified. The entered value is interpreted as an absolute value and is effective for both positive and negative velocities.

>h suppressed<

Lower limit values for fill levels can be entered here. If the real levels are smaller than this entered value, the system automatically sets the measurement values to "0". This means that no area is calculated and no volume calculation can be carried out.

Instructions for use:

This parameter is mainly used when working with a pressure measuring cell in the lower level measuring range up to around 0 and the volume is simultaneously recorded in the last centimetres of the application using a Q/h relation. Pressure probes tend to zero point drift. Applications with completely empty channels could thus calculate a very low flow rate due to the low 0-point drift and the parameterised Q/h relation, which is reflected in an incorrect total flow rate over a longer period of time.

39.1.7 Damping

This menu point allows you to change the damping of the display and analogue output in seconds.

The damping refers to all level and flow velocity values that are available as input values. Individual values cannot be selected and damped differently.

All measurement values are stored over the specified time range and a moving average is calculated for each individual measurement value. This average value is used for further calculation of the flow rate.

The time range is entered in steps of 1 second.

Default setting: 30 s

39.1.8 Stability

The stability is the time in which the transmitter without valid (i.e. invalid) level and/or flow velocity values still displays a measurement value.

In this case, invalid means "not plausible" or "illogical". This evaluation is carried out by the flow velocity sensors POA, CS2 and EBM and the water ultrasonic level sensor integrated in the POA or CS2 as well as by the air ultrasonic sensor OCL and passed on to the transmitter as invalid. If the transmitter detects this invalid information, it operates with the last valid measured value for the parameterised stability time.

If the specified time is exceeded without a correct value being recorded, the transmitter goes to the measured value "0", taking into account the set damping.

Instructions for use:

This parameter is used

- *in applications with a turbulent and wavy water surface and the use of a water-ultrasonic or a type OCL air-ultrasonic sensor:*

Here, a temporary reflection of the ultrasonic signal can occur; i.e. the ultrasonic signal is deflected by a wavy water surface so that the reflected signal does not return to the sensor.

- *in applications with very few reflective particles (scatterers) in the medium: These can make the evaluation of the flow velocity difficult due to many invalid velocity measurements and cause an intermittent 0 display of the velocity.*

The time range is entered in steps of 1 second.

Default setting: 30 s



Note on Stability

Extended stability makes the measurement less sensitive to short-term disturbances.



Note on Sensor Errors

Sensor errors such as falling below the 4 mA limit with 2-wire sensors or a cable break with flow velocity sensors are output immediately without delay.

39.2 Setting Parameters in Menu h-Sensors

After setting the measurement place parameters, the level sensor(s) used must be defined and their operating ranges set in the submenu >h-sensors<.

39.2.1 h-Sensor Types



Fig. 39-12 Selecting the h-Sensor Types

A selection of level sensors can be found in the >h-Sensor Types< field.

➡ Open the >h-Sensor Types< parameter.

➡ Select the sensor type(s) connected to the transmitter.

In the vast majority of applications, it is sufficient to select a level sensor. When using several level sensors (e.g. i-Sensor and 2-wire level), set a tick for each sensor.

Info:

The number and types of level sensors required are determined when planning the measurement place. For example, it may be physically necessary to detect low and medium levels with the required high accuracy using an air-ultrasonic sensor. In case of full filling and when the air-ultrasonic sensor is flooded, the measurement then switches to pressure measurement.

Note:

Before parameterisation, get information about the planned level measurements and the required working ranges of the different sensors in the application.



Sensor connected?

A selected sensor that is not physically connected cannot be recognised/detected by the transmitter.

After completing the parameterisation, the transmitter detects the missing or incorrectly selected sensor and issues an error message.

The number of selected sensors corresponds to the number of individual level measurement ranges over the entire measurement cross-section. Only one level sensor per measurement can provide the valid value for the measurement. Incorrect combinations and combinations that do not make sense are not accepted by the transmitter.

A maximum of three different level sensors can be selected.

The sensor measurement ranges can be set below the channel graphic.



Transmitter does not recognise which type of sensor the 2-wire level sensor is

The representation of the sensor in the display is not decisive for the measurement range. As standard, the transmitter displays the 2-wire level sensor as an ultrasonic sensor from above.

Example

Air ultrasound sensor at the top with sound direction downwards; pressure sensor and water ultrasound on the bottom of the channel.

The level sensors are displayed in the channel shape that was previously parameterised under the measurement place.

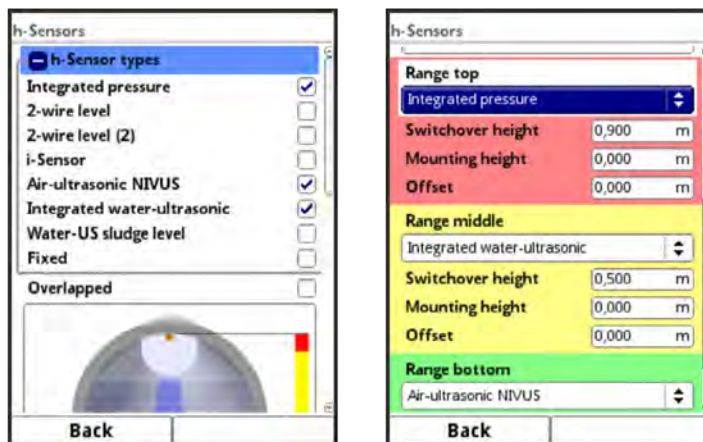

Fig. 39-13 Selecting the Level Sensors

The following level sensors are available:

- Integrated Pressure**
 The level is measured from below using a combi sensor with integrated pressure measurement cell (Type VxD or VxU).
 Side mounting, e.g. in case of sedimentation or high dirt load, is possible.
 The Level measurement in overflow conditions is possible too.
- Integrated Pressure (2) / (3)**
 Second and third combi sensor with integrated pressure measurement cell available.
- 2-wire Level**
 The level is measured via an external 2-wire sensor which is supplied by the transmitter.
Example: pressure probe Type NivuBar Plus or compact echo sounder Type NivuCompact.
 The use of a 0/4...20 mA signal from an external transmitter such as NivuMaster is also activated via this selection.

- **2-wire Level (2)**
Second external 2-wire sensor available.
- **i-Sensor**
Connection of the NIVUS i-Series ultrasonic sensor is made via analogue input AI1 using HART.
- **Air-Ultrasonic NIVUS**
The level is measured from above via an air-ultrasonic sensor Type OCL or DSM. These sensors are used for the measurement of low levels. The level sensor must be installed exactly in the middle of the channel crown, ($\pm 2^\circ$) parallel to the water surface.
- **Integrated Water-Ultrasonic**
The level is measured from below using a combi sensor Type POA-VxH, POA-VxU, CS2-VxH or CS2-VxU by water ultrasound. This sensor type is used to detect the discharges in the medium part filled area. The combi sensor must be installed exactly in the centre of the channel bottom ($\pm 2^\circ$). If there is a risk of sedimentation or sludge deposits, the sensor can be placed off-centre. In this case, this must be taken into account when defining the measurement ranges (see also Chap. "39.2.2 Definition of Measurement Ranges").
Select a different level sensor (ultrasound from above or pressure measurement cell) if necessary.
- **Water-US Sludge Level**
The water-US sludge level sensor is only listed in the selection if the >Float< was previously selected in the >v-Sensors< menu.
With this sensor, sedimentation levels can be determined if the measurement technology is suitable. This selection is only possible in combination with another height measurement for partial filling or for full filling (i-Sensor, 2-wire sensor or NIVUS air-Ultrasonic sensor).
A combi sensor Type POA-VxH or CS2-VxH with water ultrasound **from above** is used for this purpose.
This combi sensor is either permanently installed (e.g. for full filling via fixed setting) or attached via a float for partial filling.
See also Fig. 39-13.
- **Fixed Value**
This selection is intended for permanently full pipes and channels. No level measurement is required for these applications. The constant level is given to the measurement system and used for flow calculation.
This parameter can also be used as a support for the initial commissioning or for tests without an available level value.

39.2.2 Definition of Measurement Ranges

Depending on the type and number of selected sensors, a vertical coloured bar appears on the right side of the displayed channel profile. With this bar, the working range of the individual sensors is marked in the corresponding colour section.

- Measurement Range
 - Top: red
 - Centre: yellow
 - Bottom: green
- Number of sensors used
 - only one: solid green bar
 - two: colour combination green/red
 - three: colour combination green/yellow/red

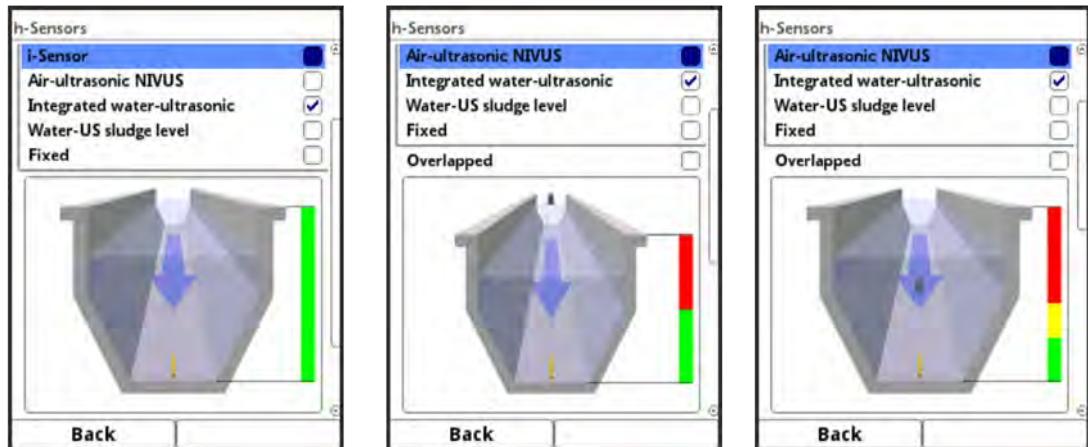

Fig. 39-14 Selecting Sensors and Display of Sensor measurement Ranges

Depending on the type and number of selected sensors, one to three coloured parameterisation areas are displayed below the channel display. The colour of these parameterisation areas corresponds to the colour of the vertical bar (as described before) and the assigned sensors.

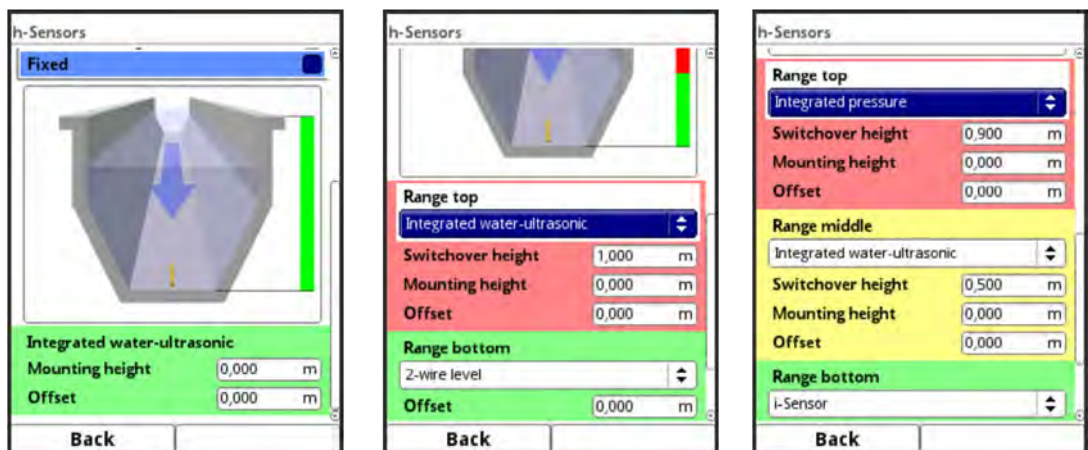

Fig. 39-15 Representation of the Parameterisation Ranges

The transmitter automatically assigns the sensors to the appropriate parameterisation range. The assignment depends on the parameterised channel shape.

- Air-Ultrasonic: measurement range bottom
- Pressure Measurement Cell: measurement range top
- etc.

This assignment can be changed as desired. When selecting the assignment, only those sensors are displayed that were previously selected (see Fig. 39-13).

A level sensor can also be used for two or three parameterisation ranges. In this case, the other activated level measurement values are only stored internally but are not used for calculation.



Fig. 39-16 Assignment Level Sensor to Parameterisation Range

Each parameterisation range can be changed in its range size. Make this change of range by changing the according >Switchover Height<.



Important Notice

Make sure that the values of the positioning of the individual sensors must be specified precisely.

Sensors with integrated pressure measurement cell must be placed at the lowest point of the channel bottom (sensor Types POA-VxD, POA-VxU, CS2-VxD, CS2-VxU and CSM-V1D).

For sensors that are mounted on an elevation (block or similar) or on a berm, a value other than "0" must be entered for the mounting height. Measure the distance from the **lower edge** of the sensor mounting plate to the lowest point of the application and enter this value as "Mounting Height".

For sensors mounted at an angle (e.g. when mounted laterally in a pipe or trapezoidal channel), the **centre** of the sensor mounting plate is the reference value.



For Combi Sensors observe:

The mounting height of the sensor is automatically adopted for the flow velocity sensor in the case of combi sensors (see Chap. "39.3.5 v-Determination low Levels").

An additional offset can be entered to adjust the pressure sensors.

Enter values by using the displayed keypad (according to Chapter "28.3 Input via Keypad").

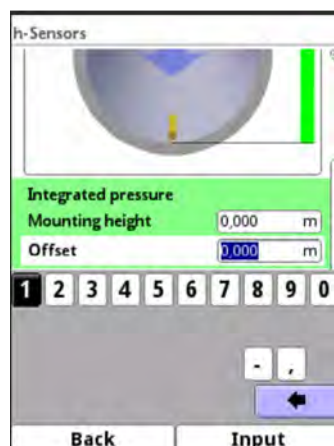

Fig. 39-17 Setting Parameters of the integrated Pressure Sensor

The same specifications apply to **flow velocity sensors with integrated water-ultrasonic sensor**.

- ☞ Check the iXT box in the i-Sensor selection menu if the i-Sensor is connected via the HART interface of an iXT.

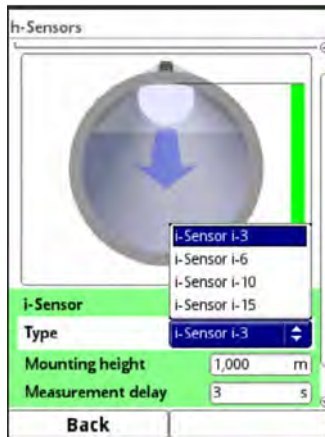

Fig. 39-18 Setting Parameters i-Sensor-Type



Activate iXT previously

If the i-Sensor is connected via an Ex Separation Module Type iXT, the use of an iXT must be activated in >Main Menu< / >Connections< before setting the sensor type parameters. Without activation, the selection of the connection in the >h-Sensors< menu is not visible.

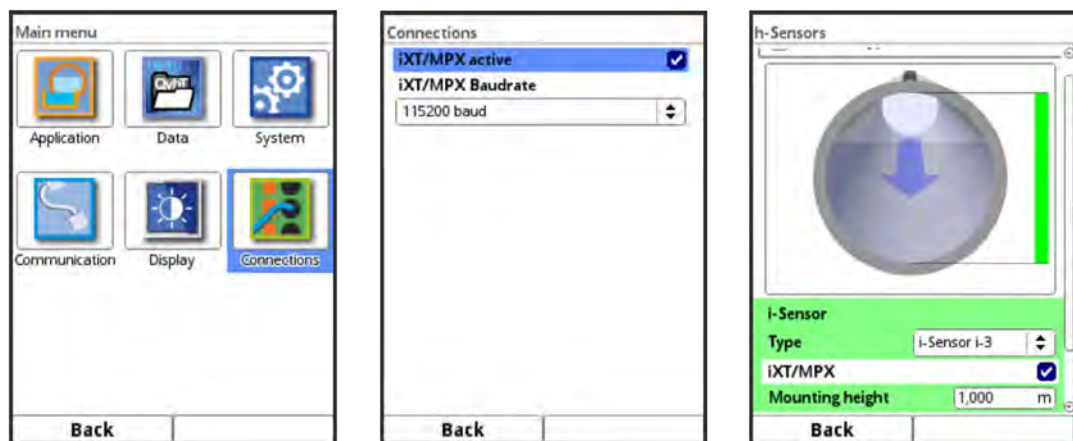

Fig. 39-19 Activating the Interface to connect the iXT

The specification of the mounting height of the i-sensor refers to the lower edge of the sensor to the zero point of the channel. This value defines the zero point of the measurement. The accuracy of the parameterisation of this value has a direct influence on the accuracy of the level measurement by means of the i-Sensor.

Important in Cycle/Clock Control Operation:

- If external level sensors (i-Sensors) are used, they require some lead time after the voltage has been supplied before they display a (correct) measurement value. To avoid incorrect measurements, it is therefore necessary to delay the recording of the measurement value by this lead time. This is done using the **>Measurement Delay<** parameter.
- In addition, the minimum measurement duration for reliable measurement value recording can be defined under **>Measurement Duration<**.

39.2.3 Overlapping

This parameter is only visible/selectable if more than one level sensor has been selected.

By including the individual measurements of a second or a third sensor in the calculations of the transmitter, it is possible to create redundancy between the height measurements (basically as a mutual check) as well as to achieve an averaging of the measured heights.

This overlap is indicated in the graphic by offset colour bars next to the channel (Fig. 39-20).

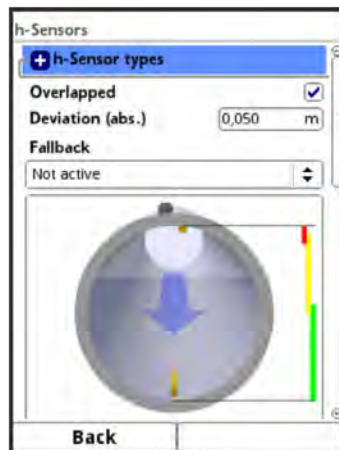

Fig. 39-20 Selection and Display of the Overlap

Use of two or more Level Sensors with Overlap

This variant is selected, for example, if an overflow of the level sensor is to be expected, as in the following example with a pipe measuring section with attached dome.

In **section 1**, a 2-wire pressure probe is installed on the bottom of the pipe measuring section with a measuring span of 0...1 m. The pressure probe is defined as "2-wire Level (2)".

The pressure probe should measure the level in the range between 0 and max. 0.35 m. A second sensor is used for the section above.

In **section 2**, an i-Series sensor (above the water surface) is mounted above the channel. This sensor is to be added from a fill level of 0.32 m and detect the range up to full filling.

Due to this arrangement and parameterisation, the two measurements work overlapping in a range of 0.03 m.

➡ Procedure:

1. Sensor 1 (2-wire pressure probe):
Enter measurement range for level measurement (height min. / max.), set offset to "0.0 m" (4 mA) and measurement span to "1.0 m".
2. Sensor 2 (i-Series sensor):
Enter measurement range (height min. / max.), select sensor type and enter mounting height as well as measurement delay and measurement duration, if necessary.
3. Verify the settings against the graphic above.

39.2.4 Deviation (abs.)

The >Deviation (abs.)< is only visible/selectable if at least two level sensors are connected and the overlap is activated.

The value entered here defines the allowed absolute deviation from the median ¹ of the height measurements to determine if the measurement is valid.

If measurement values of one or more sensors are outside the validity range, the individual measurements are invalid and are not included by the transmitter. In addition, an error message is generated and stored in the error memory.

The measurements continue nevertheless and are checked for validity by the transmitter. As soon as there are measurements within this range again, they are also included in the calculations again and the error message is no longer active.

***1) Determining the Median:**

The measurement values of the sensors within the overlapping measurement ranges are compared by using the median:

- with two sensors, the median is the mean value of the two measurement values (= measurement value mean), i.e.
 - Example:
Sensor 1: 0.9 m
Sensor 2: 1.0 m
 - results in a median of 0.95 m
- with three sensors, the measured value of the middle sensor (= middle measured value), i.e.
 - Example I:
Sensor 1: 0.9 m
Sensor 2: 1.0 m
Sensor 3: 0.92 m
 - results in a median of 0.92 m (measurement value of the middle sensor)
 - Example II:
Sensor 1: 0.9 m
Sensor 2: 1.0 m
Sensor 3: 1.0 m
 - results in a median of 1.0 m (measurement value of the middle sensor)

39.2.5 Fallback

The fallback sensor is always used when no level sensor is operating within its parameterised detection range and within the defined median deviation. This is done independently of the detection range parameterised for the fallback sensor.

39.3 Setting Parameters in Menu v-Sensors

The third important point, in addition to the measurement point and the level sensors, is the parameterisation of the flow velocity sensors. In addition to type and number of sensors, this menu also includes the spatial position. Information in this menu item refers to the defined channel in terms of shape as well as spatial dimension. (see Chapter "39.1.3 Channel Profiles").

39.3.1 Number of Flow Velocity Sensors

A NivuFlow 750/700 transmitter provides the possibility to connect one or more flow velocity sensors.

The number of sensors that can be connected depends on the type of transmitter:

- Type S1/G1 - one flow velocity sensor
- Type SR/GR - one flow velocity sensor
- Type M3/G3 - up to three flow velocity sensors
- Type M9/G9 - up to nine flow velocity sensors



Fig. 39-21 Selection Menu Flow Velocity Sensors

➡ Procedure to select the further sensors:

1. Open the menu >v-Sensors<.

A selection field with the numbers 1...x is shown at the top right of the display. This selection field shows which connected flow velocity sensor is/can currently be displayed and parameterised.

Default Setting: v-Sensor 1 activated as first sensor.
2. Press the right function key (Tab) to switch to v-sensor 2.
3. Check the >Active< box to set the parameters of the activated sensor. The activated sensor is directly visible in the application graphic. The sensor that is currently being parameterised is marked in colour in the graphic. The remaining sensors present are shown in their outlines at the same time.

39.3.2 Sensor Types

You can select a total of five different sensor types:

- Wedge (POA and CS2 sensors)
- Pipe (POA and CS2 sensors)
- Float
- EBM without pressure (connection of a CSM-V100 wedge sensor via the EBM Electronic Box)
- EBM with pressure (connection of a CSM-V1D0 wedge sensor via the EBM Electronic Box)

The selected design >Wedge<, >Pipe< or >Float< is visible in the graphic.

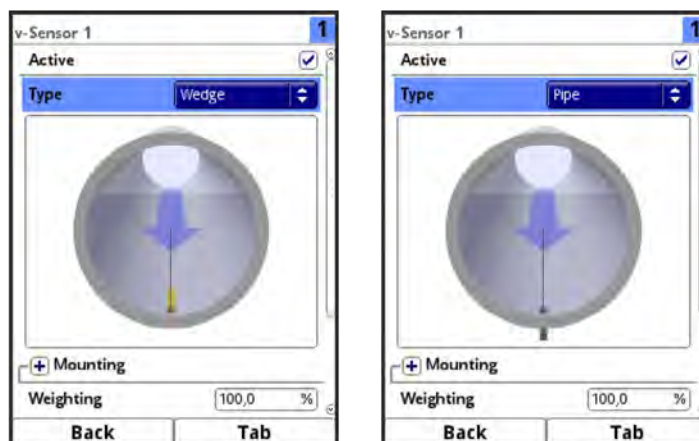

Fig. 39-22 Representation Wedge or Pipe Sensor

39.3.3 Mounting Position of Sensors

For mounting the v-sensors, additional parameters can be entered for the application. These specifications are intended for installation positions that deviate from the factory setting. This applies in particular to installations on wedges or similar or lateral installations in pipes and U-profiles where there is a risk of sedimentation.

➡ Procedure:

1. Rotate the rotary pushbutton until the field >Mounting< is highlighted blue.
2. Press the rotary pushbutton - the PLUS at the front turns to MINUS. An input menu opens.

Selection Flush with Wall (possible only with following channel profiles)

- Pipe
- Egg Profile
- U-Profile

If >Flush with wall< is not activated, the three parameters >Mounting Height<, >Distance Centre< and >Mounting Angle< can be entered.

Instructions for use:

Setting the individual parameters is particularly useful if sensors are mounted off-centre in the channel but, for reasons of recording the velocity profile, are to measure vertically upwards over as large a curvature width as possible, and not at right angles to the mounting wall (Fig. 39-23). The setting >Flush with wall< would record the maximum speed several times and take this into account too much in the calculation.

This setting is also preferred when using two or three sensors in structured cross-sections with sloping floors and/or dry weather flumes.

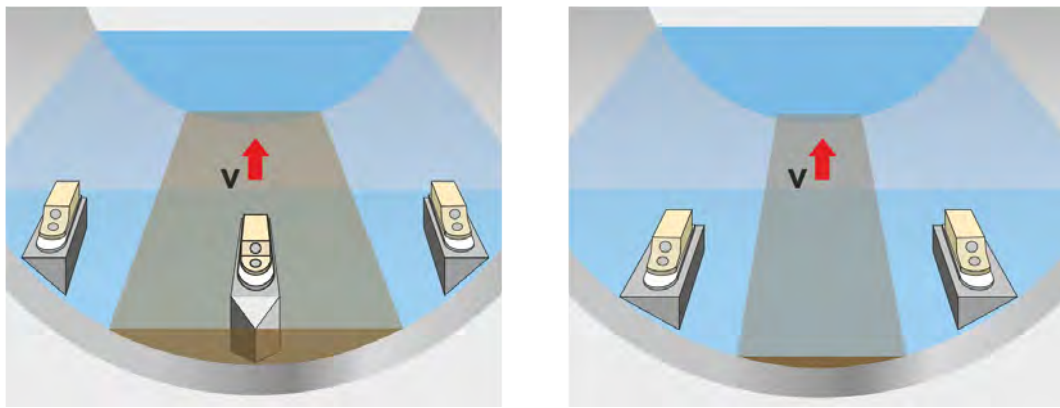

Fig. 39-23 Principle of Sensor Mounting - with Wedge Supports, not flush with Wall

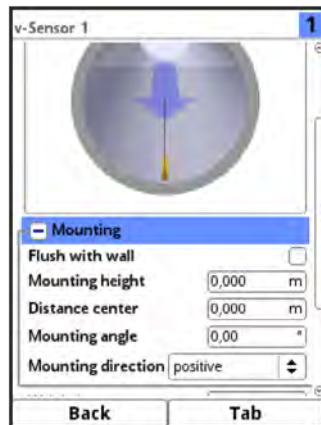

Fig. 39-24 Setting Parameters using Height, Distance and Angle

Alternatively, if the sensors are installed flush with the wall, only enter the beam angle. The entry is made when:

- Wedge sensors are mounted directly on the wall of the inclined/curved surface
- or
- Pipe sensors are inserted at right angles to the pipe wall from the outside.

The use of the **1-parameter parameterisation** only **using the mounting angle** requires that the beam angle to the centre of the circular profile/circular section is known and requires the installation mentioned before to be finished. It significantly facilitates the correct setting of parameters.

➡ Procedure:

1. Check the >Flush with wall< selection box.
The following input fields will be reduced. Only the input field >Mounting Angle< is active.
2. Specify the sensor mounting angle.
3. Check input in relation to the position of the sensor in reality. Pay particular attention to the sensor height in relation to the 0-point of the application.
In the graphic, the sensor is displayed in the entered beam angle.

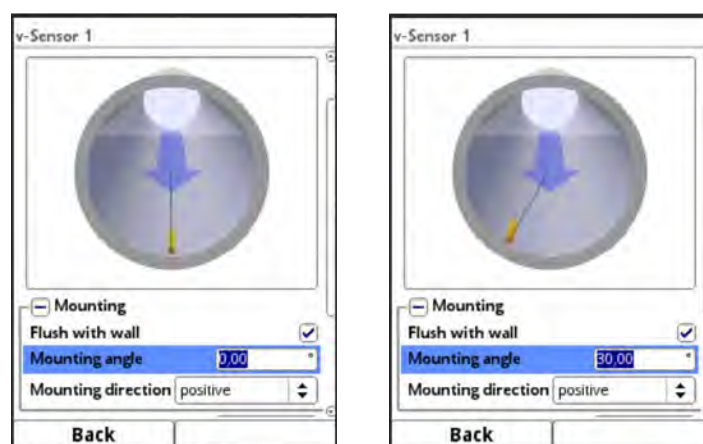

Fig. 39-25 Setting Parameters by Angle Input

Input Field >Mounting Height< (only if >Flush with wall< is not activated/available)

➡ Procedure:

1. Measure the distance from the lower edge of the mounting plate (v-sensor) to the lowest point of the channel bottom.
2. Rotate the rotary pushbutton until the field >Mounting Height< is active.
3. Enter the measured distance.

Default setting: units in METER.

Do not enter a value if the sensor is screwed directly to the floor at the lowest point (or inserted as a pipe sensor from the outside at the lowest point of the application).

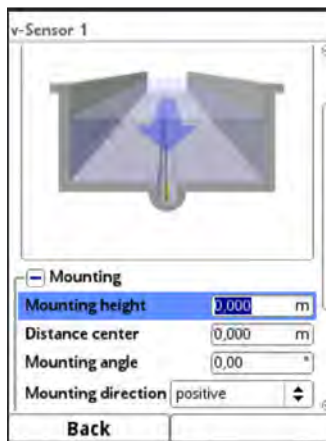

Fig. 39-26 Setting the Mounting height Parameters

In structured channel profiles, e.g. channels with **dry weather flume** and **berm**, the lowest point in the channel corresponds to the zero point. The lowest point in this case is the bottom of the dry weather flume.

If additional sensors are placed directly on the berm, the berm is parameterised as an elevated installation position.

➡ Procedure:

1. For v-sensor 2, enter the elevation of the berm as the mounting height.
2. Check the input of the mounting height in the application graphic.
With the help of the application graphic, you can immediately see whether the mounting height of the v-sensors has been entered correctly. In Fig. 39-27 you can see that the berm was not taken into account in the installation height. The v-sensor is located below the channel bottom in the graphic.

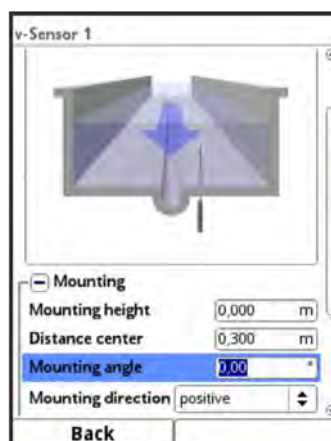

Fig. 39-27 v-Sensor Mounting Height too low

If a sensor has to be mounted on a **block** due to of the risk of **sludge deposits** or **sedimentation**, also take this distance into account.

➡ Procedure:

1. Determine the position of the sensors in relation to the zero point of the application. The reference point is the lower edge of the mounting plate, for tube sensors the horizontal area of the sensor head.
2. Enter this distance in the field >Mounting Height<.

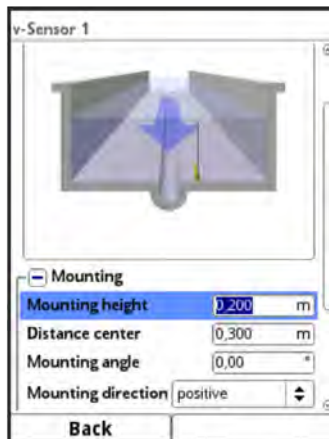

Fig. 39-28 Correctly parameterised Mounting Height v-Sensor

Input Field >Immersion Depth< (only if >Float< is selected)

For float sensors, the depth to which the sensor is immersed below the water surface is entered here. The transmitter includes this depth in the internal calculations.

Input Field >Distance Centre< (only if >Flush with wall< is not activated/available)

The sensor parameters are set as follows:

- v-sensor 1 is always in the centre

The calculation in the transmitter is always based on the central installation of the v-sensor. If the v-sensor is mounted off-centre, this offset must be entered in the >Distance Centre< field.

- Entering a negative value moves the sensor to the left.
- Entering a positive value moves the sensor to the right.

With two v-sensors, the position of the sensors must be entered in the field >Distance Centre<. The value refers to the centre of the application.

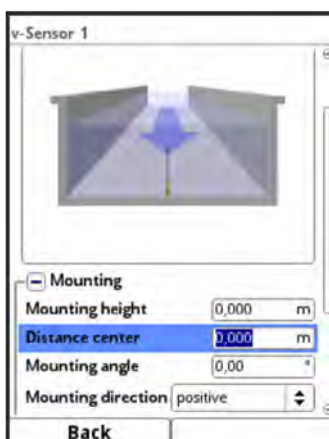

Fig. 39-29 Entering the Sensor Position, relative to the Application Centre

Input Field >Mounting Angle<

Default setting: v-sensor always measures the flow velocity vertically upwards.

In some applications it is necessary to install the sensor at an angle or even horizontally:

- inclined at the slope of a trapezoidal channel
- on the side of channel walls
- in the rounding of a pipe, egg or U-profile

In this case, store the changed beam angle in the transmitter. The reference point is the vertical, upward beam of the ultrasonic signal.

The following applies to the parameterisation of the **inclination of the beam angle** (against the direction of flow):

- negative value - slope to the left
- positive value - slope to the right
- 90° - horizontal beam
- 180° - beam downward (e.g. in applications with float)

Mounting Direction

This special parameter is only used for special applications where the sensor points in the direction of flow.

Default setting: mounting direction of the sensors always >positive< (i.e. measuring direction against the flow direction).



Note

Do not modify this parameter.

If a v-sensor is mounted in the direction of flow, the flow velocity values determined may be less accurate or even invalid.

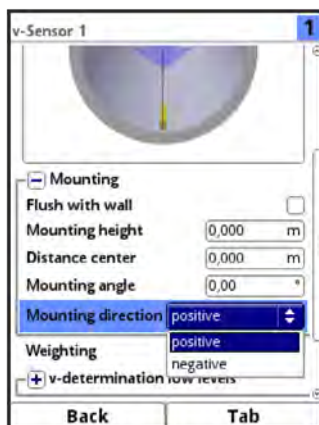

Fig. 39-30 Option to change the Sensor Mounting Direction

39.3.4 Weighting

When using several flow velocity sensors, define the value of each flow velocity sensor to the measurement result of the average total velocity. The entry is made in the >Weighting< field.

Default setting: 100 (%)



Note

The value of the weighting depends on the application and the sensor position.

Applications with multiple flow velocity sensors require extensive knowledge of fluid mechanics and require the use of NIVUS commissioning personnel or an authorised specialist company.

The weighting is a dimensionless number between 0.0 and 100.0.

If only **one** v-sensor is used, entering a value other than "100" does not affect the results because the readings from the single sensor are always counted as 100 %.

When using **two or more** sensors at one measuring point, the entered values for the weighting (= "Wght." in the following examples) of the individual flow velocity sensors influence the total measured values output.

With **two** v-sensors applies:

$$\text{Share Sensor 1} = \frac{\text{Wght. Sensor 1}}{\text{Wght. Sensor 1} + \text{Wght. Sensor 2}} \cdot 100 \%$$

$$\text{Share Sensor 2} = \frac{\text{Wght. Sensor 2}}{\text{Wght. Sensor 1} + \text{Wght. Sensor 2}} \cdot 100 \%$$

With **three** v-sensors applies:

$$\text{Share Sensor 1} = \frac{\text{Wght. Sensor 1}}{\text{Wght. Sensor 1} + \text{Wght. Sensor 2} + \text{Wght. Sensor 3}} \cdot 100 \%$$

$$\text{Share Sensor 2} = \frac{\text{Wght. Sensor 2}}{\text{Wght. Sensor 1} + \text{Wght. Sensor 2} + \text{Wght. Sensor 3}} \cdot 100 \%$$

$$\text{Share Sensor 3} = \frac{\text{Wght. Sensor 3}}{\text{Wght. Sensor 1} + \text{Wght. Sensor 2} + \text{Wght. Sensor 3}} \cdot 100 \%$$

For **four and more** v-sensors, the formula can be extended by the number of sensors as desired.

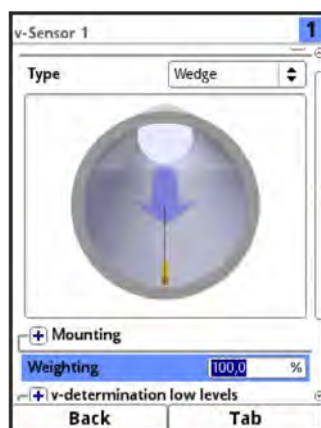

Fig. 39-31 Weighting v-Sensors

39.3.5 v-Determination low Levels

Physically and due to their design, the flow velocity sensors can no longer measure the flow velocity when the filling level falls below a minimum level. This minimum level is approximately between 3 and 8 cm, depending on the sensor type.

This minimum level is called **h-crit**.

Unfavourable applications (e.g. strong wave movements) or the elevated installation of the sensors may increase this value.



Fig. 39-32 Submenu: v-Determination low Levels

The >v-Determination low Levels< menu facilitates the recording of temporarily low flow rates (e.g. nightly discharges, extraneous water or similar).

Requirements for this function:

- No backwater in the application
- Reliable and exact measurement of the existing filling level, even down to a level of 0 mm.

Tip:

This measurement can only be done with an air-ultrasonic measurement (e.g. i-Sensor).

Working principle of the function:

If the level falls considerably, flow velocity can no longer be measured after a certain point.

Within a range of 3...6 cm above the minimum level (h-crit), at which a flow velocity can still be measured, the transmitter creates an internal v/h value table.

The parameterised channel shape is taken into account when calculating the v/h value table.

If no more flow velocity can be detected, but a filling level is measured, the system automatically calculates a "suitable" flow velocity within this value table.

v-Determination Automatic

- Rotate the rotary pushbutton until the field >v-Determination Automatic< is highlighted blue.

Default setting: function activated (box checked).

- When h-crit (critical level) is reached, the last measured flow velocity value is automatically stored as the calculation value at lower levels.
The last measured flow velocity value is in the range of approx. 3...6 cm above h-crit and depends on the detected sensor type. This value is entered automatically by the measurement system.
If the level drops below h-crit, the flow velocity value automatically entered by the system is used for the flow calculation.
As soon as the level exceeds h-crit and the range above it (3...6 cm) again and then

falls below h-crit again, the newly determined velocity value is used for the next flow calculation.

- If the >v-Determination Automatic< function is deactivated and h-crit is undershot, the system calculates the flow with the entered flow velocity value of >v-manual< from the value >h-manual<.
- If very low levels and backwater are to be expected in the channel, deactivate the checkbox >v-Determination Automatic<.
- Deactivating the selection field >v-Determination Automatic< makes also sense if a standstill of a small medium volume is likely at zero flow.
Set the value in the >v-manual< field to "0". The system then does not calculate a flow rate at the lowest levels.

h-crit automatic

The automatic calculation of the critical height includes the information of the sensor type and the parameterised installation height (see Chapters "39.3.3 Mounting Position of Sensors", Fig. 39-26). The possible lowest level at which a flow velocity can still be measured is automatically determined by the transmitter. If the function is deactivated, the system uses the value entered in >h-manual< as h-crit.

Default setting: function activated (box checked).

h-manual / v-manual

The value pair h-manual and v-manual is used to calculate the discharge curve as long as there is no automatic recording yet or it is deactivated.

These input fields are used to manually enter a fill level / flow velocity.

The flow velocity value entered can be calculated or modelled for the corresponding level, e.g. by means of hydraulic calculations or discharge models.

Default setting: >h-manual< is "0".

h-crit

This input field is used for the v/h calculation. To do this, enter the level from which the system is to switch to v/h calculation.

Note:

>h-crit< is only active if >h-crit automatic< is deactivated.

v-crit

Enter the velocity value that is part of the >h-crit< point of the discharge curve to be calculated.

39.3.6 Limiting the Velocity Evaluation

The two input fields >v-Minimum< and >v-Maximum< are relevant for limiting the flow velocity evaluation. The maximum permissible negative and positive velocity values can be entered here.

Possible settings:

>v-Minimum<: -3.500...0.000 m/s

>v-Maximum<: 0.000...6.000 m/s

Absolute measurement span: 7.000 m/s,

i.e. with >v-Minimum< -2.000 m/s, >v-Maximum< can be no more than 5.000 m/s.

A classic application is the prevention of the evaluation of negative flow velocities (backflow). In this case >v-Minimum< is set to "0".



Note

An increase of the possible flow velocity evaluation beyond the technical limits given in chapter "17 Specifications" is not possible and is blocked when trying to input.



Fig. 39-33 Limiting the Velocity Evaluation

39.3.7 Data Transmission Rate

Baud Rate

Setting the data transmission rate between the transmitter and sensor.

Default setting: 115200 Baud.

NIVUS strongly recommends that you keep this setting. Only in very rare cases, when there are communication problems between transmitter and sensor (e.g. when using a very long cable), a reduction of the Baud rate can be helpful. A change should only be made after consultation (or instruction) with the NIVUS head office in Eppingen.



Fig. 39-34 Baud Rate

39.4 Setting Parameters of Inputs and Outputs (analogue and digital)

In this menu, the functions of the analogue and digital inputs and outputs are defined. Further parameter settings such as measurement and output spans, offsets, limit values, error reactions etc. are also possible in this menu.

The >Inputs/Outputs< menu is opened via the main menu.

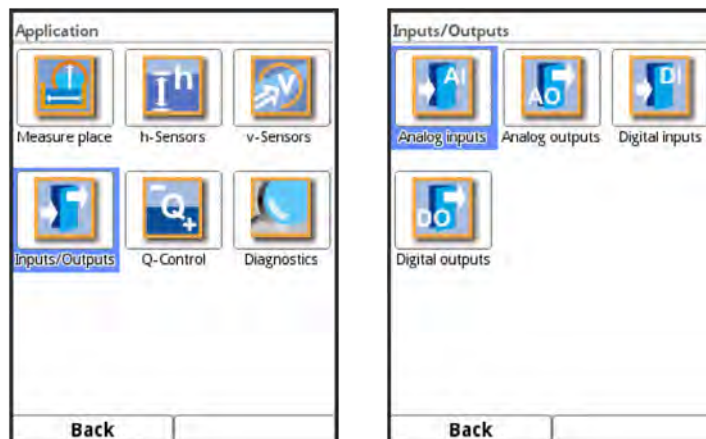

Fig. 39-35 Selecting Inputs and Outputs

The Inputs/Outputs menu is divided into four sections:

- Analogue Inputs
- Analogue Outputs
- Digital Inputs
- Digital Outputs

39.4.1 Analogue Inputs

The number of analogue inputs depends on the device type:

- Type S1/G1 = two analogue inputs
- Type SR/GR = five analogue inputs
- Type M3/G3 = eight analogue inputs
- Type M9/G9 = eight analogue inputs

The available analogue inputs are shown in the top right corner of the display.

Select the analogue inputs one after the other by pressing the right control button >Tab<. The selected input is shown in plain text in the top left corner of the display.

Default setting: analogue inputs inactive.

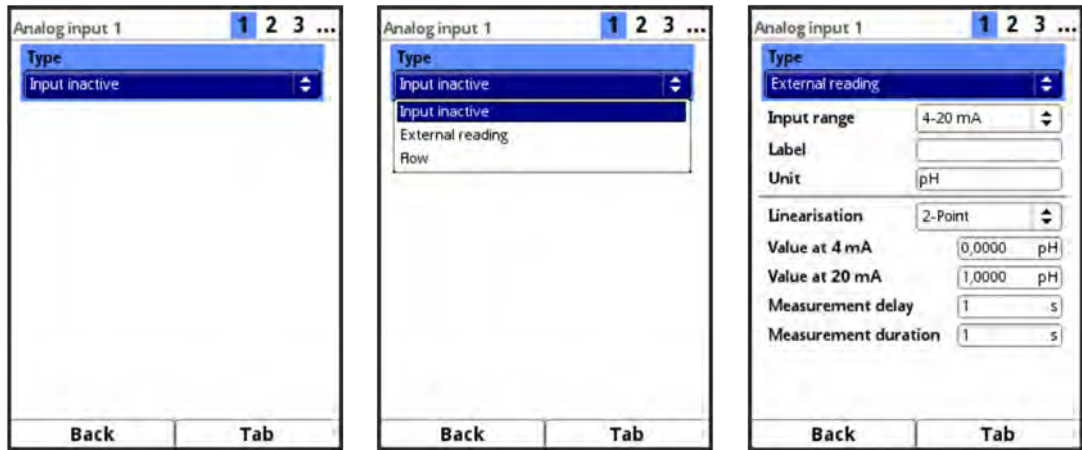

Fig. 39-36 Activation Analogue Inputs / Measurement Delay/Duration

The analogue inputs can be used as external measurement values (e.g. temperature in °C) or for flow measurement (flow calculation by means of a Q/h characteristic, e.g. additional overflow volume calculation at overflow weirs or Venturi measurements by means of a level measurement). The transmitter can hence be used as an additional data logger for measurement values from other systems. Its task as a flow transmitter is not affected by this.

In the case of NivuFlow 750 type M9/G9 transmitters with several measurement places, a further external flow measurement value (e.g. from a separate EMF) can also be applied and thus a total flow value can be calculated from up to four individual measurement values.

Furthermore, it is possible to use analogue input 1 as an external setpoint input when the controller function is activated. In this case, analogue input 1 is hidden during parameterisation. The numbers in the top right corner then start at 2.

The analogue input can also be used for the input of an external sludge level measurement. This ensures that any sediment layer present on the channel bottom is subtracted from the wetted hydraulic area to reduce calculation errors.

In **Cycle/Clock Control Operation** of the transmitter, if external level sensors (i-Sensors) are used, these sensors require some lead time after the voltage has been supplied before they display a (correct) measurement value. To avoid incorrect measurements, it is therefore necessary to delay the recording of the measurement value by this lead time. This is done using the >Measurement Delay< parameter (Fig. 39-36 Fig. 3).

In addition, the minimum measurement duration for reliable measurement value recording can be defined under >Measurement Duration<.

The use of these two parameters is not relevant when not in cycle/clock control mode.

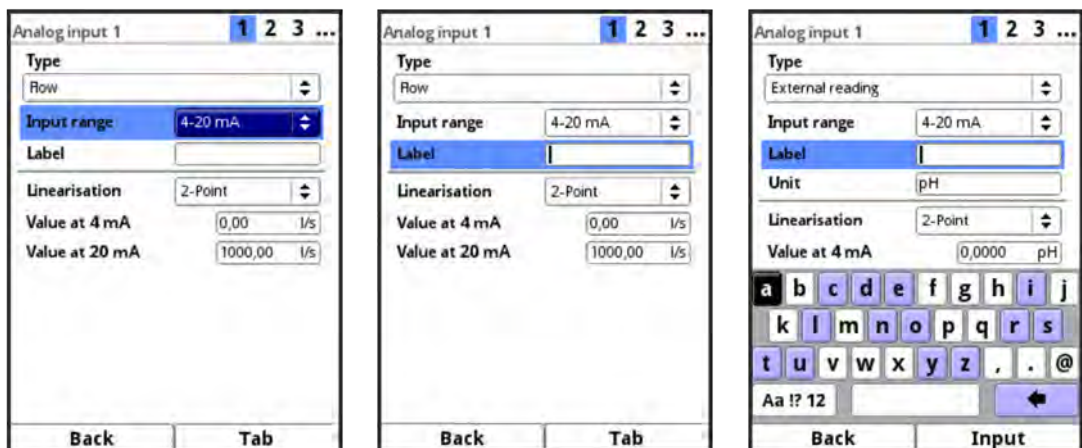

Fig. 39-37 Setting Parameters Analogue Input

After activating the analogue inputs, the input range can optionally be set to >0-20 mA< or >4-20 mA<.

Under Label, a freely selectable name with up to 16 characters can be entered, which is displayed, for example, under Diagnostics for the respective analogue input.

The field for selecting the units is designed as a changeable text field for "External reading", for entering individual units. The number of characters for the units is limited to a maximum of five characters.

For "Flow", the unit (according to the units selected in the country settings) is fixed and cannot be changed.



Note

Input via keypad: see Chapter "28.3 Input via Keypad".

Finally, parameterise the scaling of the storage.

39.4.2 Analogue Outputs

The number of analogue outputs depends on the device type:

- Type S1/G1 = two analogue outputs
- Type SR/GR = two analogue outputs
- Type M3/G3 = four analogue outputs
- Type M9/G9 = four analogue outputs

The available analogue outputs are shown in the top right corner of the display.

Pressing the right control key >Tab< selects the analogue outputs one after the other. The selected analogue output is shown in plain text in the top left corner of the display.

Default setting: analogue outputs inactive.

Different functions can be assigned to the analogue outputs. It is possible to assign the same function to two analogue outputs in different measurement ranges.

- Example:
 - Analogue output 1 = flow 4-20 mA corresponds to 0-100 l/s
 - Analogue output 2 = flow 4-20 mA corresponds to 0-5000 l/s

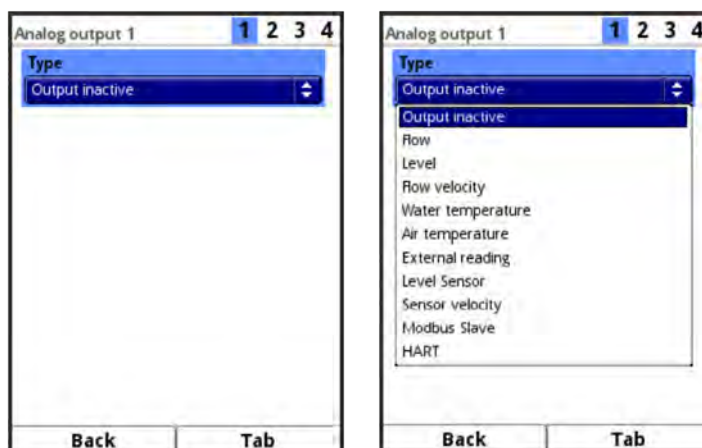

Fig. 39-38 Activation Analogue Outputs

The following functions of the analogue output are possible:

- **Flow**
The flow rate of the application (calculated from average flow velocity and wetted cross-section) is output at the selected analogue output.
- **Level**
The current filling level of the measurement place is available at the selected analogue output. This is the level that is active in the >Application< / >h-Sensors< menu for the current height range.
- **Flow Velocity**
The average calculated flow velocity (also calculated from two, three or more sensors) used to calculate the current flow rate is available at the selected analogue output.
- **Water Temperature**
The medium temperature detected by the flow velocity sensor can be output at the selected analogue output.
- **Air Temperature**
If an air-ultrasonic sensor type OCL or an intelligent i-Series sensor is used in the application, this can be used to output the measured air temperature, which is measured by the sensor to compensate for the sound transit time error.
- **Sludge Level**
In applications where the rate is measured from above by means of a float and the level is recorded with an external or OCL sensor and simultaneously with a water-ultrasonic sensor, the sludge level can be determined and output from the difference between the two level sensors, taking into account the immersion depth.
Tip:
This selection is only visible if "Float" is selected in the v-sensor menu and "Water-US Sludge Level" is selected in the h-sensor menu.
- **External Reading**
Measurement values applied to the analogue input and linearised, if applicable, can be output here again.
- **Level Sensor**
The individual fill levels of the connected sensors measured from the bottom can be output here.
When using a combi wedge sensor, this is either the reading of the integrated pressure measurement cell or the water-ultrasound measurement value (depending on the type of combi sensor used).
For combi sensors that contain both measurements, a selection option for one of the two methods is displayed.
- **Sensor Velocity**
If several flow velocity sensors are used (only possible with Types M3/G3/M9/G9) measuring path velocity of a single desired flow velocity sensor can be selected here and output in analogue form.

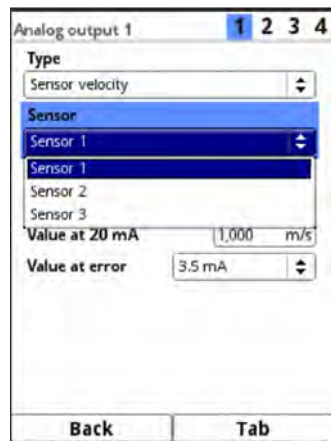

Fig. 39-39 Selection Sensor Velocity

- **Modbus Slave**
The value of the analogue output can be set by other systems via Modbus.
See also Chap. "1.1 Applicable Documentation": Technical Description NIVUS MOD-BUS.
- **HART**
Activation of any existing HART slave functionality for the digital transmission of further measurement values.
The values "Level" and the respective measured and calculated average "Velocity", "Medium Temperature" and "Flow Rate" are transmitted.
This function **requires** the "HART Protocol of the Analogue Output" extension (see Chap. "18.1 Device Versions", "Tab. 4 Product Structure": "Extension" = 1).

The following settings of **Output Range**, **Output Span** and **Value at Error** apply to all functions explained above.

- After selecting the function, the output range can be selected:
 - 0-20 mA
 - 4-20 mA
- Then set the output span.
- If the measurement value fails, an error behaviour can be set for the analogue output. The following settings are possible in the event of an error:
 - 0 mA
 - Hold value (hold the last reading that is still valid) (Hold))
 - 3.5 mA
 - 21 mA

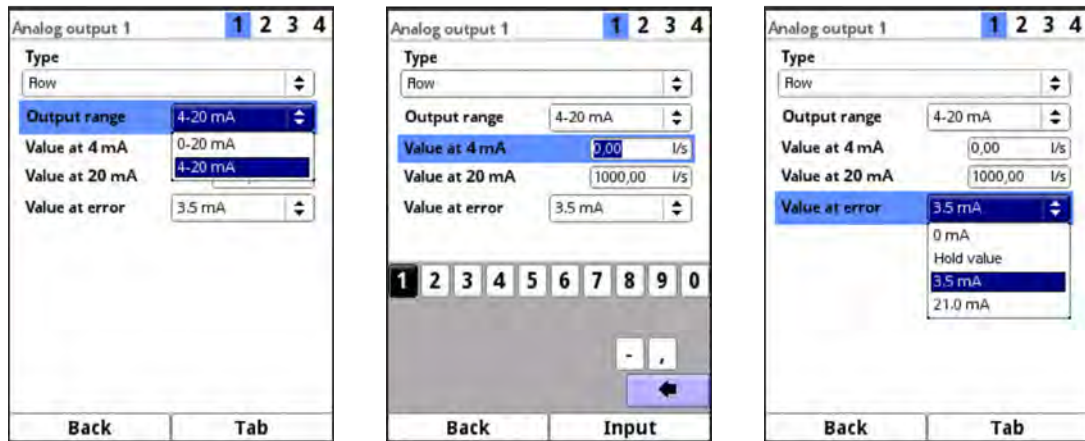

Fig. 39-40 Output Range / Output Span / Value at Error

39.4.3 Digital Inputs

The number of digital inputs depends on the device type:

- Type S1/G1 = two digital inputs
- Type SR/GR = seven digital inputs
- Type M3/G3 = ten digital inputs
- Type M9/G9 = ten digital inputs

The available digital inputs are shown in the top right corner of the display.

Pressing the right control key >Tab< selects the digital inputs one after the other. The selected input is shown in plain text in the top left corner of the display.

Default setting: digital inputs inactive.

Under Label, a freely selectable name with up to 16 characters can be entered, which is displayed, for example, under Diagnostics for the respective digital input.

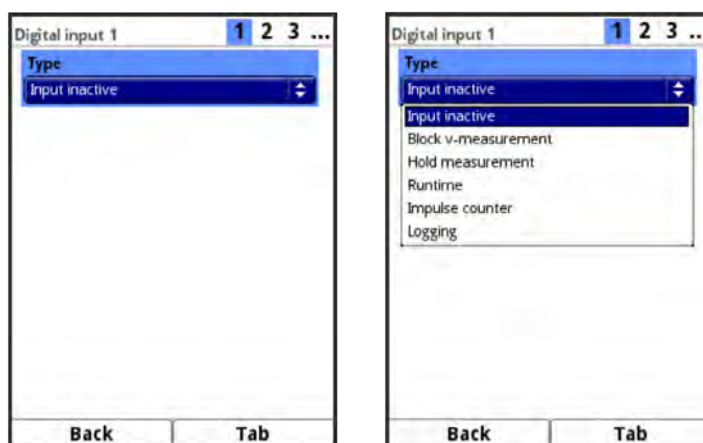

Fig. 39-41 Activation Digital Inputs

The following functions can be assigned to the digital inputs:

- **Block v-Measurement**
By means of an external contact (float switch, pressure bell switch, etc.) the flow measurement can be blocked as long as a signal is present at the digital input. Applications for this are, for example, heavily dammed overflow channels without actual overflow, which show movement due to wind, waves, ship traffic or pump applications where the pipe runs empty.

Here the measurement is enabled via the contactor in the separating structure. The contactor must be positioned just before the start of the overflow.

In addition, the logic can be changed as follows:

- non-inverted digital input
- inverted digital input

- **Hold Measurement**

Activation of this digital input causes a "freezing" of the flow measurement value at the time of activation itself. Changing readings or values going to "0" no longer have any effect on the measurement value while the signal is applied to the input. The flow measurement value has an influence on a possible downstream process.

Application Example:

Maintenance/cleaning of the measuring section is carried out, which must be shut down for a short time for this purpose. However, the subsequent process (e.g. regulation with reference to the measured rate) should still continue.

In addition, the logic can be changed as follows:

- non-inverted digital input
- inverted digital input

- **Runtime**

The duration of the signal present at the digital input is recorded and stored by the system. This recording is used, for example, for pump or device running times.

In addition, the logic can be changed as follows:

- non-inverted digital input
- inverted digital input

- **Impulse Counter**

The number of the signals present at the digital input is counted and stored by the system. The evaluation of the counting impulse is done by detecting the change of state of the digital input (1->0 or 0->1).

A minimum impulse duration of 100 ms is required for reliable detection.

In addition, the logic can be changed as follows:

- rising Edge (change of state from "0" to "1")
- falling Edge (change of state from "1" to "0")

- **Logging**

An applied signal is recorded and stored with start and end time (time stamp function).

The possible applications are:

- Access control
- Logging of events
- Runtimes etc.

In addition, the logic can be changed as follows:

- non-inverted digital input
- inverted digital input



Fig. 39-42 Changeover options Edge and Logic

In addition, after activating the quantity controller in the flow controller menu (Q-controller menu), the following additional functions can be used from digital input 4 or digital input 7 (for Types M3/G3/M9/G9):

- DI 4 / DI 7: >Slider Way CLOSED<
- DI 5 / DI 8: >Slider Way OPEN<
- DI 6 / DI 9: >Slider Torque CLOSED<
- DI 7 / DI 10: >Slider Manual<

These parameters are permanently assigned to the digital inputs.

39.4.4 Digital Outputs

The number of digital outputs depends on the device type:

- Type S1/G1 = two digital outputs
- Type SR/GR = five digital outputs
- Type M3/G3 = six digital outputs
- Type M9/G9 = six digital outputs

The available digital outputs are shown in the top right corner of the display.

Pressing the right control key >Tab< selects the digital outputs one after the other. The selected output is shown in plain text in the top left corner of the display.

Default setting: digital outputs inactive.

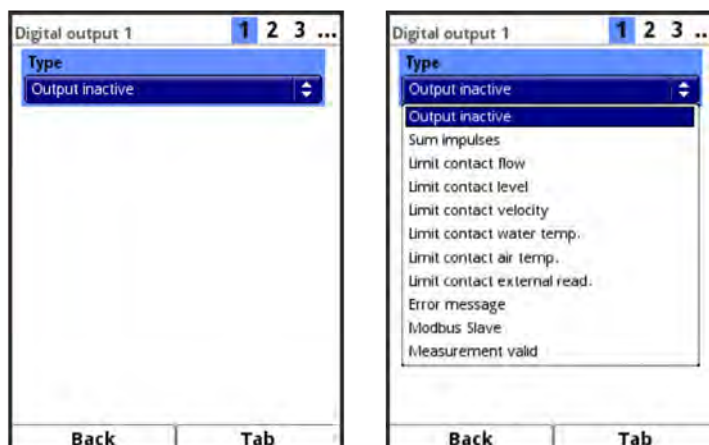

Fig. 39-43 Activation Digital Outputs

The following functions can be assigned to the digital outputs:

- **Sum Impulses**

Quantity-proportional sum impulses of the main sum counter ("Sum" in the main display) are output.

Parameter setting options:

- Logic (normally closed/normally open)
- Negative sum impulses
- Quantity (pulse per quantity to be defined)
- Duration (relay energised/de-energised);
Adjustable duration: 100...5,000 ms;
The pulse/pause ratio is always 1:1.

If the output frequency of the impulse output is below the frequency of the flow rate when the flow rate increases sharply, the total impulses that have not yet been output are stored internally until the calculated flow rate falls below the impulse frequency again. After that, the sum impulses are processed.

In addition, it is possible to enable the output of negative sum impulses. If this box is activated, only the negative sums (backflow) are output. The positive sums are ignored.

Prerequisite for this selection:

Measuring negative velocities (v-Minimum) is permitted (see Chap. "39.3.6 Limiting the Velocity Evaluation").



Fig. 39-44 Setting Parameters Impulse Generator

- **Limit Contact Flow**

Set a flow limit value for >Threshold On< and >Threshold Off< respectively. If this flow limit is exceeded, a digital signal is output. If the flow falls below the second flow limit value, this digital signal is reset = hysteresis function to prevent fluttering outputs.

In addition, the logic can be changed: normally closed / normally open

By ticking >Absolute<, the setting applies to the positive and the negative range.

Furthermore, the behaviour in the event of an error, a delay time and a hold time can be set. Details can be found in the application example below.

Application example for Limit Contact Flow:

- Set >Threshold On< to 1000 l/s.
- Set >Threshold Off< to 900 l/s.
- Activate >Absolute< by checking the box.

If the flow now exceeds the value of 1000 l/s, the digital output is activated.
When the flow falls below 900 l/s, the digital output is deactivated again.
If the flow continues to drop to 0 l/s **and** the flow direction reverses, then the transmitter will measure a **negative flow** when the negative flow rate measurement is activated.
If the negative flow now rises to -1000 l/s, the digital output is activated again.
When the negative flow rate falls below -900 l/s, the digital output is deactivated again.

Info:

If a **measurement value error** occurs (measured value is recognised as invalid by the system), the reaction of the digital output can be defined. A distinction can be made between "Off" (relay energised), "On" (relay de-energised) and "Hold value" (relay remains in the position where it was before the error).

By entering a **delay time**, the relay only switches when the conditions for the state to be output are present without interruption for at least this entered delay time and also continue to be present at the time switching point. This function is often used to ignore short-term limit value violations (caused by sloshing water, waves, brief pumping processes or similar).

Entering a **hold time** has the exact opposite effect as the delay time. Here, a reaction of the digital output can be prevented by entering the time when a limit value is briefly undershot.

At the same time, this parameter also offers the possibility to set a required minimum output time even with only very short pending limit values.



Fig. 39-45 Setting Parameters Limit Contact

- **Limit Contact Level**

The limit contact level is used in exactly the same way as the limit contact flow.

Setting the level limit value.

The level that is active in the menu >Application< / >h-Sensors< for the current height range is used for the calculation. A freely selectable level sensor cannot be used.

The settings and functionalities correspond to the procedure for >Limit Contact Flow< (see Page 129).

- **Limit Contact Velocity**

Here the digital signal is output when an adjustable velocity limit value is exceeded.

The average calculated flow velocity (also calculated from two, three or more sensors) is used for this function.

The settings and functionalities correspond to the procedure for >Limit Contact Flow< (see Page 129).

- **Limit Contact Water Temperature**

The digital signal is output here when the water temperature exceeds or falls below an adjustable value.

The settings and functionalities correspond to the procedure for >Limit Contact Flow< (see Page 129).

Application examples for limit contact water temperature:

- *Exceeding the permissible temperature in Ex areas*
- *Exceeding the permissible operating temperature of the sensor (danger of sensor damage)*
- *Frost protection alarm (danger of freezing of the measurement technology)*

- **Limit Contact Air Temperature**

The limit contact air temperature only works when using an OCL air ultrasonic sensor or an i-Sensor with HART protocol that is connected via a HART input on the NF750 or iXT/MPX.

The settings and functionalities correspond to the procedure for >Limit Contact Flow< (see Page 129).

- **Limit Contact Sludge**

For part filled applications, the sediment level can be determined and output. The requirements for this are:

- Use of a float
- Determination of the sediment distance by means of water-ultrasound from the float
- Determination of the water level using an external sensor or air-ultrasonic sensor type OCL

The sediment level can be calculated from the difference between the two level sensors. If the sludge level is exceeded or not reached, a limit contact can be set or reset. The immersion depth of the water-ultrasonic sensor, measured from the water surface, must be taken into account when setting the parameters (entering the position of the sensor attached to the float).

Attention:

Soft sludge layers may not reflect ultrasound. In this case, the sediment height cannot be measured.

The settings and functionalities correspond to the procedure for >Limit Contact Flow< (see Page 129).

- **Limit Contact External Reading**

The limit contact for an external measurement can only be used if at least one analogue input is set to "External Reading".

The settings and functionalities correspond to the procedure for >Limit Contact Flow< (see Page 129).



Fig. 39-46 Setting Parameters Limit Contact External Reading

- **Error Message**

By activating the individual selection fields using the push button, the individual error types to be output can be assigned to the digital output.

The possibility of output >h-Measurement< only exists when using 4-20 mA level inputs (falling below 3.6 mA) or when using a water ultrasonic sensor type POA-VxH, POA-VxU and/or air ultrasonic sensor type OCL.

The error >T-Measurement< is possible when using POA, CS2, CSM and OCL sensors. It signals the complete failure of the temperature measurement in these sensors. For exceeding or falling below temperature limits, use the limit contact function.

The error >Q-Controller< is only visible when the controller function of the transmitter is activated. It outputs errors in the control behaviour, missing external setpoints, a blocked slider blade, etc. Detailed information see Chap. "39.5 Setting Parameters of the Flow Controller (Q-Controller)". The output of the system errors occurs, among other things, during manual booting and updating of the unit, during restart after a programme sequence error, during cold starts (start-up after power failure) and after setting the time.

The errors can - like the other functions - be output with a delay or continue to be output (hold) for a definable time after the cause of the error has been eliminated.



Digital output 2 of type S1/G1/SR/GR cannot be selected as error output

Digital output 2 of the types mentioned before is not suitable as an error output since it is designed as a bistable relay. The relay remains in its last position in a de-energised state and cannot be used for error messages.



Fig. 39-47 Error Message

- **Modbus Slave**

The digital output can be used via the Modbus for the controlled output of a signal from other systems. The logic can be chosen via "Normally closed" or "Normally open".



Fig. 39-48 Modbus Slave

- **Slider OPEN / Slider CLOSED**

For transmitters type SR/GR with activated controller function, digital output 4 is reserved for the control of >Slider CLOSED< and digital output 5 for the control of >Slider OPEN<.

For transmitters type M3/G3/M9/G9 these are digital output 5 for >Slider CLOSED< and digital output 6 for >Slider OPEN<.

The slider controls cannot be made with any other digital output. The visibility and selection of the slider control is therefore limited to these two digital outputs respectively.



Fig. 39-49 Slider OPEN / Slider CLOSED

- Measurement valid (only in conjunction with Cycle/Clock Control Mode)**
The transmitter signals via this output that the measured values are valid for this measurement cycle.
This time period is particularly important when using externally connected data loggers so that they can access data values in cycle/clock control mode (see chapter "41.5.2 Cycle Mode / Clock Control"). Enter the value for "Hold" manually.
- Active (only in conjunction with Cycle/Clock Control Mode)**
As soon as the transmitter is active, this information is communicated to an externally connected data logger, which is then activated. The logic can be chosen via "Normally closed" or "Normally open".

39.5 Setting Parameters of the Flow Controller (Q-Controller)

For transmitters with available controller function, this must first be activated in the menu >Application< / >Q-Controller< by setting the check mark.

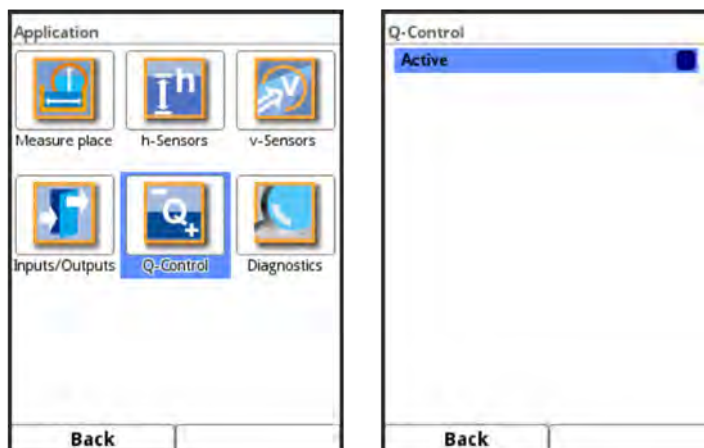

Fig. 39-50 Flow Controller (Q-Controller)

The following parameters are then available for setting the flow controller (Q-Controller).

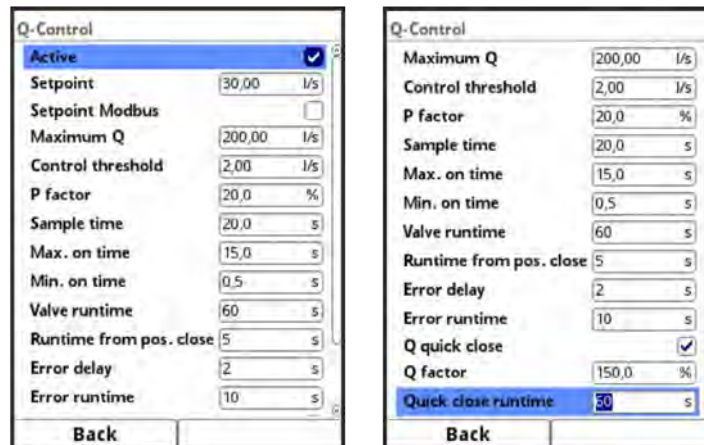

Fig. 39-51 Setting parameters for the flow controller (Q-Controller)

- Setpoint**
 This parameter defines the flow value to be controlled in the application. This is the internal setpoint of the unit. If an external setpoint is also used, parameterised via the associated analogue input, the internal setpoint becomes ineffective. Only in the event of an error (e.g. cable break of the external 4-20 mA setpoint) does the firmware use the additionally entered internal setpoint as a substitute.
- Setpoint Modbus**
 This activation field is only visible if no external setpoint is used via the analogue input.
 In this case, the control setpoint is specified by the Modbus. If the Modbus does not provide a preset, the parameterised internal control setpoint is accessed.
- Maximum Q**
 This parameter identifies the maximum occurring flow value at the measurement place. It is used to calculate the actuating time.
- Control Threshold**
 The control threshold is also called control deviation in the control circuit area. This parameter defines the permissible control deviation of the control circuit without a control signal being output for the slider.
 Flow measurements - especially in the partial fillings - tend to fluctuate slightly in practice for hydraulic reasons. If no setpoint deviation were allowed, the controller would constantly try to match the actual value exactly to the setpoint. This leads to constant actuator actuation and ultimately to increased wear and even defect of the slider.
Info:
In the area of sewer network management (stormwater treatment plants such as stormwater overflow tanks, stormwater retention basins, etc.), the DWA prescribes separation severities of 20 % for throttle discharge. For low-wear operation of the controller, this means a reasonable setting of the permissible control deviation of approx. 10...15 % of the setpoint.
- P-Factor**
 The P-Factor (proportionality factor) indicates which actuating time effect a deviation Δw from the setpoint has.
 The greater the proportionality factor, the longer the actuating time of the slider with the same control deviation.
- Sample Time**
 The sample time, also called cycle time, describes the processing interval of the controller. A short cycle time accelerates the control behaviour (faster reaching of the setpoint in case of a control deviation), but leads to oscillation of the control circuit after a certain point in case of longer running times of the medium (= idle time in the

control circuit) between the actuator and the measuring point.

A long cycle time reduces the tendency of the controller to oscillate, but at the same time increases the inertia of the control system.

Practice-oriented value:

$$\text{Sample time} = \frac{\text{average flow velocity}}{\text{Distance between actuator and measurement [m]}} \cdot 1.3$$

- **Max. On Time**

The maximum control time for the actuator avoids overshooting of the controller function in the case of extremely large setpoint deviations and actuators with a short total slider runtime.

- **Min. On Time**

The minimum control time (control impulse time) refers to the minimum running time of the actuator.

If the actuating times are too short, they are added up until the minimum actuating time is exceeded so that the control impulses have such a long time that this actuation still causes a change in the actuator due to mechanical play.

Practice-oriented value:

$$\text{Min. On Time} > \text{Relay switching time/switching contactor} + \text{Motor start-up time} + \text{Gear backlash} + \text{Slider play}$$

- **Valve Runtime**

The parameter is used to monitor spindle breakage, slider blade breakage, power failure of the servomotor, gear damage and other errors that manifest themselves in the fact that no further positioning movements are carried out despite control signals being present. The slide valve runtime is also used to calculate the actuating time. If the actuator does not reach the CLOSED limit switch after the specified total slider runtime, the system goes into error mode.

Practice-oriented value:

$$\text{Slider runtime to be set} = \frac{\text{Time of the slider from OPEN to CLOSED position in continuous operation}}{\cdot 1.2...2.0 \text{ *)}}$$

*) smaller factor with longer slider runtime



The slider runtime has an influence on the calculation of the impulse time and must not be set to "0".

- **Runtime from Pos. close**

Defined time period until the zero position/error position is approached after a closing (CLOSED position).

- **Error Delay**

This parameter hides error messages that occur for a short time so that the system does not immediately go into error mode in the event of slightest disturbances. Specify the time in seconds.

- **Error Runtime**

Movement time of the slider in the "OPEN" direction in the event of an error.

A error occurs when the slider does not close due to stones or similar and the torque switch "CLOSED" is triggered before the switch "Way CLOSED".

Specify the time in seconds.

- **Q Quick Close**

This parameter activates the quick close function in the case of an event and enables the following two parameters: Q-Factor and Quick Close Time.

The quick close function is mainly used for large nominal diameters, long slider runtimes and long idle times. In the event of sudden rainfall events with torrential water volumes in large channels, it is used to move the control valve from the "OPEN" state to a time-defined, partially closed "CLOSED" state, irrespective of the calculated actuating time, thus preventing flooding. The closing takes place in continuous operation without interrupting the slider runtime.

- **Q-Factor**

Only visible with activated Q Quick Close.

If the control setpoint is abruptly exceeded by the set Q-Factor, the slider moves to the "CLOSED" state (in the time defined under Quick Close Time).

The setting is made in % and refers to the setpoint.

- **Quick Close Runtime**

Only visible with activated Q Quick Close.

When the quick close is triggered, the slider closes from the "OPEN" state in the defined time.

39.6 Diagnostics

The diagnostics menu is required at the end of parameterisation or for troubleshooting during operation. Therefore, this menu is described after setting the parameters in Chapter "Diagnostics" starting at Page 187.

40 Parameter Menu Application/Combi

40.1 General Information

The NF750 M9/G9 transmitters are characterised by the fact that more than three flow velocity sensors can be connected to them by using an MPX or iXT. Depending on its configuration (see also Chapter "18.1 Device Versions"), the transmitter can evaluate one, two or three different measurement places.

The transmitters with two/three measurement places also have an internal, "virtual" measurement place, the combination measurement place. This allows to combine the flow totals of the real measurement places into a common, "virtual" third or fourth measurement place. Additions or subtractions of the individual totals are possible, e.g. in order to

- determine the discharge total from the measurement of two inlets by adding them together
- or in an application with three inlets and one outlet, determine the inflow total 3 by subtracting the measured inflow total 1 and 2 from the measured discharge total.

Furthermore, it is possible to connect an external 4-20 mA flow measurement value (e.g. the output of an inductive flow meter) to an analogue input of the NivuFlow 750, define this analogue input as flow measurement value 4 and include it in the calculation of the combination measurement place.



Delivery status of the transmitters with multiple measurement places

On delivery, only measurement place MP1 is activated for the transmitters with multiple measurement places. Therefore, all available sensor inputs and all analogue and digital inputs/outputs are also assigned to the MP1 measurement place.

Prior to setting the parameters of the combi measurement place, the measurement places 2/3 must be activated. (see Chap. "39.1.1 Active/Activation of Measurement Places (only for NivuFlow 750 Type M9/G9 with multiple measurement places)").

The corresponding assignment of the sensors and inputs/outputs to the measurement places is carried out according to Chap. "45.3 For Transmitters Type M9/G9".

40.2 Measurement Place Name

The proposed **name of the measurement place** "Combi" can be easily changed as with all other measurement places (see Chap. "28.3 Input via Keypad").

40.3 Calculation

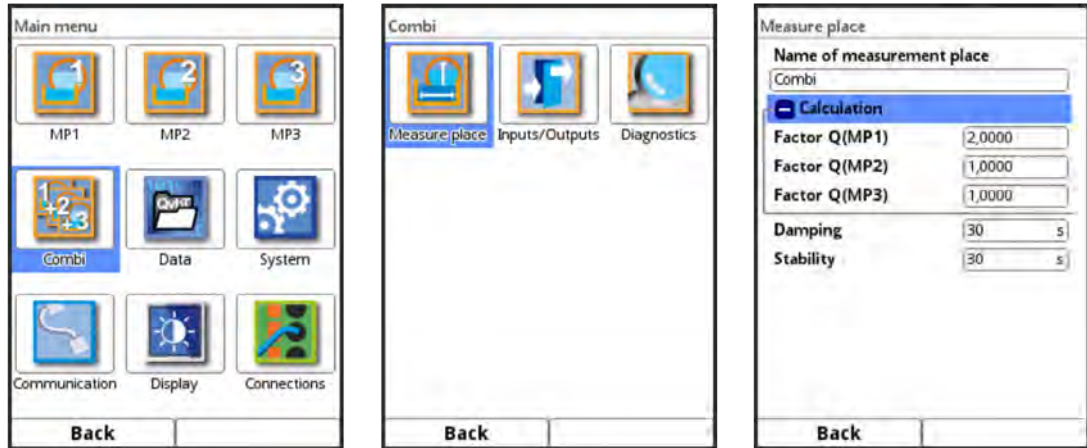

Fig. 40-1 Combi Measurement Place

The **parameterisation of the combi measurement place** essentially consists of defining the **>Calculation<**.

The individual totals of the measurement placed are classified according to the parameterised factors Q in terms of how many percent they should be included into the total flow rate.

$$Q(\text{Combi}) = Q(\text{MP1}) \cdot \text{Factor Q}(\text{MP1}) + Q(\text{MP2}) \cdot \text{Factor Q}(\text{MP2}) + Q(\text{MP3}) \cdot \text{Factor Q}(\text{MP3})$$

The value 1 for **Factor Q(MPx)** means that the total of the respective measurement place is included in the calculation at 100 %.

If the value is less than 1, the corresponding measurement place is included with less than 100 % (0.9 with 90 %, 0.78 with 78 %, etc.), i.e. it is disproportionately lower included in the calculation. A value greater than 1 then means a disproportionately higher influence on the total (higher than 100 %).

If the individual total of a measurement place is to be subtracted, prefix the factor with a "-" (-1).

Application Example:

MP1 = Inlet 1

MP2 = Inlet 2

MP3 = Discharge Total

Inlet 3 to the common measurement place that cannot be measured directly (e.g. due to hydraulic reasons) is to be calculated.

Required calculation:

Inlet 3 = Discharge Total - Inlet 1 - Inlet 2 = MP3 - MP1 - MP2

Factor parameters (all measurement places are included at 100 %):

Factor Q(MP1): -1.0

Factor Q(MP2): -1.0

Factor Q(MP3): 1.0

➡ Procedure for **including inputs/outputs** (using the example of an analogue input) in the calculation of the combi measurement place:

1. Assign analogue input to the combi measurement place under >Main Menu< / >Connections< / >Analogue Inputs<. (see Chap. "45.3 For Transmitters Type M9/G9").

2. Assign the type "Flow" to the corresponding analogue input under >Main Menu< / >Combi< / >Inputs/Outputs< / >Analogue Inputs<.
3. Enter factor Q(AEx) analogue to the factors Q(MPx) of the measurement places.

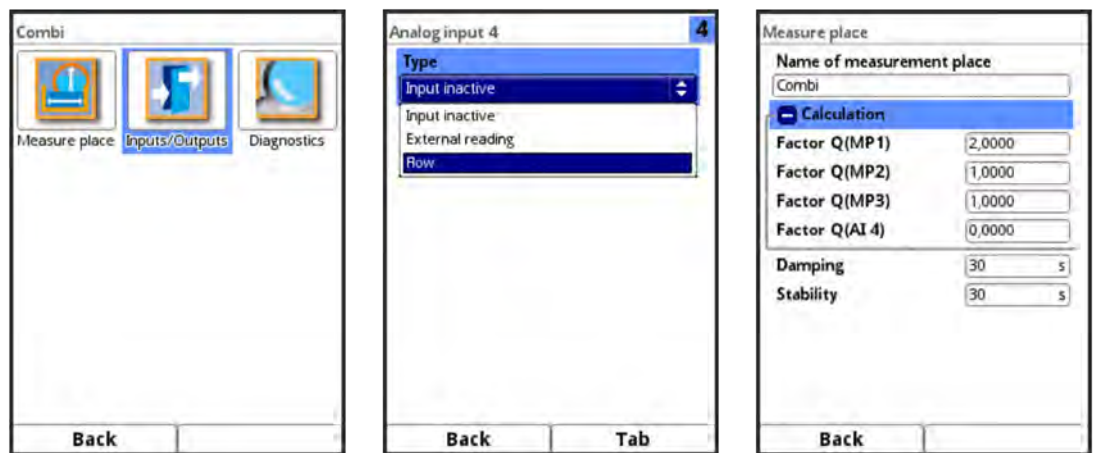

Fig. 40-2 Calculation incl. Analogue Input

40.4 Damping

According to the parameterisation of the damping in the (individual) measurement place under Application.

➡ See Chap. "39.1.7 Damping".

40.5 Stability

According to the parameterisation of the stability in the (individual) measurement place under Application.

➡ See Chap. "39.1.8 Stability".

41 Parameter Menu Data

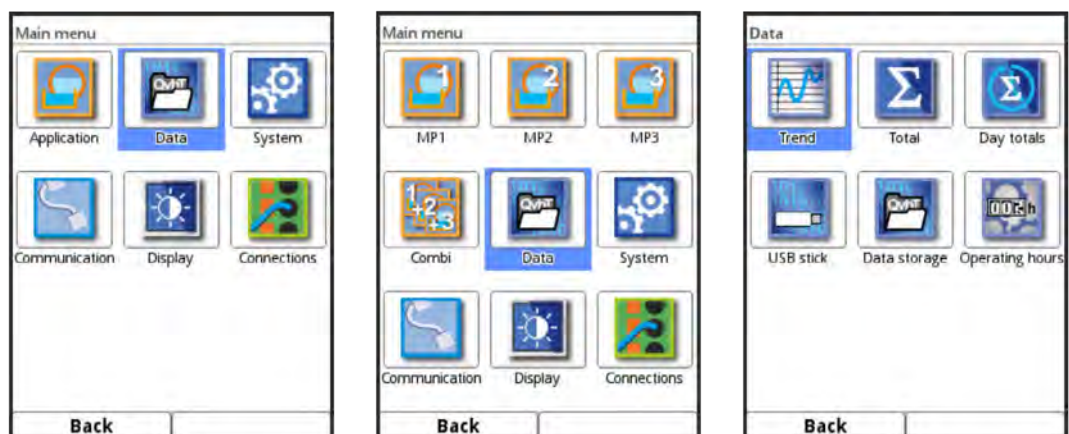

Fig. 41-1 Data Menu

The data menu is primarily a display menu (recorder functions, totals, operating times, etc.). Furthermore, internally stored measurement values as well as the parameterisation of the measurement instrument can be loaded onto a USB stick (to be plugged in).

For the NivuFlow 750 Type M9/G9 with two or three measuring points, the tab key then displayed can be used to scroll between the individual active measurement places.

41.1 Trend

The trend display is a visualising recorder function. When the trend display is selected, the previously stored (historical) measurement data can be accessed.

The individual measurement places of the NivuFlow 750 Type M9/G9 are shown at the top right of the display. Scrolling between the measurement places is possible via the Tab key.

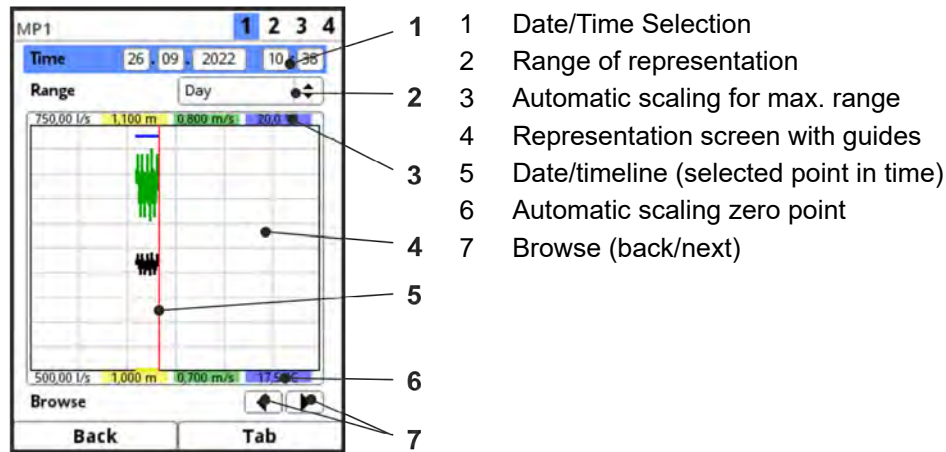

Fig. 41-2 Rerepresentation Trend Graph

Current Measurement Data

➤ Procedure for the representation of current readings:

1. Select the desired range (range of representation; Fig. 41-2 Pos. 2).
The selected range (up to the current time) is displayed. During the display, there is no automatic updating of the measurement data (the current measurement data is shown in the lower third of the main screen).
2. If necessary, use the arrows (Fig. 41-2 Pos. 7) to scroll forwards and backwards with the same basic display setting.
3. Press the left function key ("Back") several times to return to the main screen.

In the top area of the screen you can find the **Date/Time Selection** (Fig. 41-2 Pos. 1). The line is highlighted in blue and is therefore active.

➤ To select a specific point in time (historical measurement data), proceed as follows:

1. Press the rotary pushbutton - the first field (day) is activated.
2. Enter the desired day.
3. Press the rotary pushbutton again - jump to the next field (month).
4. Repeat the entry until the desired time is entered completely (day, month, year, hour, minute).
5. Confirm entry with the right function key. Date and time are adopted.
The display shows the measurement data of the selected date depending on the set time period (Fig. 41-2 Pos. 2).
The red vertical line (Fig. 41-2 Pos. 5) is on the selected point in time (date and time).

➤ To interrupt your input, press the left function key (Back).

Representation:

The selected period is shown from the left to the right edge of the display.

The **Time Period**, in which the data is to be displayed can be changed.

➤ This setting is made using the >Range< (see Fig. 41-2 Pos. 2).

1. Rotate the rotary pushbutton until >Range< is highlighted blue.

2. Press the rotary pushbutton - the selectable time periods become visible.

The choices are:

- (1) Hour
- 4 Hours
- (1) Day
- (1) Week
- 4 Weeks

3. Rotate the rotary pushbutton until the desired range is highlighted blue.

4. Confirm entry with the right function key. The selected range is adopted.

Representation:

Selection	Representation in the Display Area		
	Left Margin	Right Margin	Guides
Hour	0 Minutes	59 Minutes	15 Minutes each
4 Hours	0/4/8/12/16/20 o'clock, depending on the set time	4 Hours later	1 Hour each
Day	0 o'clock	24 o'clock	4 Hours each
Week	Monday, 0 o'clock	Sunday, 24 o'clock	1 Day each
4 Weeks	Monday, 0 o'clock	4 Weeks later, Sunday, 24 o'clock	1 Week each, time reference point for the start: 29.12.1969, 0 o'clock

Tab. 10 Explanation of the periods displayed



Note

For the time period >4 Weeks< it may take a few seconds until the data is completely loaded.

Below the display you can find the **>Browse< function**.

- ➡ Browse forwards or backwards using the arrow symbols: by one selected period unit (Hour, 4 Hours, Day, Week or 4 Weeks) each time the button is pressed.

41.2 Total

The total sums, divided into positive and negative totals, are displayed for the respective measurement places. The total sum is the arithmetical sum of the positive and negative total.

Application Example:

Since commissioning, 10,000 m³ have flowed over the sensor coming from the front. In the same period, 2,000 m³ flowed back from the cable side of the sensor due to backwater.

The display now shows:

- Total 8,000 m³
- Positive total 10,000 m³
- Negative total 2,000 m³

The resettable totals are shown in the bottom area. Their meaning and operation is basically identical to the totals described in the upper section. The resettable totals can, if required, be set to "0" after reading after any period of time via the button **>Reset total<** and count up the totals again from this point on. This makes it easy to determine flow rates between two reading cycles. For security reasons, the reset must be confirmed by entering the password.

With the NivuFlow 750 Type M9/G9 with multiple measurement places, the individual measurement places are shown at the top right of the display. Scrolling between the measurement places is possible via the Tab key.

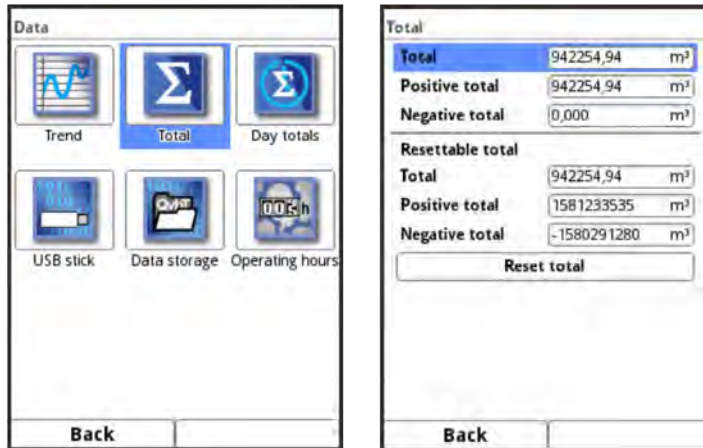

Fig. 41-3 Positive and Negative Totals

41.3 Day Totals

Here, the total flow values or also daily average values can be read in the displayed table. The values are 24-hour values in each case.

The entered update time shows the time at which the value formation takes place daily. This means that the entered value refers to the time range from 24 hours before this date/time to the set date/time.

As per **Default**, the values are always formed at 0.00 o'clock.

With the NivuFlow 750 Type M9/G9 with multiple measurement places, the individual measurement places are shown at the top right of the display. Scrolling between the measurement places is possible via the Tab key.

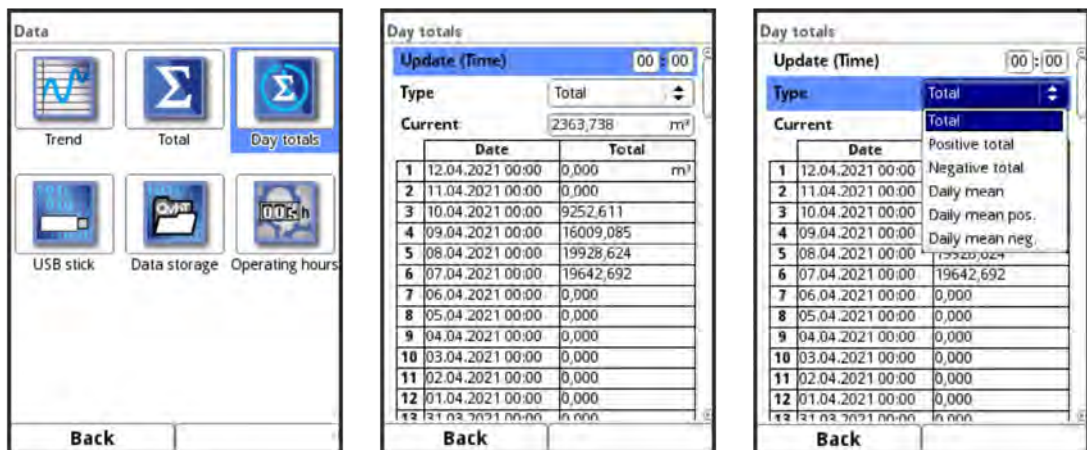

Fig. 41-4 Selecting Day Totals

The representation of the right table column can be changed by means of the setting >Type<. The following display setting options are possible:

- Total: total sums over 24 hrs each
- Positive total: positive totals over 24 hrs each
- Negative total: negative totals over 24 hrs each
- Daily mean: averaged value of the total sum over 24 hours each

- Daily mean pos.: averaged value of the positive total over 24 hours each
- Daily mean neg.: averaged value of the negative total over 24 hours each

Below the button for setting the type, the current daily value is displayed in **>Current<**. This reading will be moved to the first row of the table at the next update time (after 24 hours at the latest).

A maximum of 100 daily values (= 100 days on which a value was recorded) are stored. From value 101 onwards, the oldest value is always overwritten (ring memory).

- Turn the rotary pushbutton to the right to scroll down in the table; to the left to scroll up again.

In this way, older daily values can also be displayed. A prerequisite for the display of older values is that the device has also been running for a longer period of time.

Example: 98 values - The device has been running for 98 days

Generally, only the daily values can be read on which the transmitter was actually in operation. If the transmitter is switched off between two totalising events (< 24 hours), the transmitter calculates a total from the **measured** values. This total does **not** correspond to the **actual** daily quantity that flowed, but to the quantity that the transmitter measured while it was switched on. When determining the daily average values, the "0" values during the switched-off period are included in the calculation.

Example:

There is a constant flow rate of $1,000 \text{ m}^3/\text{h}$. If the transmitter was switched off between 08:00 and 10:00 o'clock, then it measures nothing for two hours. In that case, a total flow rate of $22,000 \text{ m}^3$ is displayed at the end of the day. However, $24,000 \text{ m}^3$ actually flowed. The transmitter has stored a flow rate of 0 m^3 for the duration of these two hours and added it as a valid value to the total flow rate. The daily total does not show that the transmitter did not measure for two hours on this day.

If the transmitter is switched off before the time of the next totalising and then remains switched off until the time of the next totalising (> 24 hours), the transmitter does not calculate a total or an average value for this period of time (see Fig. 41-5). No data is stored and the time period remains unknown. This "gap" can be recognised by the fact that the relevant entry (date/values) is completely missing in the list sequence. No blank lines are shown.

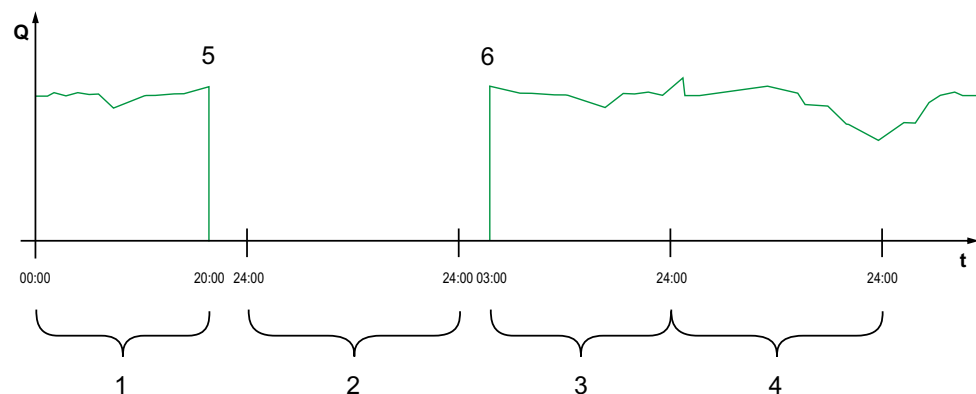

- 1 Total Day 1: total of 20 hours
- 2 Day 2: power failure - no totalising
- 3 Total Day 3: total of 21 hours
- 4 Total Day 4: total of 24 hours
- 5 Power failure
- 6 Power back again

Fig. 41-5 Scheme of Totalising

- The **time** of the totalising is 00:00 o'clock **by default**, but can be changed as described below.

- The factory setting of the time results in the **time period** of the totalising or averaging between 00:00 and 24:00 o'clock. This means that the daily total is always computed between 00:00 and 24:00 o'clock.
- ➡ Changing the time of totalising is done as follows:
1. Rotate the rotary pushbutton until >Update (Time)< is highlighted blue.
 2. Press the rotary pushbutton - the hour section is activated.
 3. Enter the desired start time for the totalising (e.g. 08:00) and turn to the minute section.
 4. Specify the minute value.
 5. Confirm the values with the right >Enter< function key.
The time of totalising is changed to 08:00 o'clock.
This automatically calculates the 24-hour value from 08:00 o'clock to 08:00 the next day.

41.4 USB Stick

Requirements for the USB stick used:

- formatted as FAT 32 (or FAT 12 or FAT 16) (the transmitter cannot read NTFS or exFAT)
- maximum permissible memory size 32 GB (alternatively a larger USB stick that has been "force-formatted" to FAT 32)
- Partitioning table: MBR (GPT currently not supported)

Working with the USB Stick:

- ➡ Plug the USB stick into the slot above the display.

Function:

- Transmission of measurement data to USB stick
- Backing up device parameters to the USB stick
- Retransfer of saved parameters from the USB stick to the device
- Formatting the USB stick

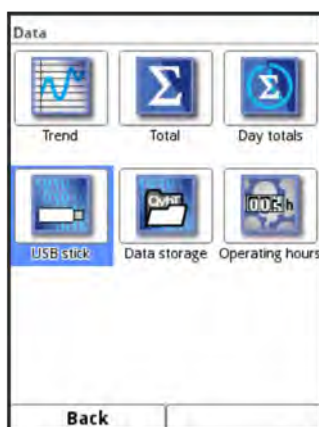

Fig. 41-6 Selection Submenu

The transmitter has an internal data memory. If required, part of the measurement data or all stored measurement data can be transferred to a USB stick.

Per default, the transmitter offers the transmission period since the last data transmission up to the current time. This transmission period can be adjusted, however.

➡ To save data to USB stick proceed as follows:

1. Press the rotary pushbutton - the first field is activated.
2. Turn the rotary-push button to select the day of the desired start time.
3. Press the rotary pushbutton again - now the month can be specified.
4. Repeat the process until the desired date and time have been entered completely.
5. Confirm the start time with the right >Enter< function key.
6. Turn the rotary pushbutton - the field >to< is highlighted blue.
7. Turn the rotary-push button to select the day of the desired end time.
8. Set the end time in the same way as the start time.

This sets the time period for the data to be transferred to the USB stick.

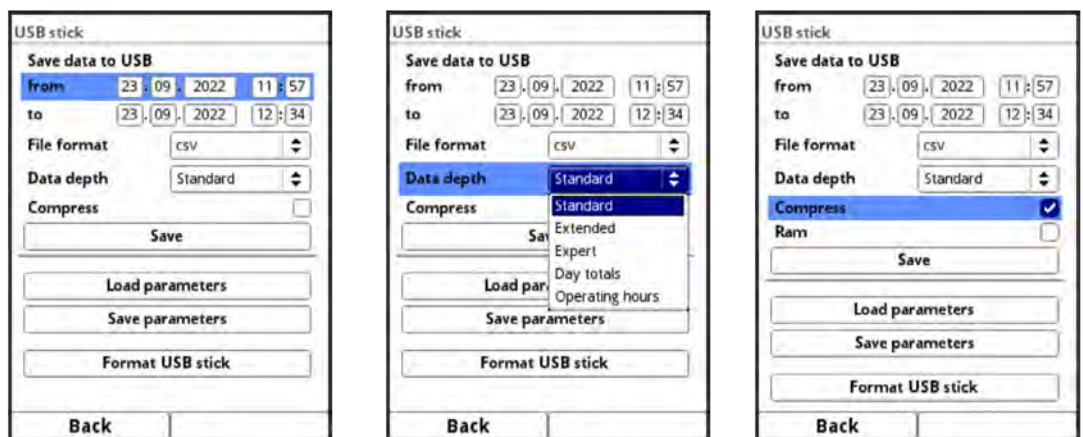

Fig. 41-7 Transmission Period/Data Depth/Compression

9. To select the desired file format, press the rotary pushbutton - a selection menu opens.
The choices are: txt and csv.
10. Press the rotary pushbutton to accept the file format.

The adjustable **data depth** comprises five possible selection ranges:

- **Standard**

This memory format is sufficient for most applications.
The stored records contain the following information:

- Date and Time
- Totaliser
- Calculated Flow Rate
- Level
- Average Flow Velocity
- Water Temperature
- Air Temperature (if an AUS or i-Series sensor is used)
- Current values and the values calculated from them for the activated analogue and digital inputs

- **Extended**

This data set is useful for controlling critical important applications and is mainly needed by service personnel.

The stored records contain the following information:

- All data sets from the previous data depth >Standard<
- Average flow velocities of v-sensors 1, 2 and 3 (if used)
- Trigger and hydraulics qualities of v-sensors 1, 2 and 3 (if used)

- **Expert**

Such data sets should only be activated by specially trained **service personnel** or **developers** of the manufacturer. These data sets can quickly become very large.

- All data sets from the previous data depth >Extended<
- All individual gate velocities as well as all gate positions of all connected v-sensors

- **Day Totals**

The totals saved in the menu >Data< / >Day Totals< as well as the positive and negative totals are stored on the plugged USB stick after selecting and pressing the button >Save<.

- **Operating Hours**

The operating hours per day saved in the menu >Data< / >Operating Hours< are stored on the plugged USB stick after selecting and pressing the button >Save<.

The **>Compress< function** is only useful for transmitting large amounts of data. In this case, the selected files are zipped into the ".zip" format. If this option is checked, **>Ram<** can also be selected and the data is written to the internal Ram memory (approx. 16 MB) instead of a USB stick. The selected, stored data can then be retrieved from this ram memory, e.g. via remote access.

🔄 Once the transfer period, data format and data depth have been defined, save the data to the USB stick.

1. Activate the >Save< field.
2. Press the rotary pushbutton to save the data to the USB stick.

The generated table can contain the following data or information about the data, depending on the data depth set. The units in [] correspond to the default setting, but can be changed if necessary.



Note

The following table contains only the most relevant information. Different content can be displayed depending on the device type and parameterisation.

Unclear or special contents can be requested from the NIVUS customer service (see Chap. "53.2 Customer Service Information").

Name	Data Depth	Meaning
Date	Standard, Extended, Expert	Date of the table entry (time of storage)
Time	Standard, Extended, Expert	Time of the table entry (time of storage)

app1_sum [m³]	Standard, Extended, Expert	Positive flow rate total at the time of storage
app1_q [m³/s]	Standard, Extended, Expert	Flow volume at the time of storage, value calculated by the measurement system
app1_h [m]	Standard, Extended, Expert	Average filling level at the time of storage, value used by the measurement system
app1_a [m²]	Standard, Extended, Expert	Calculated, hydraulically wetted area at the time of storage
app1_v [m/s]	Standard, Extended, Expert	Average velocity at the time of storage, value used by the measurement system
app1_t_water [°C]	Standard, Extended, Expert	Water temperature at the time of storage
app1_t_air [C°]	Standard, Extended, Expert	Average air temperature at the time of storage (only when using an air ultrasonic sensor)
app1_h_pressure [m]	Extended, Expert	Average filling level of the pressure sensor at the time of storage (if used)
app1_h_water [m]	Extended, Expert	Average filling level of the water ultrasonic sensor at the time of storage (if used)
app1_h_air [m]	Extended, Expert	Average filling level of the air ultrasonic sensor at the time of storage (if used)
app1_h_isensor [m]	Extended, Expert	Average filling level of the i-Series sensor at the time of storage (if used)
app1_h_current [m]	Extended, Expert	Filling level at the time of storage at the current input of height sensor 1, scaled measured value of the sensor
p<x>_v [m/s]	Extended, Expert	Average velocity of the sensor <x> (x is placeholder for the sensor number: p1, p2, p3 etc.)
p<x>_v<y> [m/s]	Extended, Expert	Measured flow velocity of sensor <x> in measurement window/gate <y> (y is placeholder for the gate number: v1, v2, v3 etc.)
p<x>_tq [%]	Extended, Expert	Trigger quality, presence of raw values from sensor <x> (depending on reflections)
p<x>_hq [%]	Extended, Expert	Hydraulic quality, measurements outside the histogram filter
p<x>_ntyp [dBμ]	Extended, Expert	Typical noise in the sensor signal
p<x>_nmax [dBμ]	Extended, Expert	Maximum noise in the sensor signal
P<x>_pos1-16 [m]	Expert	Position of the measurement window/gate in the vertical above the bottom
sys_t [°C]	Expert	Temperature within the transmitter

Tab. 11 Information on the Data (USB Storage)

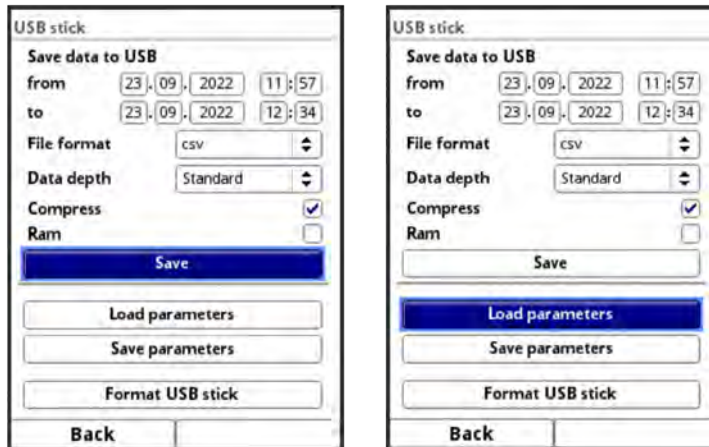

Fig. 41-8 Save/Load Parameters

With the function **>Load Parameters<** a previously saved parameter file can be loaded from the USB stick to the transmitter.

With the function **>Save Parameters<** the set parameterisation of the measurement place can be loaded to the USB stick. Here two files are created and saved.

The files have the following formats:

- **XXXX_DOC_AABBCCDDEE.pdf**
This file is for documentation purposes and can be opened and printed directly using a pdf reader. In the header, it contains information on the transmitter type, date and time of parameterisation, firmware, serial number and article number of the transmitter.
Basic parameter settings such as measurement place description/dimensions, used and parameterised level sensors, used flow velocity sensors in relation to type, installation position, installation height, installation angle etc. are output.
In addition, the display of the parameter settings of analogue and digital inputs and outputs, a possibly parameterised controller incl. its parameters, various system information such as time/date format, country and device settings as well as Modbus and display settings.
- **XXXX_PAR_AABBCCDDEE.xmz**
This file contains the complete parameter set of the transmitter. It is used to save the parameterisation that has been set and can only be read by the device due to the file format.

Information on File Naming:

- XXXX = Name of the measurement place set
- AO = Year
- BB = Month
- CC = Day
- DD = Hour
- EE = Minute

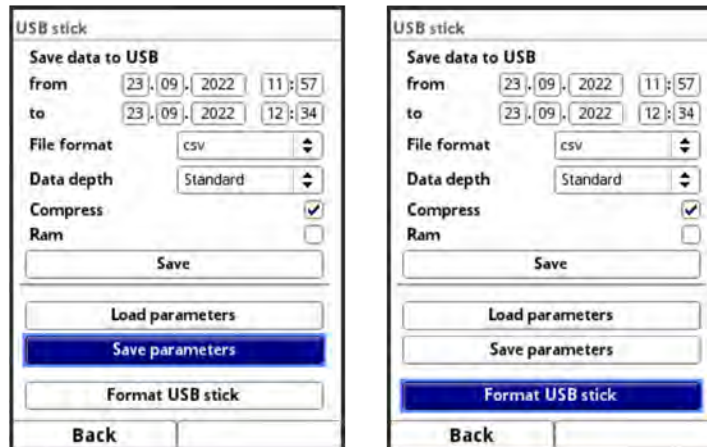

Fig. 41-9 Save Parameters/Format USB

- Unformatted or incorrectly formatted USB sticks can be converted to the correct storage format directly at the device:
 1. Rotate the rotary pushbutton until >Format USB Stick< is highlighted blue.
 2. Press the rotary pushbutton - the plugged USB stick is formatted.
When the USB stick has been formatted, the message >SUCCESSFUL< appears on the display.

41.5 Data Memory (Internal)

41.5.1 Basic Functions

In this submenu you can change the storage cycle and delete the internal data memory.

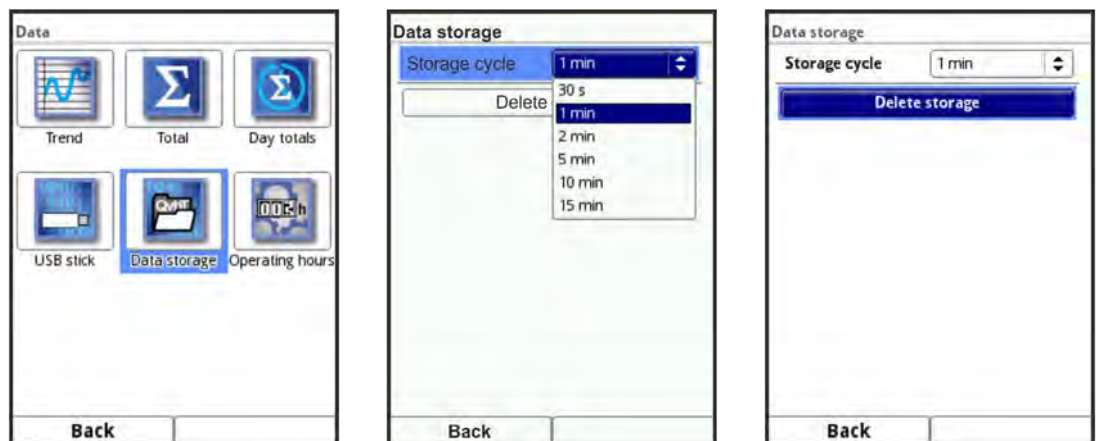

Fig. 41-10 Data Memory

Selection options for the >Storage Cycle< are:

- 30 s, 1 min, 2 min, 5 min, 10 min, 15 min

Default setting for the storage cycle: 1 min

The **average value** over the selected cycle is **always** saved, not the instantaneous value at the time of saving.

By using >Delete Storage< the stored measurement data in the internal data memory can be deleted. The data is password protected to prevent accidental deletion.



Important Notice

Deleted data cannot be restored!

➡ Procedure:

1. Enter the password to delete the data.
2. Confirm password with the right function key >Enter<.

41.5.2 Cycle Mode / Clock Control

The clock control of the transmitter is used in areas where no permanent supply voltage can be provided and therefore the measurement is supplied by 12 or 24 V DC via rechargeable batteries or standard batteries.

In order to reduce energy consumption in this case, it is possible to operate the measurement cyclically.

This means that the transmitter measures for a defined time, stores the measured values internally and then goes into an energy-saving sleep mode (powerdown) in which it neither measures nor displays measured values.

After a parameterised time, the transmitter "wakes up" again, measures and stores the measured values. This cycle repeats in the specified time intervals.

The cycle operation / clock control functionality can either be purchased directly ex works in the "DL" voltage variant or subsequently as an add-on function licence.



See Chap. "18.1 Device Versions" and "18.2 Add-On Function Licences".

When ordered in **voltage variant "DL"**, the transmitter is equipped with a special power supply unit that consumes extremely little energy in idle state. The function is then immediately available.

If the cycle operation / clock control functionality is **ordered at a later date**, it must first be enabled by the operator. The power consumption here is higher than with the "DL" voltage variant due to the design (use of a power supply unit with DC/DC converter).



See Chap. "42.5.3 Feature Unlock".

In cycle mode / clock control, in addition to the contents of the basic functions (see chapter "41.5.1 Basic Functions"), the >Operating Mode< and the >Measurement Duration< can also be set.

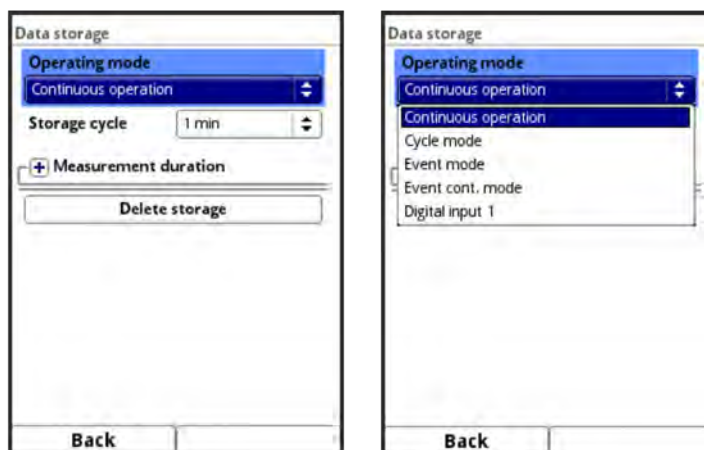

Fig. 41-11 Data Memory Cycle Mode / Clock Control



Recommended Procedure

After completing the parameter settings of the clock control, a test run should ideally take place.

- I. To do this, run the measurement for approx. 3...4 parameterised storage cycles. The display remains dark during this time.*
 - II. After the time has elapsed, wake up the transmitter by pressing the rotary pushbutton.*
 - III. Check the function of the measurement in the parameter menu >Data< / >Trend<.*
-

The selected **>Operating Mode<** determines when and how often the transmitter should take measurements and also save them. Depending on the operating mode, the storage cycle, the event interval and the event type can be set.

The choices for **>Operating Mode<** are:

- **>Continuous Operation<**
The transmitter measures continuously, but stores the measured values only at the intervals of the set storage cycle. The permanently determined individual measured values are averaged internally. The average value of the measured values is saved.
- **>Cycle Mode<**
The transmitter wakes up at the intervals of the set storage cycle, measures for a short time, stores the determined measured values and switches off again automatically ("sleep phase" until the next measurement).
For power-saving reasons, the display remains dark all the time and no measured value is displayed during the measurement cycle.
The transmitter can be woken up for approx. 2 minutes by pressing the rotary pushbutton. If the transmitter is currently in a measurement (in the measurement cycle) at the time of waking up, it takes approx. 5 seconds until the current reading is displayed.
- **>Event Mode<**
The event mode is an extended cycle mode. It has the same parameters and functionality as the cycle mode. In addition, it is possible to switch to the **>Event Interval<** by recognising that a definable measurand has been exceeded or undershot (see Page 153). The measurand that triggers event operation is defined via the **>Event Type<** (see Page 153).
In the event interval the transmitter measures cyclically. The event interval can contain much shorter measuring cycles than the cycle mode. This achieves a better measurement value resolution in important time ranges.

Example:

Measurement of the discharge volume in a discharge channel that is normally dry. Here it is sufficient for the transmitter to measure the value "0" in a storage cycle of 15 minutes and to spend the rest of the time in the sleep phase. If a discharge into the channel is then detected (e.g. using a float switch), the transmitter starts, triggered by the event that occurred, and measures in the set event interval/measurement cycle (e.g. 2 minutes). In the time between measurements, the transmitter goes back to sleep to save energy.



Automatic Change of the Operation Mode

*If the conditions of event operation are no longer given, the transmitter checks this change of state for 5 measuring cycles. If this change of state persists uninterruptedly for 5 measuring cycles (event interval), the transmitter changes from **>Event Mode<** to **>Cycle Mode<**.*

This safety function is intended to prevent constant switching back and forth (e.g. due to sloshing movements, electromagnetic interference or similar).

- **>Event Continuous Mode<**

The event continuous mode and its parameter settings are largely identical to the event mode.

In contrast, the transmitter does **not** switch **off** cyclically in the event interval **during** the event to save energy, but measures in continuous operation. The data is averaged over the entire time span of the event interval and stored in the cycle of the event interval.

The event continuous mode thus consumes slightly more energy than the event mode, but leads to more consistent measurement results for events with strongly fluctuating measured values (e.g. due to waves).



Automatic Change of the Operation Mode

If the conditions of the event continuous mode are no longer given, the transmitter checks this change of state for 5 measuring cycles. If this change of state persists uninterruptedly for 5 measuring cycles (event interval), the transmitter changes from >Event Continuous Mode< to >Cycle Mode<.

This safety function is intended to prevent constant switching back and forth (e.g. due to sloshing movements, electromagnetic interference or similar).

- **>Digital Input 1<**

This function enables the transmitter to be "woken up" from energy-saving sleep mode (powerdown), e.g. by an external data logger with digital output, so that it can carry out a measurement and transfer the measurement results to this external data logger (e.g. via Modbus). A synchronisation between the measurement and the external data logger is triggered by the external data logger.

An inverted or non-inverted reaction can be set via the >Logic<.

The >Cycle< defines how long the external signal must be present to wake up the NivuFlow transmitter. Available are: 1 s, 2 s, 5 s and 10 s

Default setting: 1 s

If the input remains permanently activated, further measurements are carried out in the set storage cycle.



Time stamp atypical due to external triggering

Data is saved when the external data logger is triggered and therefore at atypical times (incoming signal plus measuring time of the measurement system).

The identifiers/time stamps of the data series therefore deviate from the usual system.

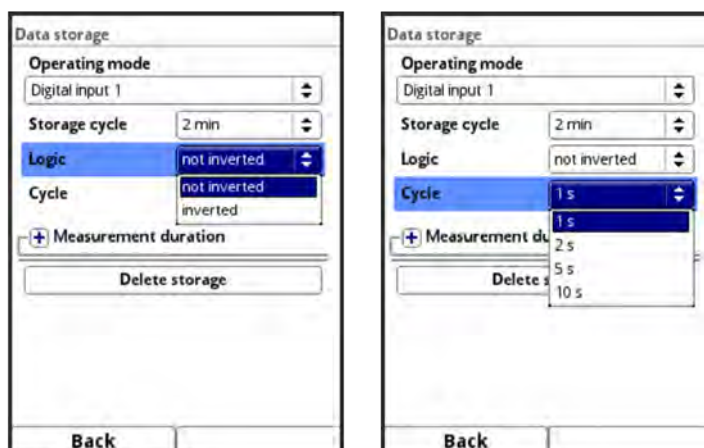

Fig. 41-12 Operating Mode Digital Input 1: Logic / Cycle

Selection options for the **>Storage Cycle<** are:

- with "Continuous operation":
30 s, 1 min, 2 min, 3 min, 5 min, 10 min, 15 min
- with "Cycle Mode", "Event Mode", "Event Continuous Mode" and "Digital Input 1":
1 min, 2 min, 3 min, 5 min, 10 min, 15 min, 30 min, 60 min, 2 h, 3 h, 4 h, 6 h, 8 h, 12 h and 24 h

Selection options for the **>Event Interval<** are:

- 1 min, 2 min, 3 min, 5 min, 10 min, 15 min, 30 min, 60 min, 2 h, 3 h, 4 h and 6 h

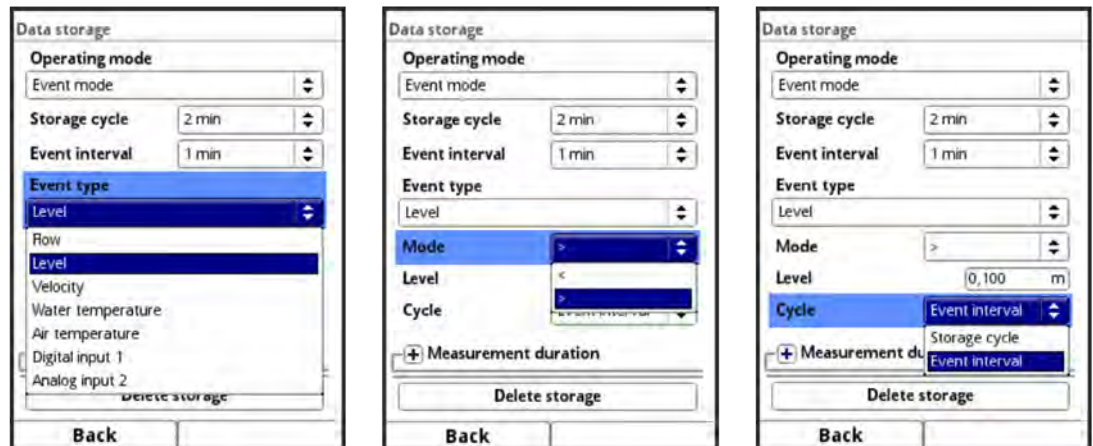

Fig. 41-13 Event (Continuous) Mode: Event Type / Mode / Cycle

>Event Type< (only for Event Mode and Event Continuous Mode)

In the operating modes **>Event Mode<** and **>Event Continuous Mode<**, the event types "Flow", "Level", "Velocity", "Water Temperature", "Air Temperature", "Digital Input 1" and "Analogue Input 2" can be selected.

Info:

For transmitters NivuFlow 750 Type M9/G9 with multiple measurement places, only measuring point 1 is used for evaluation.

- **Flow:**
The transmitter has changed from the sleep phase to the measurement cycle and has determined a valid flow measurement value.
If this measured value is above the set limit value for "Flow", the transmitter switches to event mode and from now on measures in the parameterised event interval until the flow rate falls below the limit value again for 5 measuring cycles.
The recorded measurement values are saved in the **>Event Interval<**.
By using **>Mode<** it is possible to change from overrun to underrun (see Page 154).
- **Level:**
The parameter **>Cycle<** additionally provides to select "Storage Cycle" or "Event Interval".
 - With **"Storage Cycle"**, the transmitter reacts in exactly the same way as described under "Flow", only in relation to the level values.
 - With **"Event Interval"**, the transmitter also wakes up outside of event mode in the event interval, checks the level measurement and switches to event mode if necessary. This allows the transmitter to react more quickly, but consumes more energy.
- **Velocity:**
The transmitter reacts in exactly the same way as described under "Flow", only in relation to the velocity values.

- **Water Temperature:**
The transmitter reacts in exactly the same way as described under "Flow", only in relation to the water temperature.
- **Air Temperature:**
The transmitter reacts in exactly the same way as described under "Flow", only in relation to the air temperature.
- **Digital Input 1:**
Here, a potential-free contact such as a float or pressure switch can be used to switch to event mode in the cycle of the set event interval during the sleep phase. Due to the type of input, very power-saving operation is possible.
- **Analogue Input 2:**
This function uses the possibility of switching to event mode by using an external analogue signal (e.g. exceeding of environmental parameters). The parameter setting options are identical to those for "Level".

>Mode< (only for Event Mode and Event Continuous Mode)

Here it is defined by selecting ">" or "<" whether the event mode starts when the entered value is exceeded or not reached.



Fig. 41-14 Measurement Duration

>Measurement Duration<

- By setting **>Minimum<**, a minimum measurement duration of the transmitter can be defined. The set time indicates the minimum time for which the transmitter is switched on after measurement start. Extending the minimum measurement duration achieves better averaging in the case of fluctuating flow rates. If the minimum value of the measurement duration is set higher than the cycle time (storage cycle), the transmitter goes into continuous mode. In addition, a quality check of the measured values is carried out in the background. This prevents no measurement value or a poor measurement value from being stored if the minimum measurement duration is set too short.
- The **>Maximum<** setting limits the measuring time of the transmitter. It thus prevents the quality check running in the background from not producing satisfactory measurement results in the case of difficult measurements (such as media with few particles and slow flow velocities) and the measurement does not return to the idle state despite cycle mode, but constantly attempts to achieve measurement values. In that case, for energy saving reasons, a "forced shutdown" is carried out and the invalidity marker "#-1" is stored.
- The maximum measurement duration is set to **>Maximum Auto.<** as per default (checked). In this case, the transmitter determines the optimum maximum setting

based on the number of sensors used and activated, analogue inputs and outputs, etc.

If the check mark remains set, the parameter setting is completed and confirmed, then the calculated optimum switch-off time is entered in the >Maximum< parameter after the transmitter has been restarted.

NIVUS recommends keeping the factory setting and not entering a manual switch-off time to avoid invalid readings.

Interaction of cycle operation with other data transmission devices

It is sometimes necessary to transfer the measurement data recorded by the NivuFlow transmitter in cyclical operation to data transmission devices from other manufacturers that also operate cyclically.

There are two options for synchronising the two device cycles via Modbus or analogue outputs:

- 1 The external device wakes up the NivuFlow transmitter for a measurement.
To do this, a signal of at least 1 s duration must be sent from the foreign device to the digital input DI1 of the NivuFlow.
- 2 The NivuFlow transmitter wakes up the external device.
This is done using a digital signal (e.g. from digital output DO1).

As soon as both devices communicate, the NivuFlow transmitter **sends** the measurement data to the foreign device.

Information on Option 1:

To wake up the NivuFlow using a non-system data transmission device, select "Digital Input 1" under >Data Memory< / >Operating Mode< during parameterisation. Under >Logic< you can set whether the input should react inverted or not inverted.

>Cycle< defines the minimum duration for which the external control signal must be present for the NivuFlow to wake up. This serves to prevent external interference signals.

The NivuFlow measures immediately after activation of digital input DI1 and makes its measurement values available via Modbus or analogue outputs. At the same time, it also saves this data in the internal data record. This means that additional measurement data records with "atypical" identifiers/time stamps can be stored there between the storage cycle intervals defined during parameterisation.

If the wake-up signal of the external device is permanently present at DI1, the NivuFlow operates in the set cycle mode until the external signal becomes invalid again.

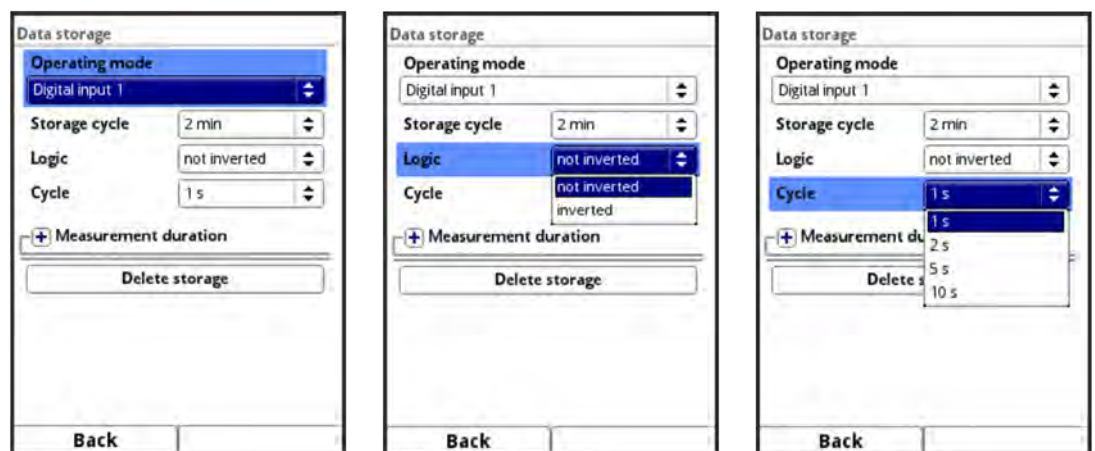

Fig. 41-15 Operating Mode Digital Input 1

Information on Option 2:

If the NivuFlow transmitter is to control a foreign data transmission device via a digital output, select "Measurement valid" for any digital output >Type< under >Application< / >Inputs/Outputs< / >Digital Outputs< during parameterisation.

>Hold< defines the duration for which the NivuFlow transmitter maintains the control signal to wake up the external device.

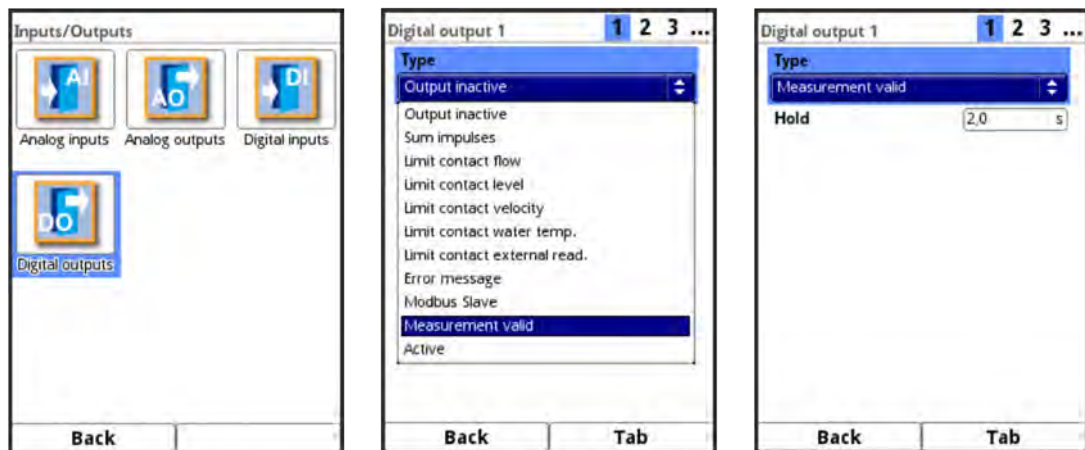

Fig. 41-16 Parameterisation "Measurement valid"

41.6 Operating Hours

Here, the number of total operating hours and the individual daily totals can be read in the displayed table. The table values are 24-hour values in each case.

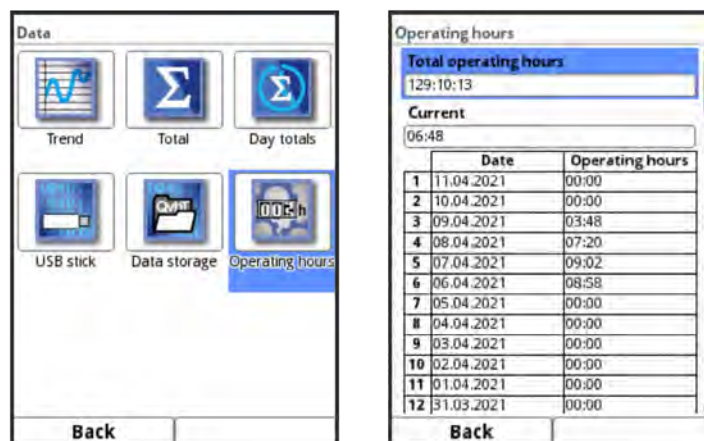

Fig. 41-17 Selection Operating Hours

>Total Operating Hours< shows the total operating time of the system since the supply voltage was applied. It runs continuously when voltage is applied and stops when the power supply is interrupted.

Display format:

xx:yy:zz (days:hours:minutes)

>Current< shows the operating time of the measuring system for the current day.

Below this is a table with the daily totals.

A maximum of 100 total values (= 100 days on which a value was recorded) are stored. From value 101 onwards, the oldest value is always overwritten (ring memory).

- ➡ Turn the rotary pushbutton to the right to scroll down in the table; to the left to scroll up again.

In this way, older values can also be displayed. A prerequisite for the display of older values is that the device has also been running for a longer period of time.

Example: 98 values - The device has been running for 98 days

Generally, only the values can be read on which the transmitter was actually in operation.



Note

The operating hours counter is intended for control purposes and for this reason cannot be reset.

42 Parameter Menu System

42.1 Information

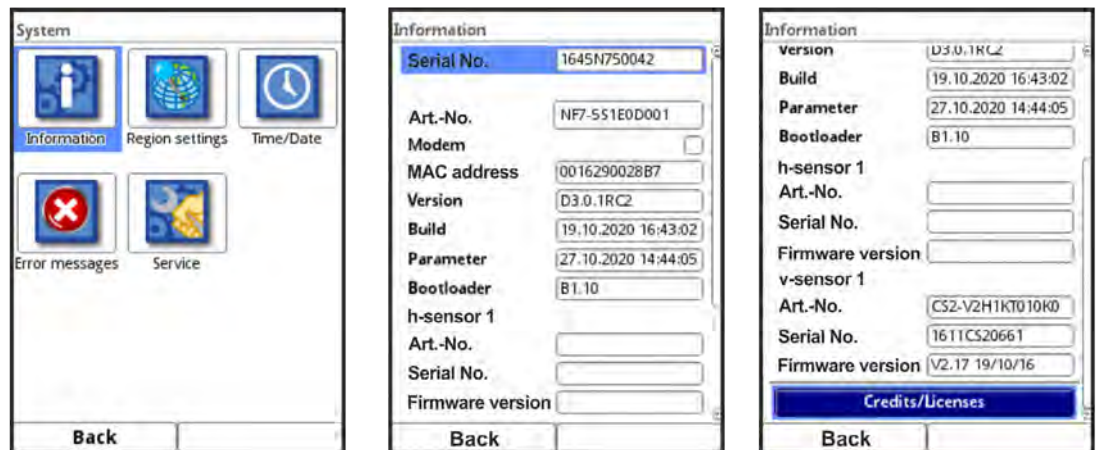

Fig. 42-1 Submenu System/System Information

This menu is a display menu. It contains the following information about the transmitter and the connected sensors and devices:

- Serial number and article number
- MAC Address
- Firmware version
- Specifications on the bootloader and the WLAN version
- Date of the last software update (firmware) and the last parameter storage
- Specifications on connected/activated sensors (serial and article number and firm-ware version)
- Information about Open Source Software used (Credits and Licences)
- Specifications on connected Ex Separation Modules or multiplexers

By pressing the button **>Credits/Licenses<** at the end of the display, the descriptions and links of the open programmes used in the transmitter are saved as pdf to a USB stick to be inserted.



See also Chap. "58 List of Sources of the Licences and Codes used".

This menu is primarily used by the authorised service for (initial) information during commissioning, checking or troubleshooting (on site or by telephone).

42.2 Country Settings

In this menu you can make the following settings:

- (Operating) Language
- Date Format

- Units of the measurement values
A distinction can be made here between the units used in the display and the units used for reading out data.



Fig. 42-2 Region Settings/Language/Date Format

42.2.1 (Operating) Language

All listed languages (Fig. 42-2) provide texts in the national language or the substitute language English.

The current selection is:

- English, German, French, Italian, Spanish, Portuguese, Swedish, Danish, Finnish, Polish, Hungarian, Romanian, Czech, Russian, Korean and Chinese

42.2.2 Date Format

The following date formats can be set:

- DD.MM.YYYY (Day/Month/Year)
- MM/DD/YYYY (Month/Day/Year)

42.2.3 Units

➡ Procedure:

1. Rotate the rotary pushbutton until the field >Units< is highlighted blue.
2. Press the rotary pushbutton - the PLUS at the front turns to MINUS and a selection list opens.
3. Turn the rotary pushbutton to the respective selection field.

Decimal Separator

- Comma
- Dot

The decimal separators entered here are only used for the display of the transmitter.

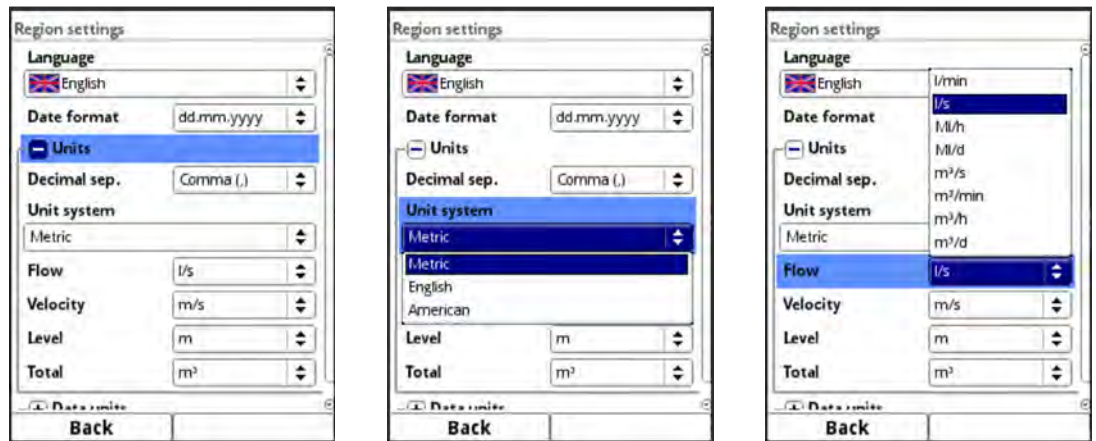

Fig. 42-3 Units System

Units System

The choices are:

- Metric
- English
- American

The adjustable units depend on the selection of the unit system:

- In the metric system - e.g. l, m³, cm/s, m³/min etc.
- In the English system - e.g. ft³, in, ft³/s, Mgal/d etc.
- In the American system - e.g. gpm, in, ft/s, mgd etc.

Units for the representation in the display for

- Flow
- Flow Velocity
- Level
- Total
- Temperature (only in unit system "English")

42.2.4 Data Units

➡ For the setting >Data Units<, proceed in exactly the same way as for the >Units<.

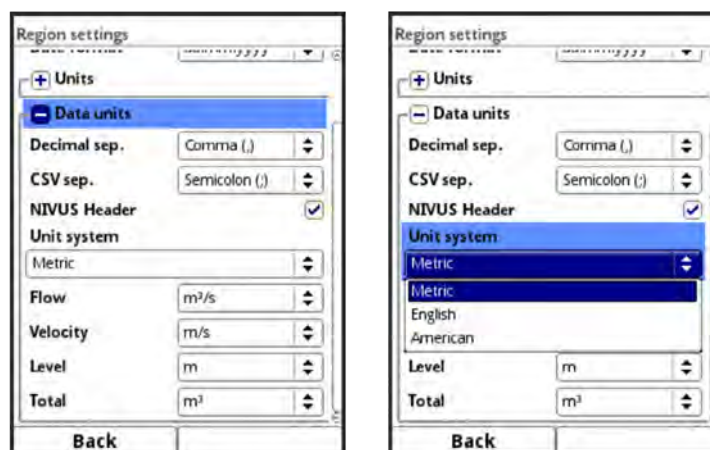

Fig. 42-4 Data Units

The units in which the recorded measurement values are **output** are specified in the **>Memory Units<**.

>Decimal Separator<

- Comma
- Dot

The specification of the decimal separators is important for the correct reading of the data. Especially when evaluating the measurement data with a software in another language (e.g. English Excel), make sure that the decimal separators are correctly selected.

>CSV Sep.< (CSV Separator)

- Comma (,)
- Semicolon (;)

This selection determines how the individual data are separated in the .csv file when reading out the data.

>NIVUS Header<

By checking this box, you can activate the saving of the file header with the name of the measurement place, serial and article number of the transmitter as well as information on the firmware version.

Standard Excel applications as well as the NIVUS evaluation software have no problems displaying this useful additional information. If other programmes have problems reading in or evaluating the data, leave the header switched off.

>Units System<

The choices are:

- Metric
- English
- American

The adjustable units depend on the selection of the unit system:

- In the metric system - e.g. l/s, m³/s, m³/d, cm/s etc.
- In the English system - e.g. ft³/s, in, gal/min, Mgal/d, in/s, yd/s etc.
- In the American system - e.g. gps, gpm, cfs, cfm, cfh, cfd, mgd etc.

Units for the Storage of Measurement Data for

- Flow
- Flow Velocity
- Level
- Total
- Temperature (only in unit system "English")

42.3 Time/Date

In this submenu, the current date and the system time of the transmitter can be changed. The function is needed for the changeover from summer to winter time or after a failure of the internal back-up battery and after a power failure. If the transmitter is operated for a longer period of time, the internal clock may deviate. These deviations can be corrected here.



Note

Changing the system time affects the storage of the data. If data storage is activated, duplicate data or data gaps may occur after system time changes.

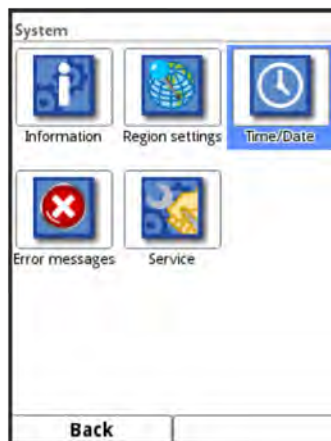

Fig. 42-5 Selecting Time/Date

Setting of the current system time and the time deviation from UTC. In addition, a time server (SNTP) can be configured here. This setting can only take effect with an active Internet connection.



Fig. 42-6 Setup

42.4 Error Messages

In this menu, the current pending error messages and the error memory containing previous errors can be called up. Moreover, the error memory can be deleted.

The data is password protected to prevent accidental deletion.

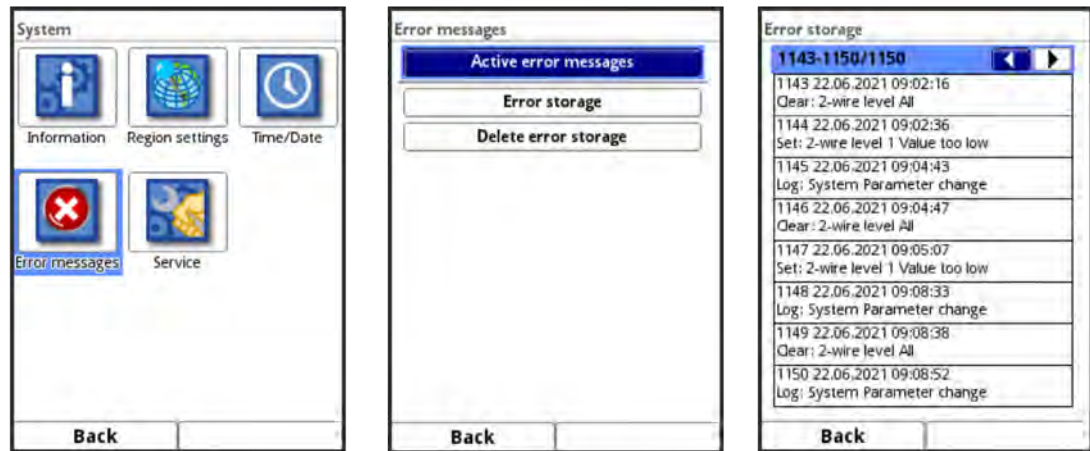

Fig. 42-7 Error Messages

42.5 Service

This submenu contains the following functions:

- Service Level
- Change Password
- Feature Unlock
- Restart (of system)
- Restart Measurement
- Parameter Reset
- Disable coin cell (only for transmitters with modem; Type G1/GR/G3/G9)
- Update NivuFlow (only in service level with password)
- Update v-sensor (only in service level with password)
- Update h-sensor (only in service level with password)

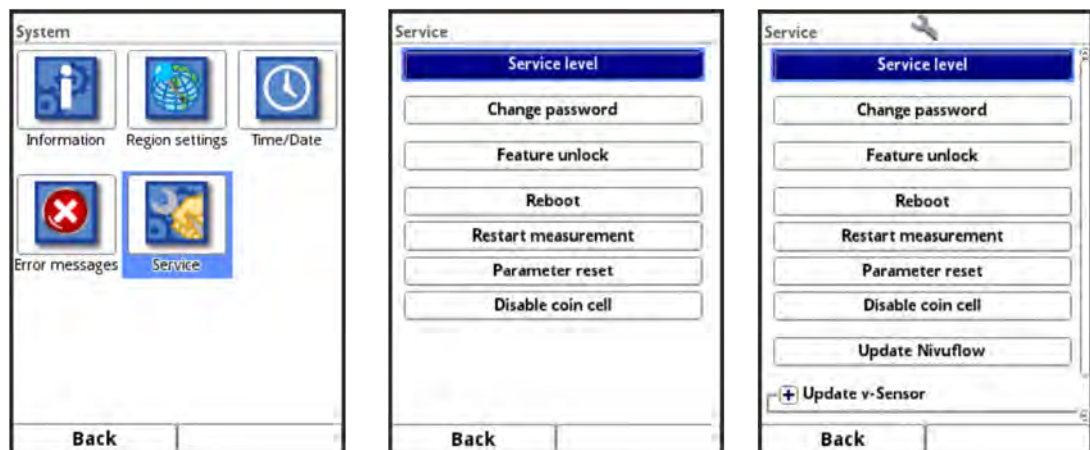

Fig. 42-8 Service

42.5.1 Service Level

Under the service level, which can be activated with the password of the transmitter, additional functions and settings are stored in various places.

The other service levels are reserved for the NIVUS customer service and authorised specialist companies and are therefore also protected with special service passwords.

System-relevant changes and special settings for special applications are set here.

These changes may only be made by the NIVUS commissioning personnel!

42.5.2 Change (System) Password

Default setting of the password: "2718"

NIVUS recommends changing this password to protect the system from unauthorised access. The password can be chosen freely, although it is limited to ten characters.

For your own security, we recommend that you only give your password to **authorised persons**.

A password that you have changed **cannot** be recovered by NIVUS!

If the password is lost, the entire system must be reset, which leads to the loss of set parameters and requires a new parameterisation.

Write down the password and keep the note in a safe place.

➡ See also Chapter "37.2 Change Password".

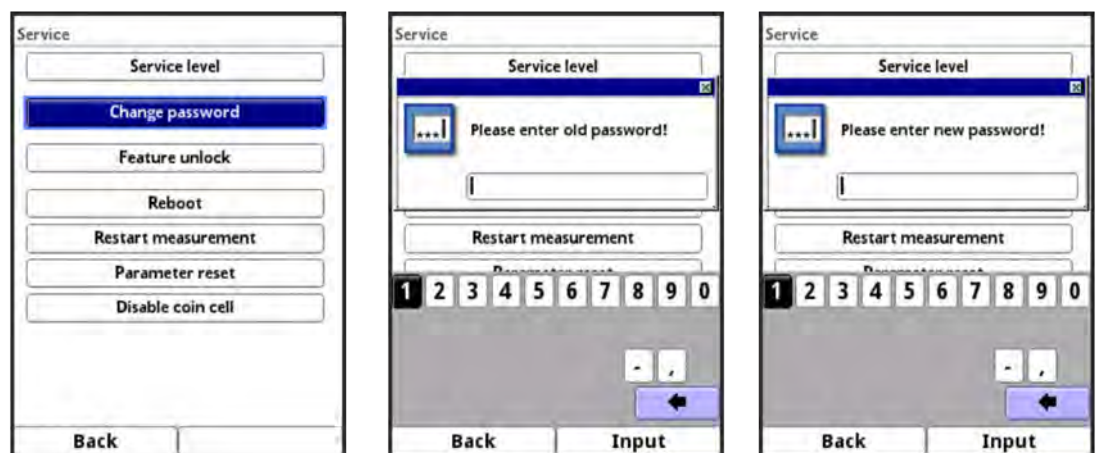

Fig. 42-9 Changing the (System) Password

42.5.3 Feature Unlock

Special (optionally available) functions can be enabled via the feature unlock, provided these have been ordered from NIVUS.



Assignment of the licence to the device unchangeable after being carried out

One licence is only valid for exactly **one device** and is permanently assigned to it through the **serial number**.

This assignment **cannot be changed** or **cannot be undone**.

Before assigning, check exactly which device must/should be linked to which licence so that the correct device also receives the licence and can use this feature.

Always pay attention to the operation of the web interface used (NIVUS WebPortal or customer system).

➡ Procedure for Feature Unlock:

1. Click the >Feature Unlock< button.

2. In the opened menu click the >Feature Unlock< button.
3. Enter the function code and confirm with Input.
4. The transmitter confirms the activation of the function with "Successful". The linked licence is shown in the display.
5. The device requests a restart. Afterwards, the functions are available in the corresponding menus and can be parameterised and used.

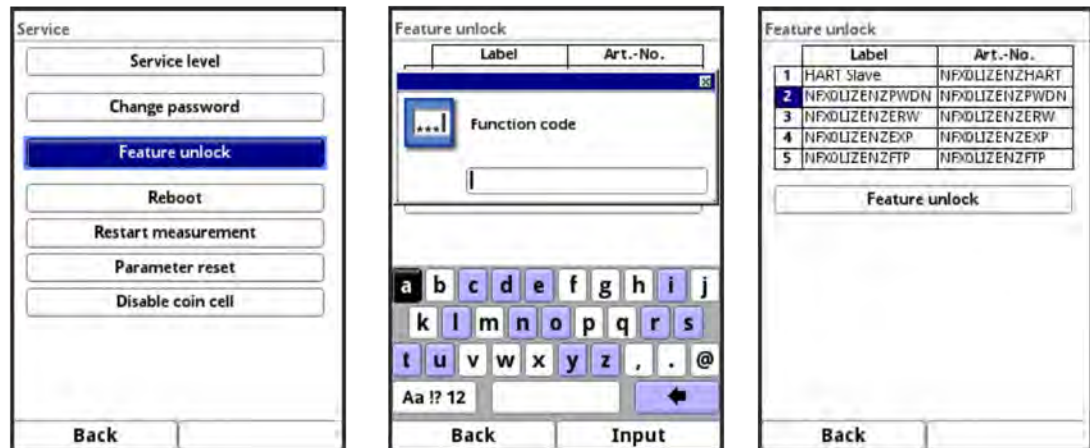

Fig. 42-10 Feature Unlock

42.5.4 Restart

A restart of the transmitter interrupts the current measurement process.

The system boots using the set (saved) parameters. After booting, the system behaves as when it is switched on (analogous to the PC).

This menu point replaces switching the system off and on again. All parameters, counters and stored data are retained.

42.5.5 Restart Measurement

When the measurement is restarted, the currently running measurement is aborted and a new measurement is started.

The transmitter holds the previous display, measurement and output values for the duration of the measurement restart and takes over the new measurement values after the measurement has been restarted successfully.

42.5.6 Parameter Reset

During parameter reset, all parameters are reset to the default settings. Counter readings, changed passwords and stored measurement data are retained in the system.

The actual resetting of the parameters is only carried out after exiting the parameterisation (back to the main menu) and confirming the storage. Until then, the process can still be cancelled.



Fig. 42-11 Resetting the Parameters to Default

42.5.7 Disable Coin Cell

Disables the coin cell (internal back-up battery in the transmitter) to save energy when the transmitter is stored.



Function is not available for all transmitters

This function depends on the hardware status of the transmitter.

➡ Procedure for disabling (including enabling to operate the transmitter again):

1. Click >Disable Coin Cell< and confirm the message with "Yes".
2. Disconnect the unit from the mains within a few seconds (switch off the power) so that the function remains active. If the transmitter is not off the mains power for a short time, it automatically switches the function off again.

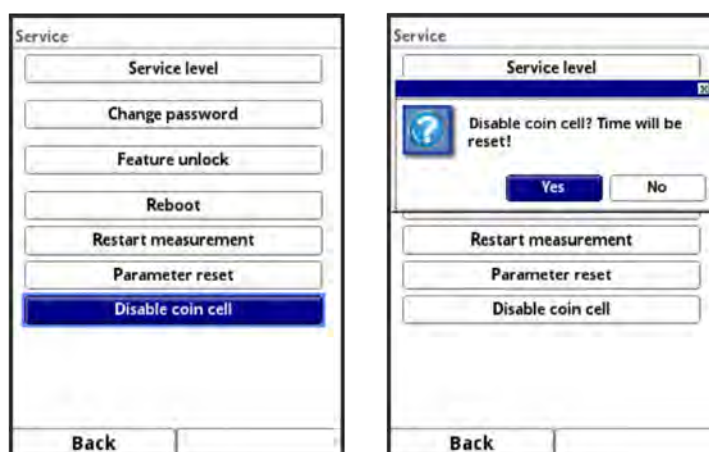

Fig. 42-12 Disable Coin Cell

➡ Procedure for enabling to operate the transmitter again:

1. Connect the transmitter to mains power. The device is initialising.
2. Set the date, time and, if necessary, the time zone according to Chap. "42.3 Time/ Date" and exit.
The transmitter operates normally again.

42.5.8 Update NivuFlow

Upload of a NivuFlow firmware saved on USB.
Access possible in the service level.



Only in consultation with the companies of the NIVUS group

42.5.9 Update v-Sensor

Upload of a sensor firmware saved on USB.
Access possible in the service level.



Only in consultation with the companies of the NIVUS group

It is possible to update all sensors together or only individual sensors.

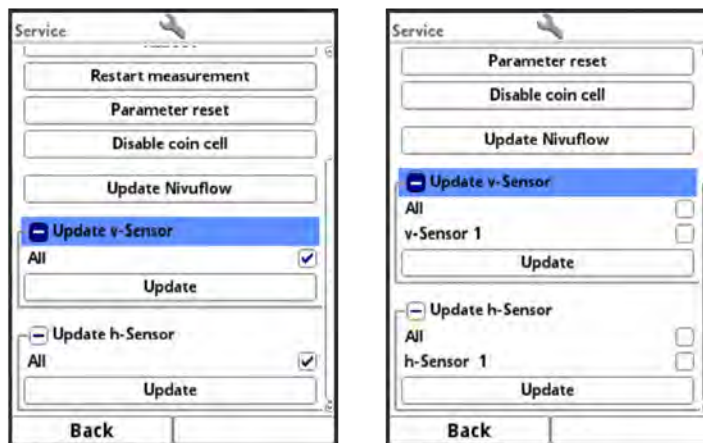

Fig. 42-13 Update v-Sensor (and h-Sensor)

42.5.10 Update h-Sensor

Upload of a sensor firmware saved on USB.
Access possible in the service level.



Only in consultation with the companies of the NIVUS group

It is possible to update all sensors together or only individual sensors (Fig. 42-13).

43 Parameter Menu Communication

In this menu you can establish communication with other devices.

In addition, you can integrate the unit into a network here. Details are only partially described here.

If you do not have the necessary IT knowledge, leave this activity to either an IT specialist or the NIVUS commissioning personnel.

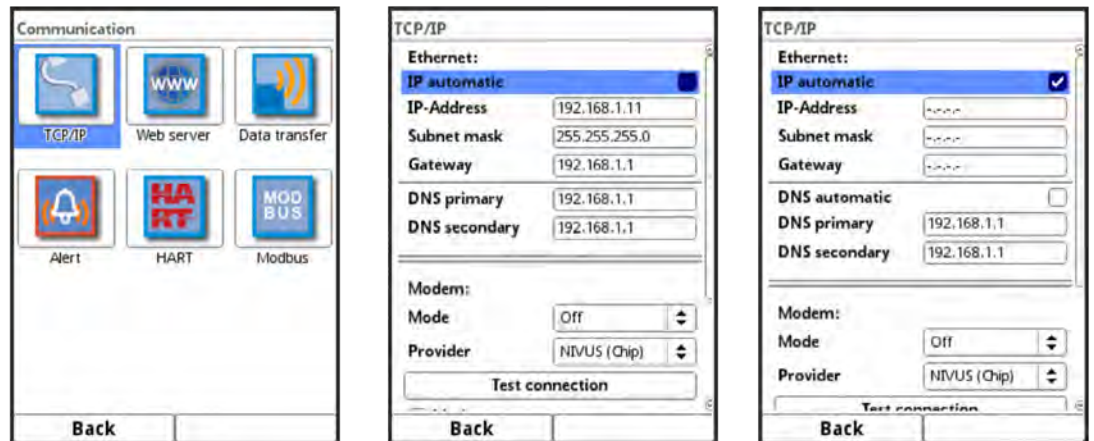

Fig. 43-1 Communication

43.1 TCP/IP

Settings for data transport in a decentralised network. Settings for the IP address and the domain are adjusted here or just displayed.

>IP automatic<:

If activated (check box), the IP address is automatically obtained from the network via DHCP; the addresses are only displayed and cannot be changed by entering them; if the function is activated, the DNS can be automatically selected in the same way.

>IP-Address<:

Address within local network

>Subnet Mask<:

Description of the local network

>Gateway<:

Router address (only if available)

>DNS<:

Addresses of the name servers for address resolution; split into primary and secondary; except if >DNS automatic< is activated, then only primary.

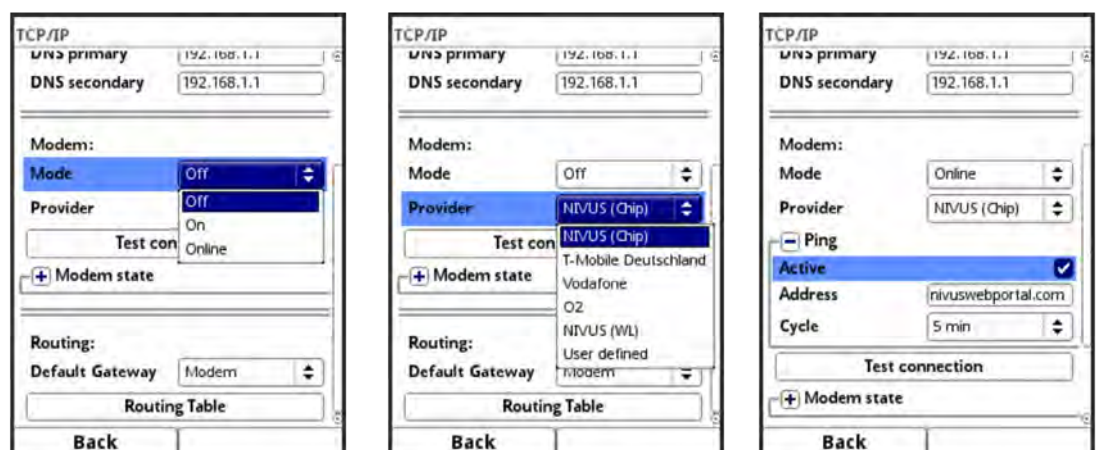

Fig. 43-2 TCP/IP with Modem

>Mode< (only with built-in modem):

Activation of the modem;

Basic status of the modem:

Modem "Off" -

Basic status Off, is switched on when required and goes online.

Modem "On" - Basic status On, goes online when required.

Modem "Online" - Basic status constantly Online.

>Provider (only with built-in modem)<:

The service via which the data connection takes place is selected here. Only one SIM card can be used at a time; there is no dual SIM function.

Currently available: NIVUS (Chip), T-Mobile Germany, Vodafone, O2, NIVUS (WL), user defined.

If "User defined" is selected, the access data of a non-preconfigured provider is entered. If necessary, this information must be requested there.

>Ping< (only with built-in modem):

Activate self-test of the modem (only with modem selection "Online").

>Test Connection< (only with built-in modem):

The modem checks existing connection options.

>Modem State< (only with built-in modem):

The information on the current status of the modem is displayed here.

>SIM Card< (only with built-in modem):

Display of information on the customer's SIM card (not with selection NIVUS (Chip)).

>Default Gateway< (only with built-in modem):

Choice of preferred path of data communication: Ethernet interface or 2G/3G/4G modem.

>Routing Table<:

Data communication in remote networks (WAN) takes place via the >Default Gateway<.

However, if individual remote networks can only be reached via the other interface, this can be entered in the routing table.

43.2 Web Server

The settings required for remote operation of the NivuFlow transmitter are made here. The web server makes all (operating) functions available via the Internet as an alternative to on-site operation.

The access data to the HTTP or FTP web server are defined here. The HTTP server allows remote operation via a web browser, the FTP server allows data transfer via an FTP programme.

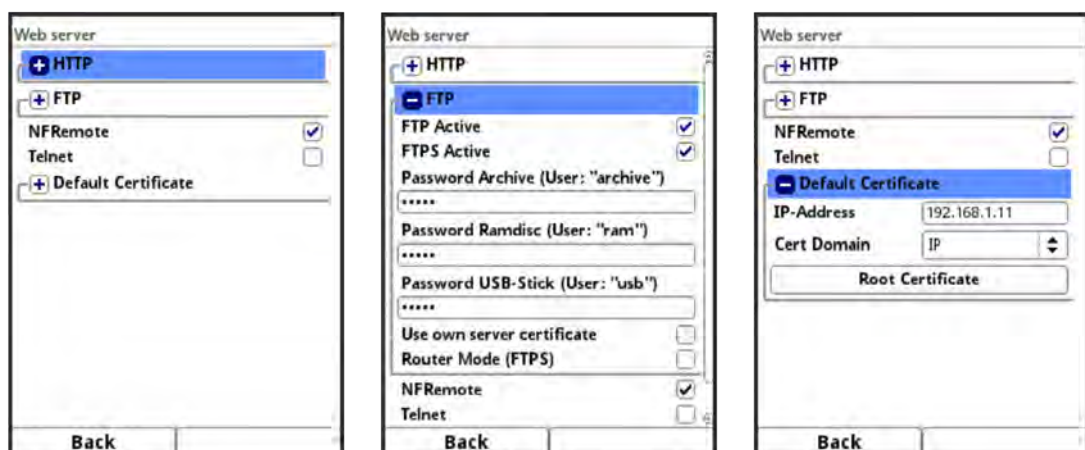

Fig. 43-3 Web Server

HTTP:

- **>HTTP Active<**:
Activation of unencrypted access via port 80
Info:
An unencrypted connection always poses a security risk. NIVUS recommends leaving this option inactive and using HTTPS instead.
- **>HTTPS Active< (Default Setting as of Firmware version 4.4.x):**
Activation of encrypted access via port 443
- **>Username<** and **>Password<**:
Must be set to enable access.
Default setting:
Username: admin
Password: The password is set to an individually determined device ID by default. This ID is attached to the device as a sticker.
Info:
A new, individual password must meet the following criteria:
 - Length of 8-30 characters
 - At least one uppercase letter
 - At least one lowercase letter
 - At least one number
 - At least one special character
- **>Use own Server Certificate<**:
Check box and select file

FTP:

- **>FTP Active<**:
Activation of unencrypted access via port 21
Info:
An unencrypted connection always poses a security risk. NIVUS recommends leaving this option inactive and using FTPS instead.
- **>FTPS Active< (Default Setting as of Firmware version 4.4.x):**
Activation of encrypted access via port 21
- **>Password xxx<**:
Access to the various "drives" via the user name; only parameterisation of the passwords required;
Default setting:
The password is set to an individually determined device ID by default. This ID is attached to the device as a sticker.
Info:
A new, individual password must meet the following criteria:
 - Length of 8-30 characters
 - At least one uppercase letter
 - At least one lowercase letter
 - At least one number
 - At least one special character
- **>Use own Server Certificate<**:
Check box and select file
- **>Router Mode (FTPS)<**:
Check and enter external IP address or corresponding ports (Port Start / Port Num); special FTP mode for TLS via router



The parameter settings in the transmitter and router must match.

NF Remote:

- **>NF Remote<:**
Allow remote access via special application.
Not recommended!

Telnet:

- **>Telnet<:**
Allow remote access via Telnet.
Not recommended!

Standard Certificate:

- **>Standard Certificate<:**
Enter / change the certificate used; enter/select IP address and domain type (IP / name) or load >Root Certificate< from USB stick;
the device has its own certificate, but can load a third-party certificate via the USB port if required.

43.3 Data Transmission

The automated cyclical data transmission to the NIVUS WebPortal is defined here. This can be done via the network protocol MQTT, via FTP server or via e-mail.

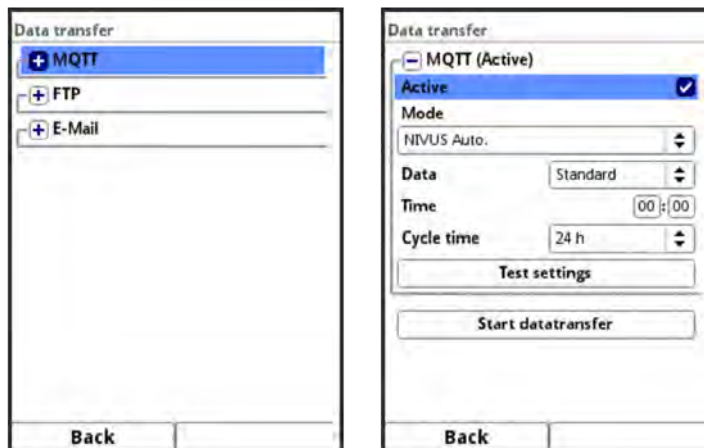

Fig. 43-4 Data Transmission Options / MQTT

MQTT:

The NIVUS WebPortal is pre-configured and available to the user with a chargeable booking. It offers a wide range of options for data display, measurement place visualisation, reporting and analyses.

As an option, the MQTT network protocol is available. This protocol is used to send all data that accumulates in the data memory to an MQTT server.

- **>Active<:**
Check the box to activate.
- **>Mode<:**
 - **>NIVUS Auto.<:**
The system automatically selects whether the data is sent via Ethernet or via the 2G/3G/4G modem.
 - **>NIVUS Ethernet<:**
Transmits data via Ethernet.

- **>NIVUS Modem<:**
Transmits data using the 2G/3G/4G modem.
- **>User Defined<:**
 - >Modem<:**
The MQTT server is reached exclusively via the 2G/3G/4G modem.
 - >Broker<:**
The Internet address of the server is entered either as a host name or IP address.
 - >Port<:**
Associated port
 - >Encryption<:**
Activation of secure (SSL/TLS) communication between client and server and use of the port.
 - >User Name< and >Password<:**
Authentication of the transmitter at the broker.
- **>Data<:**
Determination of the data depth to be transmitted (see also Chap. "41.4 USB Stick").
 - **>Standard<:**
Basic data
 - **>Extended<:**
Extended data package (available only through bookable licences; see Chap. "18.2 Add-On Function Licences")
 - **>Expert<:**
Maximum data package (available only through bookable licences; see Chap. "18.2 Add-On Function Licences")
- **>Time<:**
Specify by how many hours/minutes the transmission should be shifted from the set transmission rhythm (cycle time). Examples:
 - **>Cycle Time< 6 h and >Time< 01:15**
=> Transmissions at: 01:15, 07:15, 13:15 and 19:15 o'clock
But be sure to note: *If the span under >Time< is greater than the span of the >Cycle Time<, the transmissions will still take place in the specified cycle:*
>Cycle Time< 6 h and >Time< 14:00
=> Transmissions at: 02:00, 08:00, 14:00 and 20:00 o'clock.
- **>Cycle Time<:**
Time until next data transmission; Options: 15 min, 30 min, 1 h, 2 h, 3 h, 4 h, 6 h, 8 h, 12 h and 24 h.
- **>Test Settings<:**
Establish a test connection to the server with the specified values.
- **>Start Data Transfer<:**
Manual data transmission since the last transmitted time stamp.

FTP:

Transmission to a customer FTP server or to the D2W data portal.

Available as an additional function licence (see Chap. "18.2 Add-On Function Licences" and "42.5.3 Feature Unlock").

Option is available only when MQTT is inactive.

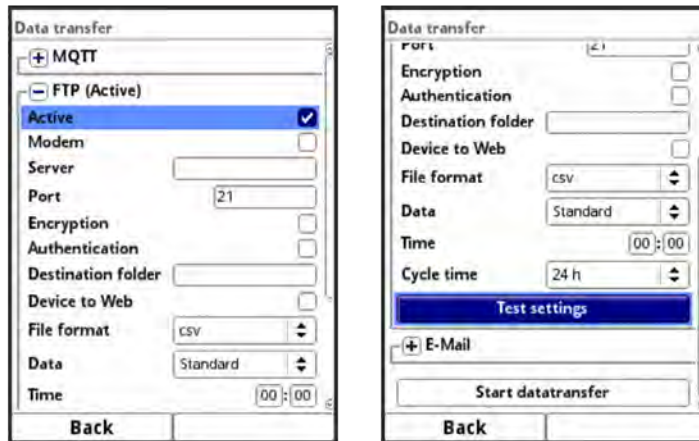

Fig. 43-5 Data Transmission via FTP

- **>Active<:**
Check the box to activate.
- **>Modem<:**
Check box to activate (online) the internal modem before the actual transmission.
- **>Server<:**
Specify server name or IP address.
- **>Port<:**
Associated port
- **>Encryption<:**
Activation of secure (SSL/TLS) communication between client and server.
- **>Authentication<:**
Activate with user and password-protected FTP access and specify in user name and password accordingly.
- **>Destination Folder<:**
Enter the destination folder where the files are to be stored.
- **>Device to Web<:**
Activate when transmitting to the D2W; the Device-to-Web compatible format is applied.
- **>File Format<:**
There are csv and txt available.
- **>Data<:**
Determination of the data depth to be transmitted (see also Chap. "41.4 USB Stick").
 - **>Standard<:**
Basic data
 - **>Extended<:**
Extended data package (available only via additional licences; see Chap. "18.2 Add-On Function Licences")
 - **>Expert<:**
Maximum data package (available only via additional licences; see Chap. "18.2 Add-On Function Licences")
- **>Time<:**
Specify by how many hours/minutes the transmission should be shifted from the set transmission rhythm (cycle time). Examples:
 - **>Cycle Time< 6 h and >Time< 01:15**
=> Transmissions at: 01:15, 07:15, 13:15 and 19:15 o'clock

But be sure to note: *If the span under >Time< is greater than the span of the >Cycle Time<, the transmissions will still take place in the specified cycle:
>Cycle Time< 6 h and >Time< 14:00
=> Transmissions at: 02:00, 08:00, 14:00 and 20:00 o'clock.*

- **>Cycle Time<:**
Time until next data transmission; Options: 15 min, 30 min, 1 h, 2 h, 3 h, 4 h, 6 h, 8 h, 12 h and 24 h.
- **>Test Settings<:**
Establish a test connection to the server with the specified values.
- **>Start Data Transfer<:**
Manual data transmission since the last transmitted time stamp.

E-Mail:

Transmission to an e-mail address.

Available as an additional function licence (see Chap. "18.2 Add-On Function Licences" and "42.5.3 Feature Unlock").

Option is available only when MQTT is inactive.

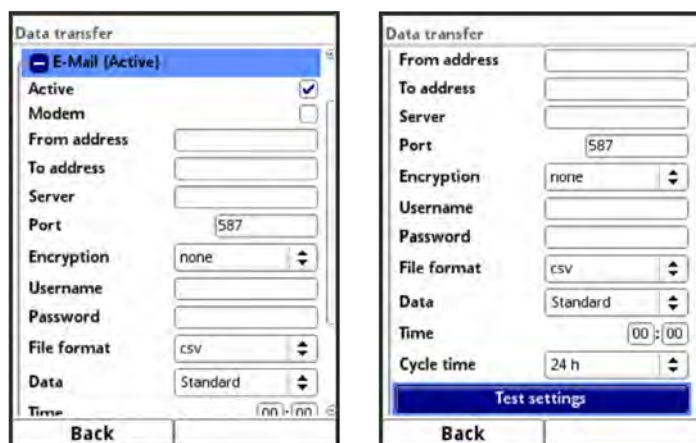

Fig. 43-6 Data Transmission via E-Mail

- **>Active<:**
Check the box to activate.
- **>Modem<:**
Check box to activate (online) the internal modem before the actual transmission.
- **>From Address<:**
E-Mail sender address (needs to be accepted by the SMTP server).
- **>To Address<:**
E-Mail destination address.
- **>Server<:**
Specify server name or IP address.
- **>Port<:**
Associated port
- **>Encryption<:**
An encryption via STARTTLS or SSL can be selected optionally.
- **>User Name<:**
Enter the user name of the e-mail box.
- **>Password<:**
Enter the password of the e-mail box.

- **>File Format<:**
There are csv and txt available.
- **>Data<:**
Determination of the data depth to be transmitted (see also Chap. "41.4 USB Stick").
 - **>Standard<:**
Basic data
 - **>Extended<:**
Extended data package (available only via additional licences; see Chap. "18.2 Add-On Function Licences")
 - **>Expert<:**
Maximum data package (available only via additional licences; see Chap. "18.2 Add-On Function Licences")
- **>Time<:**
Specify by how many hours/minutes the transmission should be shifted from the set transmission rhythm (cycle time). Examples:
 - **>Cycle Time< 6 h and >Time< 01:15**
=> Transmissions at: 01:15, 07:15, 13:15 and 19:15 o'clock
But be sure to note: *If the span under >Time< is greater than the span of the >Cycle Time<, the transmissions will still take place in the specified cycle:*
>Cycle Time< 6 h and >Time< 14:00
=> Transmissions at: 02:00, 08:00, 14:00 and 20:00 o'clock.
- **>Cycle Time<:**
Time until next data transmission; Options: 15 min, 30 min, 1 h, 2 h, 3 h, 4 h, 6 h, 8 h, 12 h and 24 h.
- **>Test Settings<:**
Establish a test connection to the server with the specified values.
- **>Start Data Transfer<:**
Manual data transmission since the last transmitted time stamp.

43.4 Alarm

The >Alarm< parameter menu is divided into various sub-items. These sub-items are >Flow<, >Level<, >Velocity<, >Water Temperature<, >Air Temperature<, >Analogue Input x< and >Digital Input x< ("x" here is a placeholder, the respective number depends on the type-related number of available analogue and digital inputs).

All sub-items are only visible if the analogue and digital inputs have previously been assigned a type under >Application< and thus activated.

➡ See Chap. "39.4.1 Analogue Inputs" and "39.4.3 Digital Inputs".

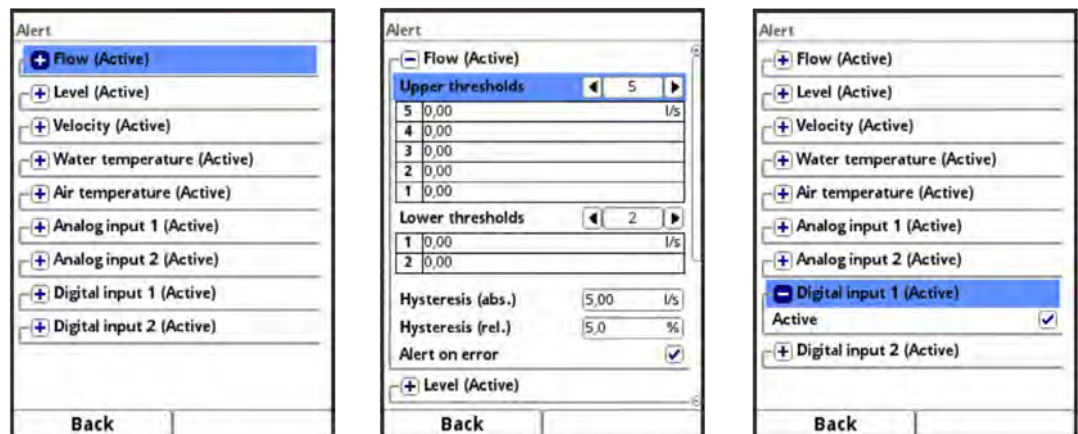

Fig. 43-7 Alarm menu

For all sub-items (except >Digital input<), up to five different threshold values can be entered via the rotary pushbutton for >Upper Thresholds< and for >Lower Thresholds<.

When these are reached, an alarm e-mail (only in connection with the NIVUS WebPortal) is to be issued.

The threshold values are defined by clicking on the fields and typing in numerical values. The transmitter sorts the entered threshold values in descending order. This is done independently of the input sequence.

By specifying >Hysteresis (abs.)< and >Hysteresis (rel.)<, the alarm transmission can be stabilised. To prevent constant status changes due to the smallest fluctuations, the hysteresis function sets a "control threshold" above or below the actual threshold value at a defined absolute or relative distance. Only when this is exceeded or fallen short of, the new change of state is accepted and an alarm transmission (Alarm active/inactive) is triggered.

In addition, the checkbox >Alert on Error< can be set. Then an alarm e-mail (only in connection with the NIVUS WebPortal) is sent in the event of an active pending error. Such errors are e.g. cable faults, interruptions, short circuits etc.



Check >Alert on error< box

NIVUS recommend checking this box to receive an alarm e-mail if a flow velocity sensor is defective. A defect in the flow velocity sensor will cause the flow measurement to fail.

In the sub-item >Digital Input x< a check mark can be set to activate an alarm e-mail (only in connection with the NIVUS WebPortal) when an "active" condition occurs at the digital input.

Default setting: box unchecked.

43.5 HART

The communication via HART (via AO1) functionality must be purchased directly ex works in the extension variant "1".

➡ See Chap. "18.1 Device Versions".

When **ordering in firmware extension variant "1"**, the transmitter is connected according to a special wiring diagram. The function is then immediately available.

The display shows the identification data of the connected transmitter.



Fig. 43-8 HART



Later "installation" of communication via HART (AO1)

If subsequent HART communication of analogue output 1 is required, the corresponding transmitter must be retrofitted at the NIVUS headquarters in Eppingen (replacement of circuit boards).

Contact NIVUS in Eppingen for a retrofit offer.

Have the article/serial no. of the affected transmitter ready.

43.6 Modbus

The transmitter can be integrated into other systems via Modbus.

If required, the NIVUS Modbus TCP/RTU technical description (see Chapter "1.1 Applicable Documentation") can be sent to you on request. For this purpose, please contact the technical office staff at the head office of NIVUS GmbH in Eppingen.

Alternatively, the document is available for download in the download centre on our homepage.

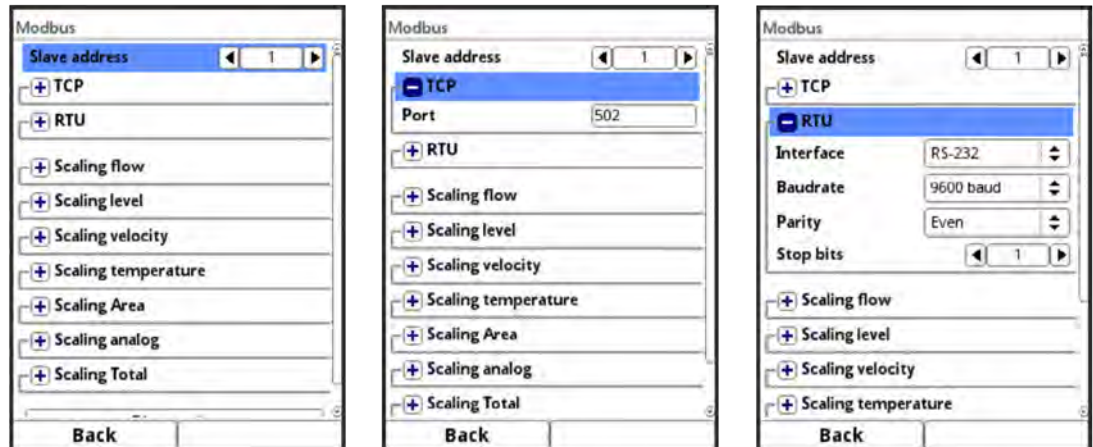

Fig. 43-9 Modbus

The following setting options are available here:

- Slave address (1 to 247 or 255)
- TCP (Port)
- RTU
 - Interface (RS232 or RS485)
 - Baud rate (1200, 2400, 4800, 9600, 19200, 38400, 57600 or 115200 Baud)
 - Parity (None, Odd or Even)
 - Stop bits (1 or 2)

Furthermore, the following scalings can be set:

- Scaling Flow
- Scaling Level
- Scaling Velocity
- Scaling Temperature
- Scaling Area
- Scaling Analogue
- Scaling Total

By entering the values for 0 / 65,535 digits (or -32,768 / 32,767 if Signed is ticked), the resolution of the measuring range is set.

A value must be entered for "Error Value (digits)" (factory setting: "0") in order to communicate an error message when an error occurs.

Under >Scaling Total< only one value is entered for "Scaling/digit".



Expert knowledge required

These settings require extensive expert knowledge and require the use of NIVUS commissioning personnel or an authorised specialist company.



Fig. 43-10 Setting Parameters Scaling / Diagnostics / Serial Stats

Under **>Diagnostics<** the individual registers (flow reference, total reference, flow, level, velocity, water temperature and air temperature) can be viewed in more detail.

The **raw value** and the assignment of the Modbus registers are displayed at the same time. Fixed values can be entered to adjust the scaling/transmission sequence between the transmitter and the connected Scada/PLC.

The statistics (Serial Stats, Frame Stats and Application Stats) are arranged in layers. After viewing, a reset is possible in each case.

Serial Stats concern the serial interfaces (not when accessed via Modbus TCP) and inform about the number of bytes received, sent and discarded/lost.

Frame Stats are about the communication frame and inform about error sources such as the sequence of bytes, checksums, parity, valid packets and other errors.

The **Application Stats** concern the application level and inform about functional errors such as unsuccessful transmissions, unsupported function codes, unoccupied data addresses and other errors.

44 Parameter Menu Display

The following changes can be made for the main display in the display menu:

- Backlight (intensity)
- Lockscreen, Dim backlight and Switch off display (period until switch-off)
- Advance Main Display (only for NivuFlow 750 Type M9/G9 with multiple measurement places)
- Name of the five display fields of the main display
- Decimal places of the individual value representations

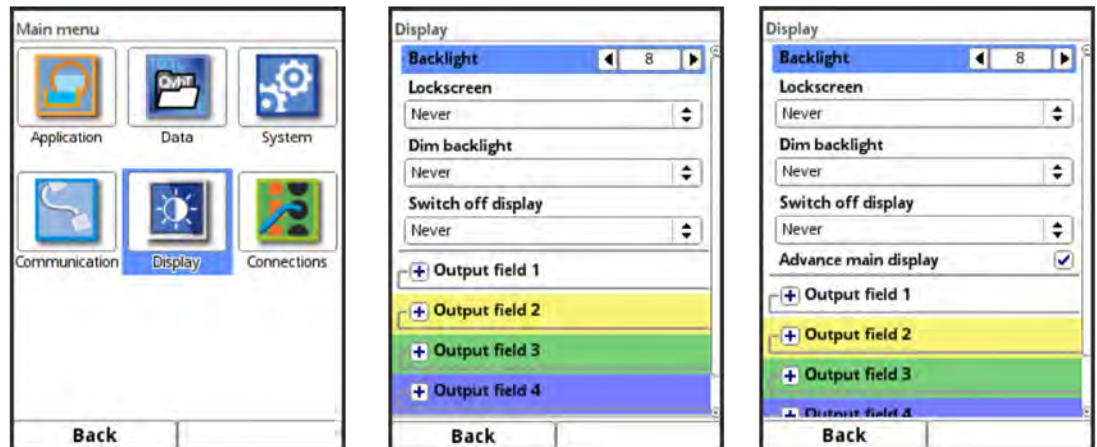

Fig. 44-1 Display/Backlight/Delay Time

Backlight

You can change the backlight in ten levels.

Adjust the backlight to the ambient conditions. Avoid setting the display too bright.

NIVUS recommends setting the automatic display dimming / **Dim backlight** or display switch-off here to protect the display and extend its service life.

The display switches off automatically if you have not used it for a certain time. You can define this time via the delay time / **Switch off display** (Never, 30 s, 1 min, 2 min and 5 min).

As soon as you make any setting on the transmitter (e.g. press a key), the display immediately switches back to the standard brightness.

If you want to ensure that the transmitter display can only be reactivated by authorised persons, use the **>Lockscreen<** function. Then the password for the transmitter must be entered before the display can be used again.

Default settings: >Backlight< on level „8“, >Lockscreen<, >Dim backlight< and >Switch off display< = "Never".

Advance Main Display (only for NivuFlow 750 Type M9/G9 with multiple measurement places)

If the box is checked here, the main display automatically switches back and forth between the activated measuring points for Type M9/G9 with multiple measurement places. Each measurement place or its current values are displayed for approx. 5 s without further settings.

If the check mark is not set, the main display remains at the last measurement place displayed. By pressing the tab key, the display can be advanced to the desired measurement place. The measuring point to which the displayed values apply is indicated in the main display by the measurement place name in the upper left corner or the dark number in the upper right corner (in "tab mode"):

- 1 = Measurement Place MP1
- 2 = Measurement Place MP2

- 3 = Measurement Place MP3
- 4 = Combi Measurement Place

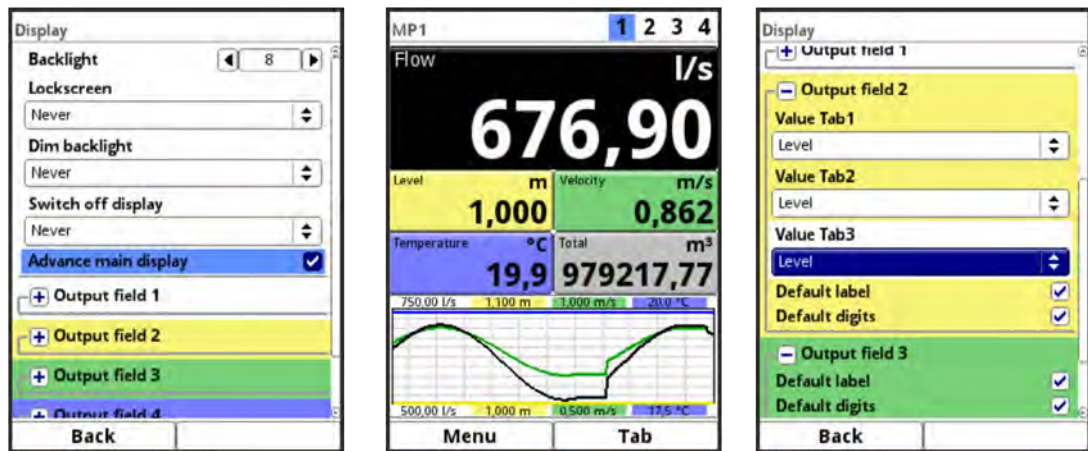

Fig. 44-2 Advance Main Display / Output Fields: assign value

Output Fields

The output fields 1...5 of the main display (flow, level, (wetted hydraulic) surface, analogue output X, medium temperature, air temperature, totals, daily average level, velocity, temperature and total) can be freely defined in terms of designation and decimal places.

For the output fields 2, 4 and 5, you can also select under >Value< which value should actually be displayed.

The options are:

- Output field 2:
"Level", "Area" (= calculated, hydraulically wetted area of the application), "Analogue input 1", "Analogue input 2" (etc.; depending on type and number of AIs) and "Not active"
- Output field 4:
"Area", "Water temperature", "Air temperature" (only possible when using an air-ultrasonic sensor, type LUS), "Total", "Total positive", "Total negative", "Daily average", "Daily average pos.", "Daily average neg.", "Analogue input 1", "Analogue input 2" (etc.; depending on type and number of AIs) and "Not active"
- Output field 5:
"Area", "Total positive", "Total negative", "Daily average", "Daily average pos.", "Daily average neg.", "Analogue input 1", "Analogue input 2" (etc.; depending on type and number of AIs) and "Not active"

Special feature when using a NivuFlow transmitter 750, **Type M9/G9 with multiple measurement places**: here, the display can be set separately for each measurement place MPx.

To do this, open the pull-down menus of the individual output fields at >Value Tab1<, >Value Tab2<, >Value Tab3< and >Value Tab4< and select the desired designation.

The respective "TabX" corresponds to the number at the top right of the main display when advancing is activated.

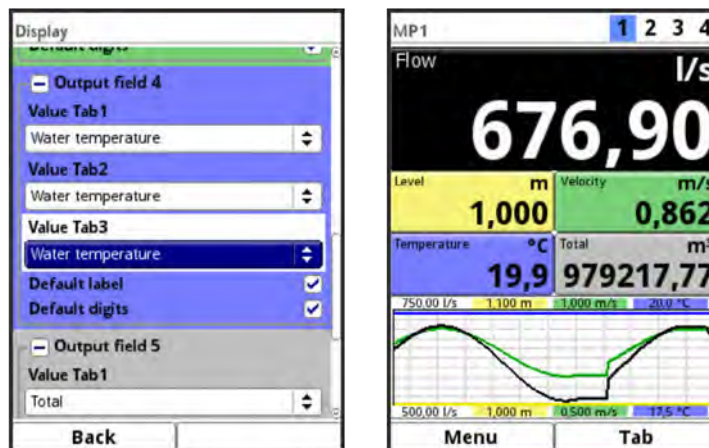

Fig. 44-3 Define Output Fields in case of Multiple Measurement Places / Main Display



Note

The assignment of the values to the fields can NOT be changed in output fields 1 and 3. The change can only be made in the output fields 2, 4 and 5 by selecting "Value" or "Value TabX".

Example: The flow rate is ALWAYS output in the flow field (output field 1), even if you have changed the designation to "Temperature".

The highlighted colours of the output fields correspond to the colours of the values in the main display.

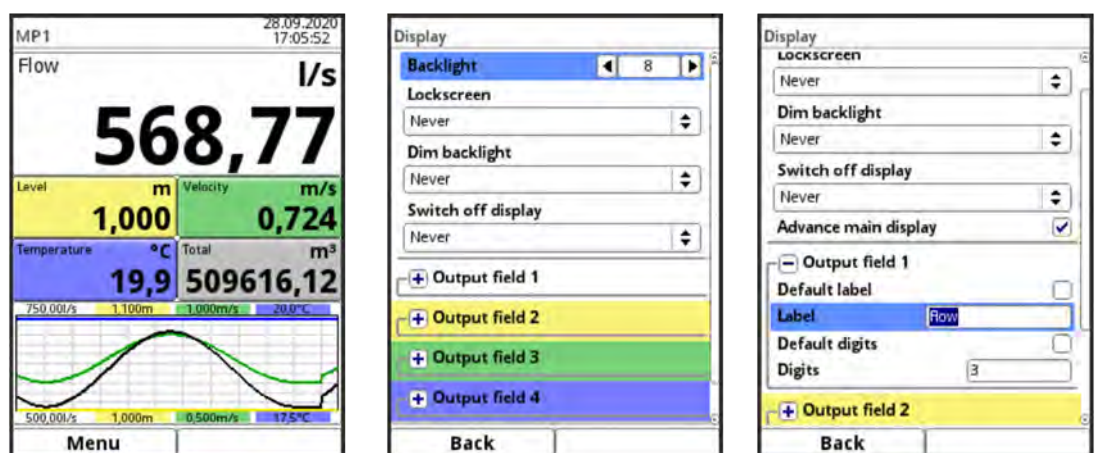

Fig. 44-4 Change Output Fields, Colours and Designation

➡ Procedure to **change the name**:

1. Expand the output field.
2. Uncheck the >Default Label< box.
3. Enter a new name. This designation is freely selectable up to a maximum of 16 characters.
The new name enter does **not** change the value of the fields in the main display.
4. Go "Back" several times to save the parameters.



To save see Chapter "37.1 Save Parameters".

➤ Procedure to **change the number of decimal places**:

1. Expand the output field.
2. Uncheck the >Standard Decimal Places< box.
3. Specify the new number of decimal places.
Any numbers can be entered, but only up to a maximum of five decimal places are accepted.
4. Go "Back" several times to save the parameters.



Observe the measurement accuracy of the sensors

When setting the decimal places, observe the measuring accuracies of the sensors and the set units of measurement.

The temperature sensor, for example, can only resolve in a 0.1 K grid.

45 Parameter Menu Connections

45.1 General

This submenu is required

- if sensors are not connected directly to the transmitter but via the Ex Separation Module Type iXT or the multiplexer MPX or
- for transmitters with multi-measurement place capability to assign the flow velocity sensors and inputs/outputs to the individual measurement places.

45.2 For Transmitters Type S1/G1/SR/GR/M3/G3

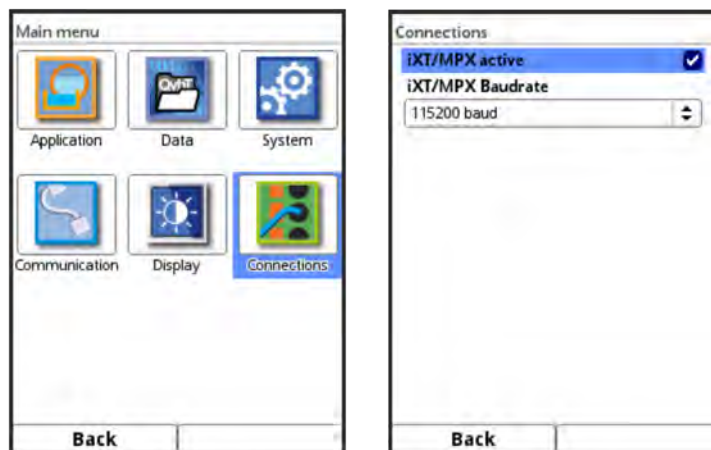

Fig. 45-1 Selecting Connections / Activation / Baud Rate

Check the box when using iXT or MPX together with Types S1/G1/SR/GR/M3/G3. Otherwise the sensor and iXT/MPX will not be recognised by the transmitter.

45.3 For Transmitters Type M9/G9

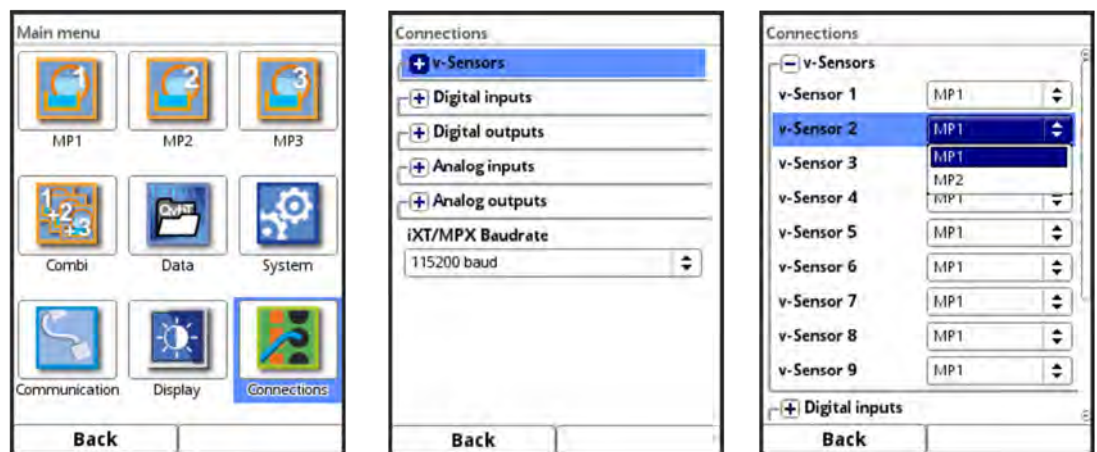

Fig. 45-2 Assignment with NivuFlow 750 Type M9/G9

For NivuFlow 750 Type M9/G9 transmitters with multiple measurement places, the individual flow velocity sensors (v-sensors) and the inputs/outputs must be assigned to the respective measurement places. The prerequisite for this is that the measurement places have been activated before (tick >Active<).

When **assigning the flow velocity sensors**, there is a fixed sequence that must be followed. The assignment always starts with v-sensor 1 and is done in ascending order.

Application Example:

v-sensors 1, 2, 3 and 4 to measurement place MP1

v-sensors 5 and 6 to measurement place MP2

v-sensors 7, 8 and 9 to measurement place MP3

Here it is not possible to assign the higher numbered sensors to a lower numbered measuring point: v-sensor 8 or 9 to MP1 or 2 is not possible.



See also Chap. "25 Special Functions of the NivuFlow 750 Type M9/G9".



Procedure:

1. Open the >Connections< menu.
2. Expand >v-Sensors< and assign them, starting with v-sensor 1, from top to bottom to the respective measuring point MPx.
To avoid incorrect parameter settings, it is only ever possible to select the (numerically) next higher measuring point. If a v-sensor (in the following example v-sensor 5; Fig. 45-3 screens 1...3) is assigned to measurement place MP2, after confirmation all subsequent sensors are immediately also set to measurement place MP2 and can now alternatively only be assigned to measurement place MP3. If this is carried out with v-sensor 7 - as shown in the following example (Fig. 45-3 screens 4...5) - v-sensors 8 and 9 are also automatically set to measurement place MP3 and can no longer be assigned to any previous measurement places.

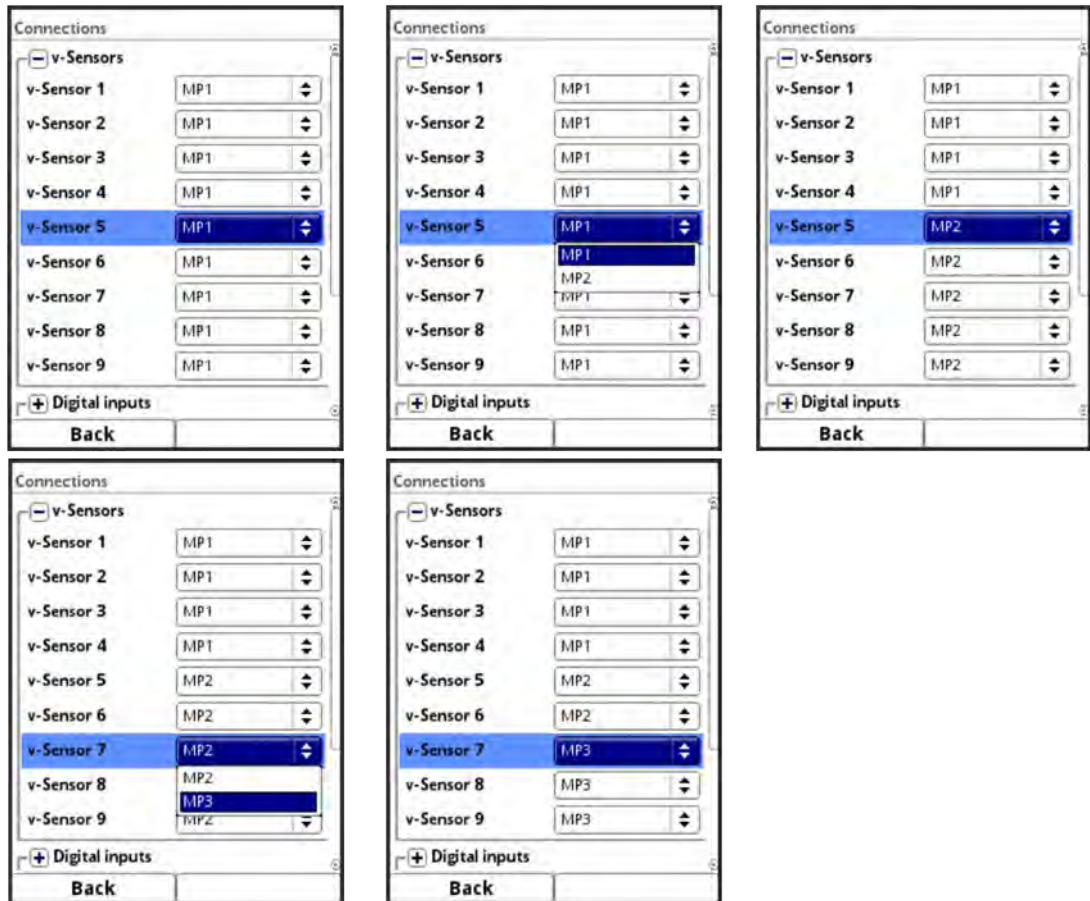
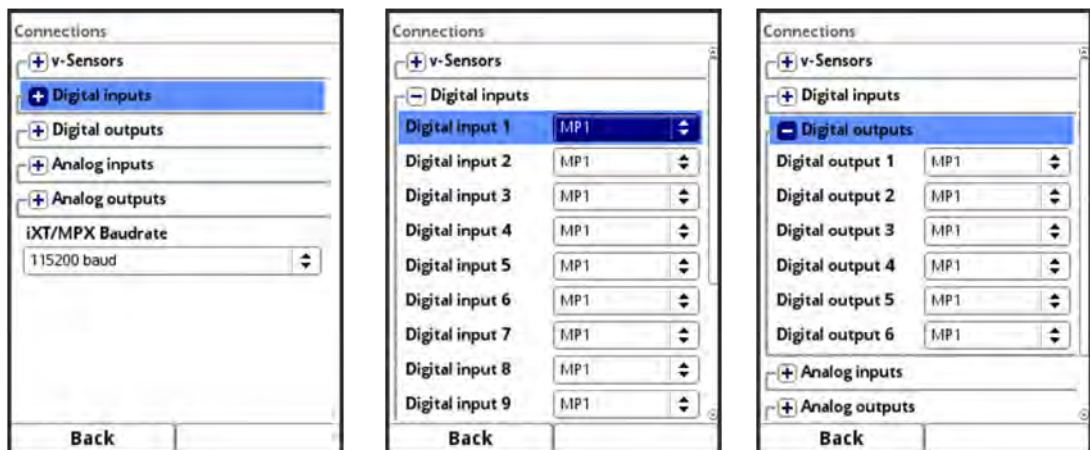

Fig. 45-3 Assignment Examples v-Sensors

When **assigning the inputs/outputs**, the order is arbitrary. All inputs/outputs can be assigned to the measurement places MPx unordered and mixed.



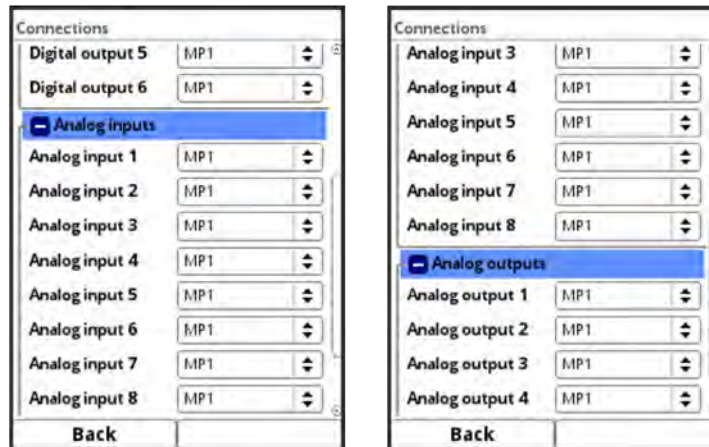

Fig. 45-4 Assignment Examples Inputs/Outputs

Furthermore, it is possible to assign inputs and outputs to the virtual combi measurement place (Combi). For example, an analogue input for the consideration of an external flow measurement as a fourth measurement place and/or an analogue output for the output of the total flow.

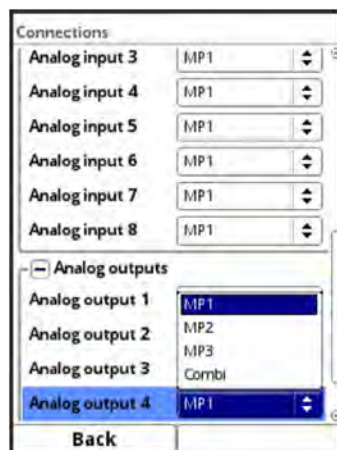

Fig. 45-5 Assigning Inputs/Outputs to the Combi Measurement Place

- ➡ After assigning the inputs and outputs to the corresponding measurement places, the final parameterisation of the individual measurement places is carried out according to Chap. "39 Parameter Description".

45.4 Baud Rate (all Types)

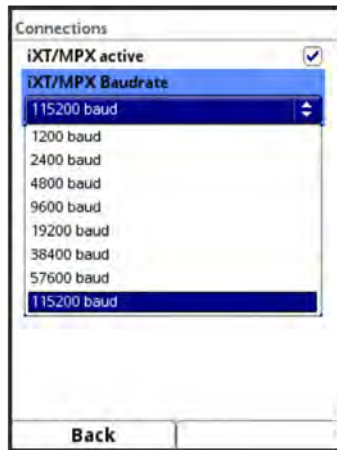

Fig. 45-6 Baud Rate

For all types, it is possible to change the **>Baud Rate<** here.

Default setting: 115200 Baud.



Consultation with the customer service required

Change the baud rate only after consultation with the NIVUS customer service.

Reduced baud rates make transmission more reliable, but slow down the response speed of the entire measurement system.

For long distances and therefore particularly long sensor cables, it may nevertheless be necessary to change the baud rate.

Diagnostics

46 Basics of the Diagnostics Menu



Fig. 46-1 Menu Diagnostics

The menu >Diagnostics< can be found in the >Application< menu. Diagnostics is divided into up to six submenus (six if the controller is activated).

The Diagnostics menu and all submenus are purely display and simulation menus. There is no parameterisation possible within the menu.

In this section, the following settings can be checked or simulated:

- **h-Sensors:**
Level currently used for calculation, the levels determined by the individual connected and parameterised level sensors as well as their adjustment heights.
Serial number, firmware version, echo profile and temperature of the i-Sensor.
Raw value, calibrated value and value used for calculation as well as firmware version, serial number, article number, echo profile and signal noise values of the water-ultrasonic sensor.
Raw value, calibrated value and value of the integrated pressure sensor used for calculation.
- **v-Sensors:**
Article numbers, firmware versions, serial numbers, determined average velocities, graphical velocity profile, tabular representation of the individual velocities and their height position, 3D animation of the prevailing velocity profile as well as various quality parameters of the measurement.
- **Inputs and Outputs:**
Status and (partly) simulation of the analogue and digital inputs and outputs.
- **Q-Controller:**
Indication of the current controller status, the currently prevailing flow value and level, setpoint used, deviation between setpoint and actual value, sampling time of the control algorithm, slider running time, error delay and the states of the parameterised digital inputs for control operation.
- **Flow profile:**
3D animation of the prevailing velocity profile in different views.
- **Simulation:**
Access to and change option for all internally recorded (level, velocity) and calculated values (flow rate) as well as to the digital and analogue signal outputs.



Important Notice

It is essential to follow the safety instructions for the simulation on Page 198.

47 Diagnostics h-Sensors

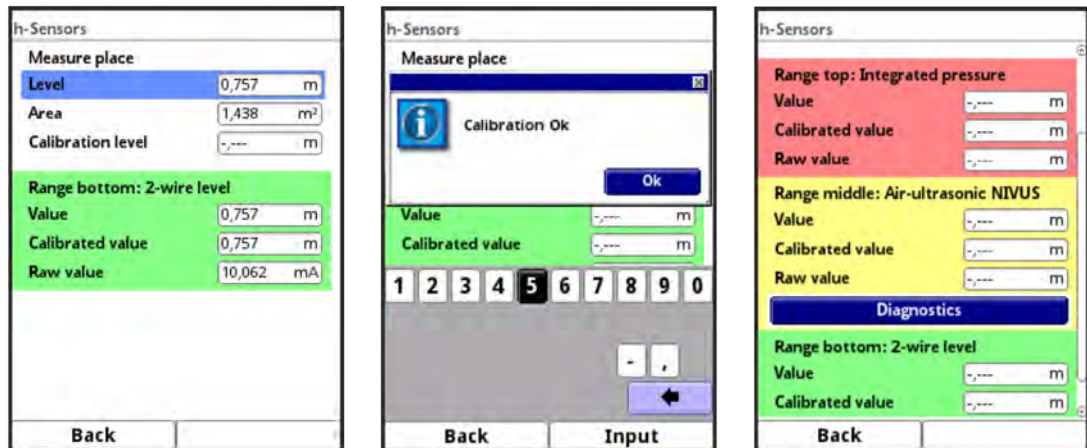

Fig. 47-1 Menu Diagnostics h-Sensors

This menu works in conjunction with the >Applications< / >h-Sensors< menu. Depending on the type and number of sensors defined there, 1...3 areas are displayed in colour.



See Chapter "39.2 Setting Parameters in Menu h-Sensors".

In >Diagnostics h-Sensors<, the current level and the currently wetted area, calculated on the basis of the channel shape/dimensions entered, are displayed unchangeably. The adjustment height can be set and is also confirmed with OK after entry (Fig. 47-1). The offset or a new mounting height is calculated from the adjustment height (depending on the sensor). Depending on which sensors are selected, the value, the calibrated value or the raw value is displayed.

- **Value:** currently used value
- **Calibrated value:** corrected value if an adjustment has been carried out
- **Raw value:** value actually measured by the sensor

For the sensor types "Water-Ultrasound integrated" and "i-Sensor", it is possible to obtain information on firmware version, serial and article number, various quality parameters of the measurement as well as the graphically displayed echo signal after pressing the button "Diagnostics".

With the i-sensor connected via HART, the prevailing sensor temperature (usually corresponding to the ambient temperature) can also be read and the sensor can be changed or reset in some sensor parameters.



Special Knowledge required

This function requires extensive knowledge in the application evaluation of the ultrasonic signal and should only be carried out by NIVUS service or by companies authorised by NIVUS.

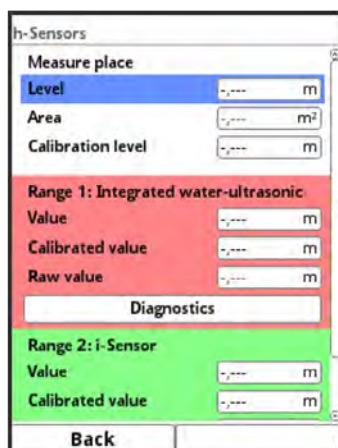

Fig. 47-2 Water-Ultrasonic Sensor

48 Diagnostics v-Sensors

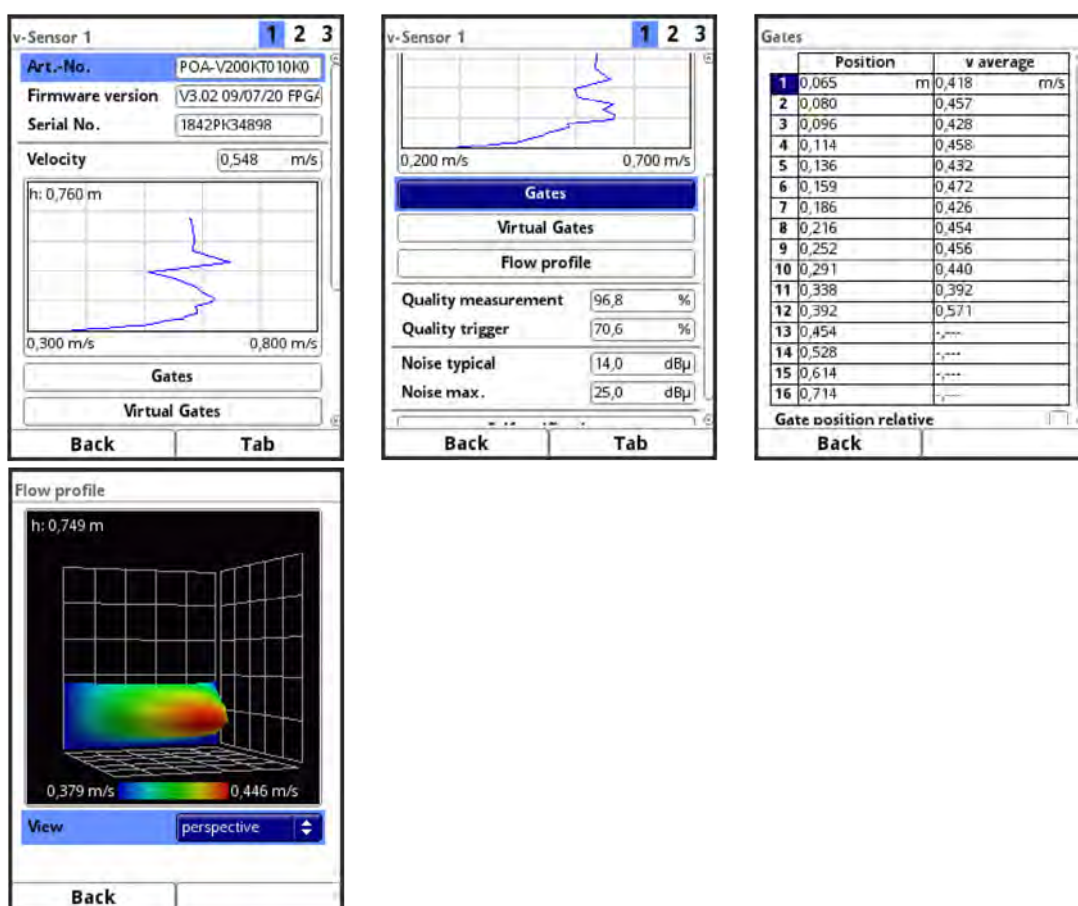

Fig. 48-1 Menu Diagnostics v-Sensors

In this menu, hardware information and current data on the sensors can be displayed (see Fig. 48-1).

In detail these are:

- Article number, firmware version and serial number (important for customer service in case of queries)
- Calculated average velocity
- Gates and virtual gates

- Flow profile
 - perspective
 - top
 - front
 - Page
- Quality Measurement and trigger
- Noise typical and maximum

The right function key (Tab) can be used to jump between the sensors.

The individual measured velocities and the corresponding filling levels can be displayed in tabular form:

- Rotate the rotary pushbutton until the field >Gates< is highlighted blue.
- Press the rotary pushbutton - the current information is displayed in tabular form.

Gates

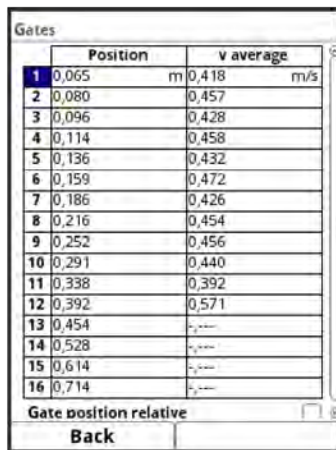

	Position	v average
1	0,065 m	0,418 m/s
2	0,080	0,457
3	0,096	0,428
4	0,114	0,458
5	0,136	0,432
6	0,159	0,472
7	0,186	0,426
8	0,216	0,454
9	0,252	0,456
10	0,291	0,440
11	0,338	0,392
12	0,392	0,571
13	0,454	-
14	0,528	-
15	0,614	-
16	0,714	-

Gate position relative

Back

Fig. 48-2 Gates

Here, the average height of the measured velocity gate, related to the 0-point of the application, is displayed in the "Position" column.

The column "v-average" contains the value of the corresponding measured and damped average velocity.

By checking >Gate position relative<, the gate positions are displayed relative to the position of the flow velocity sensor, regardless of the installation angle, installation position and installation height of the sensor.

Deviating display conditions in the gates table:

- Due to a minimum gate length required for signal purposes, 16 gates cannot be displayed for applications with **lower filling levels**. Therefore, in these cases, it is possible that the total number of gates in the table will be reduced.
- Velocities
 - directly **below the water surface**,
 - within the **block distance** ("dead zone") in front of the sensors and
 - **underneath the installation position** of the sonic converter in the sensor body cannot be determined by measurement and therefore cannot be presented here in tabular form.

Virtual Gates

Virtual Gates			
	Position	v virtual	v average
1	0,007 m	0,258 m/s	---
2	0,014	0,294	---
3	0,022	0,315	---
4	0,029	0,330	---
5	0,036	0,342	---
6	0,043	0,351	---
7	0,051	0,359	---
8	0,058	0,366	---
9	0,065	0,396	0,396
10	0,080	0,382	0,382
11	0,096	0,371	0,371
12	0,114	0,373	0,373
13	0,136	0,391	0,391
14	0,160	0,448	0,448
15	0,187	0,466	0,466
16	0,217	0,423	0,423
17	0,253	0,490	0,490

Virtual Gates			
15	0,188	0,562	0,562
16	0,219	0,603	0,603
17	0,255	0,626	0,626
18	0,295	0,663	0,663
19	0,343	0,638	0,638
20	0,397	0,593	0,593
21	0,461	0,616	0,614
22	0,536	0,647	0,655
23	0,623	0,630	---
24	0,638	0,626	---
25	0,653	0,626	---
26	0,667	0,625	---
27	0,682	0,625	---
28	0,697	0,625	---
29	0,712	0,624	---
30	0,726	0,624	---
31	0,741	0,623	---
32	---	---	---

Fig. 48-3 Virtual Gates

When selecting and displaying virtual gates, a maximum of 32 gates are displayed. That is 8 calculated gates above the maximum measurable gate up to the measured water surface and 8 calculated gates below the last measurable gate up to the parameterised 0-point of the channel/pipe. The other, maximum 16, measurable gates are located between the two calculated gate areas.

If the level in the application is too low, it is not possible to measure 16 gates. In this case, the 32 gates are reduced by the number of gates that cannot be measured. The number of the 8 calculated gates above and below the measurable range remains constant. If there are invalid gates within the measurable range, they are replaced by the same integrated mathematical model that calculates the gates above and below the measurable range.

The 8 calculated gates above and below the measurement range are divided symmetrically. The positions of the measurable gates are subject to a mathematical algorithm.

The flow profile is calculated according to internal hydraulic methods. The following factors are included in this calculation of the flow profile:

- Individual velocities
- Individual heights
- Channel profile
- Channel dimensions

The display can be switched between front view, top view, front view, side view or a perspective view. The values are scaled automatically.

Anomalies in the velocity distribution can only be plausibly visualised when using more than one flow velocity sensor at a flow measurement point. With their use, horizontal hydraulic disturbances also become visible.

This 3D animation is therefore particularly useful when using multiple v-sensors (only for NivuFlow 750 Type M3/G3/M9/G9). In structured flow profiles and behind hydraulic disturbances such as bends or channel profile changes, it allows for a quick initial assessment of the expected flow conditions and the resulting hydraulic challenges.

Quality Parameters

Four fields show the quality of the measurement (comparable to a signal strength), the quality of the trigger (correspondence of the equality of signal images) as well as the typical and maximum noise of the signal cable.

In the event of measurement problems, they represent important initial diagnostic parameters for the NIVUS service or the specialist companies authorised by NIVUS. They are not relevant for the normal operation of the transmitter and are therefore not explained in detail here.



Using the Quality Parameters determined here

The information on the measurement and trigger quality as well as the signal cable noise is important for the NIVUS commissioning and service personnel.

49 Diagnostics Inputs and Outputs (analogue and digital)

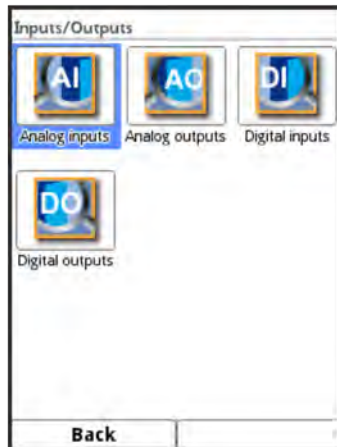

Fig. 49-1 Menu Diagnostics Inputs/Outputs

➡ See also Chapter “39.4 Setting Parameters of Inputs and Outputs (analogue and digital)”.

49.1 Analogue Inputs

In this menu, the current values present at the analogue inputs of the transmitter can be displayed as mA values as well as the measured values (assigned by means of the measuring span parameterised in the transmitter).

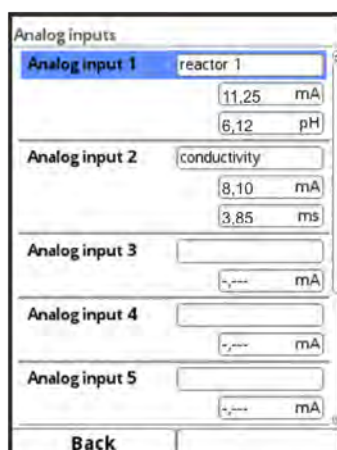

Fig. 49-2 Display of analogue Input Values

With this display, the presence of an external signal and its correct value can be checked without using a measurement device. The immediate conversion into the parameterised measurement span enables the plausibility of the measured value to be checked as well as the correct parameterisation of the input span.

49.2 Analogue Outputs

In this menu, the calculated current values to be output at the analogue transformer and the measured values (assigned by means of measurement span) are displayed. A password-protected simulation of the individual analogue values is also possible.

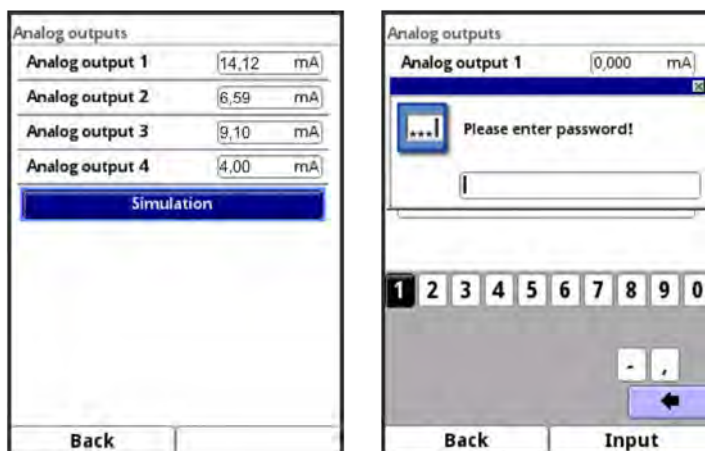

Fig. 49-3 Display of analogue Output Values



The actual flowing currents are not output.

The display only shows the signal that the analogue output converter receives for output. An external faulty circuit or a defective D/A converter cannot be detected and displayed.

DANGER



Personal injury or property damage

The simulation of the analogue outputs shall only be carried out by qualified electricians. These specialists must have precise knowledge of the entire regulation and control process of the system.

Prepare the simulation in detail:

- *Switch the following equipment to manual operation.*
- *Switch off the actuators etc. or limit their function.*

A safety person is absolutely necessary during the performance!

Disregarding may result in personal injury or damage to the system.

Due to the extremely high risk potential and the incalculable consequences of inadequate or incorrect simulation or disregard of the safety instructions, NIVUS hereby decline any responsibility whatsoever for any personal injury or damage to property in any amount!

DANGER



Effect on Plant Sections

A simulation of the NivuFlow outputs directly accesses all following plant sections without any safety interlock!

Simulations shall only be carried out by qualified personnel.

Be sure to observe the preceding warning!



Note

For the previously mentioned safety reasons, access to the simulation is protected by a password.

To protect yourself, only pass on the password to authorised and instructed specialist personnel!



To simulate an analogue output, proceed as follows:

1. Enter the password
2. Rotate the rotary pushbutton until the desired analogue output is highlighted blue.
3. Press the rotary pushbutton - the analogue output is activated by a tick.
4. Then enter the desired output current as a numerical value.
Make sure that the analogue outputs continue to supply the entered current values until the simulation menu is closed again.
5. Press the left function key to exit the simulation menu.

49.3 Digital Inputs

This menu shows the signals present at the digital inputs.

All available digital inputs (according to the transmitter type) are always displayed, regardless of their activation. The parameterised function of the digital input is shown in brackets after "DI xx".

Inactive digital inputs are identified by the designation "(In. inact.)".

The status of the digital inputs (depending on "inverted"/"not inverted") is indicated by a tick/no tick following the name of the input.

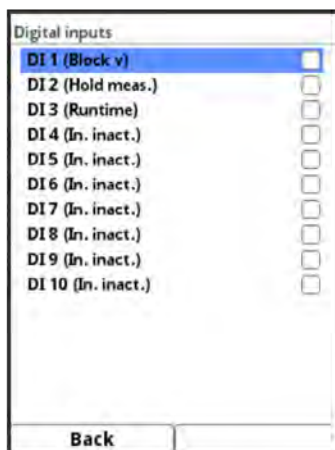

Fig. 49-4 Display of digital inputs

49.4 Digital Outputs

The digital output values available at the transmitter are displayed in this menu. All available digital outputs (according to the transmitter type) are always displayed, regardless of their activation. The parameterised function of the digital output is shown in brackets after "DO xx".

Inactive digital outputs are identified by the designation "(Out inact.)".

The status of the digital outputs (depending on "inverted"/"not inverted") is indicated by a tick/no tick following the name of the output.

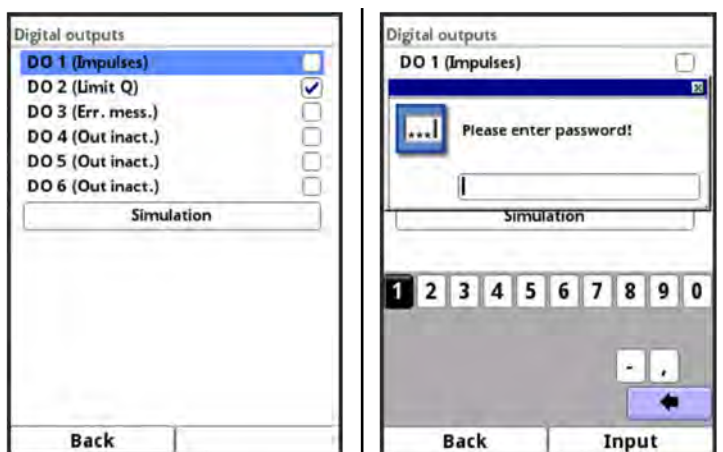

Fig. 49-5 Display of digital outputs

A password-protected simulation of the digital outputs is also available in this menu.

DANGER



Personal injury or property damage

The simulation of the digital outputs shall only be carried out by qualified electricians. These specialists must have precise knowledge of the entire regulation and control process of the system.

Prepare the simulation in detail.

- *Switch the following equipment to manual operation.*
- *Switch off the actuators etc. or limit their function.*

A safety person is absolutely necessary during the performance!

Disregarding may result in personal injury or damage to the system.

Due to the extremely high risk potential and the incalculable consequences of inadequate or incorrect simulation or disregard of the safety instructions, NIVUS hereby decline any responsibility whatsoever for any personal injury or damage to property in any amount!

DANGER



Effect on Plant Sections

A simulation of the NivuFlow outputs directly accesses all following plant sections without any safety interlock!

Simulations shall only be carried out by qualified personnel.

Be sure to observe the preceding warning!



Note

For the previously mentioned safety reasons, access to the simulation is protected by a password.

To protect yourself, only pass on the password to authorised and instructed specialist personnel!

➡ To simulate a digital output, proceed as follows:

1. Enter the password.
2. Rotate the rotary pushbutton until the desired digital output is highlighted blue.
3. Press the rotary pushbutton - the digital output is activated by a tick.

4. Then enter the desired output current as a numerical value.
Make sure that the digital outputs continue to supply the entered current values until the simulation menu is closed again.
5. Press the left function key to exit the simulation menu.

Activating the simulation of each output is done in the same way.

50 Diagnostics Flow Controller (Q-Controller)

The controller menu is a read-only menu. It is not possible to intervene or to simulate here.



Fig. 50-1 Flow Controller (Q-Controller)

According to the previously made settings, the currently calculated **Flow** and the **Level** used for this are displayed in controller mode.

The setpoint display corresponds to the **Setpoint** set in the parameter. When using an external, variably adjustable setpoint, the currently used setpoint is displayed.

The **(Control) Deviation** results from the setpoint used and the actual value. This deviation is "frozen" at the beginning of the scanning time and the controller operates with this value during the entire scanning time.

The **Sample time** represents the rhythm in which the controller outputs a possible new control command (cycle time). The display shows the remaining sample time until the next output.

The valve run time is the calculated travel time of the valve (CLOSE/OPEN). According to the parameterised controller function and depending on the control deviation, this time becomes longer or shorter.

The direction of the valve run time is shown on the **Valve CLOSE/OPEN** fields below. The tick is only visible as long as the corresponding relay is activated.

Reaching the respective **End CLOSE/OPEN** switch is indicated by a tick in the boxes below.

In the event of an error, the controller normally goes into a programmable error mode. This transition can be delayed to hide/ignore brief error messages. When an error occurs, the error runtime starts to run up until it has reached the set time for the transition to error mode. This run-up time is visible under **Error Delay**. If the error message disappears during this set time, the error delay display jumps back to "0".

If the torque switch responds "CLOSED", this is indicated by a tick in the **Torque** box.

External manual operation via a parameterised digital input is indicated by a tick in the **Manual** box.

51 Diagnostics Flow Profile

This diagnostic menu displays a coloured, three-dimensional flow profile of the measurement place based on the parameterised shape and its dimensions. Here, the individual flow velocity ranges are spatially displayed from the colour blue (standing to slow flow velocity) through green (medium flow velocity) and yellow to red (fast flow velocity).

The calibration of the axes is exclusively automatic and adapts to changing speeds. A colour scale with the minimum and maximum values below the display facilitates the assessment. The display can be switched between >perspective<, >top<, >front< and >side<.

The menu allows a first visual impression of the hydraulics at the measurement place, especially when using several flow velocities in larger channel dimensions. For this purpose, the measured individual velocities and the current filling level are transferred to a 3D model with the dimensions of the measurement place for quick graphical representation using simplified mathematical models and output graphically.



Information on the flow velocity profile

The graphical representation of the flow velocity profile is a simplified visualisation. It does not always correspond exactly to the actual hydraulic conditions.

The generation and visualisation of the flow velocity profile on the display is based on simple mathematical formulas. It serves only as initial visual information. There is no hydraulic reference to the parameterised measurement place.

The integrated CFD models and hydraulic calculations of the velocity models are not included or shown.

For example, asymmetrically or off-centre positioned flow velocity sensors - especially single sensors - can lead to seemingly implausible flow velocity representations. Special designs, dry weather channels, egg-shaped profiles and trapezoidal channels and similar cannot be visualised or cannot be visualised hydraulically correct by using the simplified representation.

For exact representation and allocation of the measured individual velocities, the menu >Application< / >Diagnosis< / >v-Sensors< is recommended.

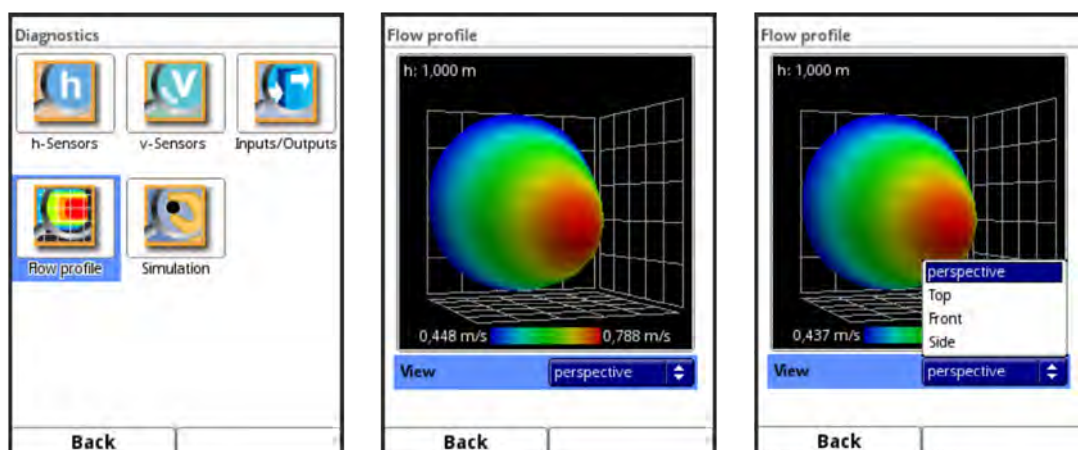

Fig. 51-1 Diagnostics Flow Profile

52 Diagnostics Simulation

In this menu, a theoretical flow can be simulated by manually entering fictitious fill level and flow velocity values in the parameterised application.

The transmitter uses these simulated values - based on the dimensions of the parameterised channel - to calculate the prevailing flow value.

This value is output at the previously defined analogue and digital outputs, Modbus and HART if available according to the parameter settings made.

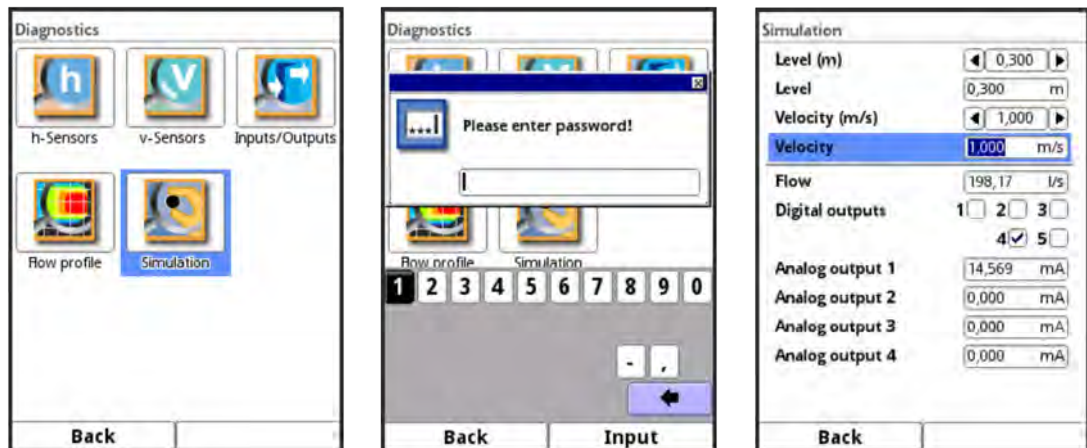

Fig. 52-1 Diagnostics / Simulation

DANGER



Personal injury or property damage

The simulation shall only be carried out by qualified electricians. These specialists must have precise knowledge of the entire regulation and control process of the system.

Prepare the simulation in detail.

- Switch the following equipment to manual operation.
- Switch off the actuators etc. or limit their function.

A safety person is absolutely necessary during the performance!

Disregarding may result in personal injury or damage to the system.

Due to the extremely high risk potential and the incalculable consequences of inadequate or incorrect simulation or disregard of the safety instructions, NIVUS hereby decline any responsibility whatsoever for any personal injury or damage to property in any amount!

DANGER



Effect on Plant Sections

A simulation of the NivuFlow outputs directly accesses all following plant sections without any safety interlock!

Simulations shall only be carried out by qualified personnel.

Be sure to observe the preceding warning!

**Note**

For the previously mentioned safety reasons, access to the simulation is protected by a password.

To protect yourself, only pass on the password to authorised and instructed specialist personnel!

➔ Procedure for the simulation:

1. Enter the password.
2. Turn the rotary pushbutton until the desired value to be simulated (level or velocity) is highlighted in blue.
3. Activate the field by pressing the rotary pushbutton and enter the desired measurement value.
Either at **Level [m]** or **Velocity [m/s]** by rotating the rotary pushbutton in 1/1000 steps or at **Level** or **Velocity** with direct entry of the value.
4. Confirm entry with the right function key.
The **Flow** field automatically displays the flow rate value calculated by the two simulated level/speed values.
Any parameterised digital/analogue outputs behave as if they were actually parameterised and output these values in real terms.
These output signals and values are shown on the display.
5. Press the left function key to exit the simulation menu.

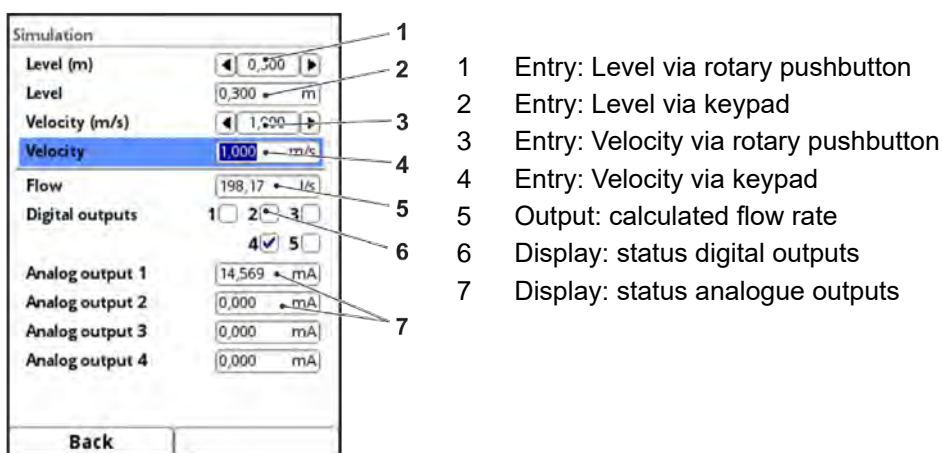

Fig. 52-2 Display of calculated values and output states

Maintenance and Cleaning

WARNING***Disconnect the System from Mains Power***

*Disconnect the unit from the mains and secure the higher system against being switched on again before starting maintenance.
Disregarding may lead to electric shock.*

WARNING***Germ Contamination***

Due to the frequent use of the sensors in the waste water sector, parts can be contaminated with dangerous germs. Therefore, appropriate precautions must be taken when coming into contact with cables and sensors.

Wear protective clothing.

53 Maintenance

53.1 Maintenance Interval

The Type NivuFlow transmitter is virtually free of calibration, maintenance and wear by design. Nevertheless, NIVUS recommend **an annual check** of the entire measuring system by the NIVUS customer service.

Depending on the area of application of the measuring system, the maintenance interval may vary.

The scope of maintenance and its intervals depend on the following factors:

- Measurement principle of the level sensors
- Material wear
- Measurement medium and channel hydraulics
- General regulations for the operator of the measurement system
- Environmental conditions

NIVUS recommends having the measurement system completely be inspected by a company of the NIVUS group **after latest ten years**.

Generally the verification of instruments and sensors is a basic measure in order to improve operational reliability and to increase the lifetime.

53.2 Customer Service Information

For the recommended annual inspection of the entire measuring system or complete maintenance after ten years at the latest, contact our customer service:

NIVUS GmbH - Customer Centre

Phone +49 7262 9191-922

customercenter@nivus.com

54 Cleaning

54.1 Transmitter

WARNING



Disconnect the System from Mains Power

Make sure that the transmitter is disconnected from mains power.

Disregarding may lead to electric shock.



Important Notes

- The **blue plastic strips** of the DIN rail enclosures must not be removed for cleaning the enclosure.
- **Never wipe the terminal blocks or plug connections** with a damp cloth or similar.

If necessary, clean the transmitter enclosure with a dry lint-free cloth.

In case of heavier dirt, you can wipe the enclosure with a damp cloth. Do **not** use harsh cleaning agents or solvents. Instead, it is better to use mild household cleaners or soap suds.

54.2 Transducers

Be sure to follow the instructions for maintenance and cleaning of the sensors. These instructions can be found in the respective technical description or instruction manual.

The technical description or operating instructions are part of the sensor delivery or can be downloaded at www.nivus.com.

55 Dismantling/Disposal

Improper disposal may be harmful to the environment.

- ➡ Dispose of device components and packaging materials in accordance with the applicable local environmental regulations for electrical products:

1. Disconnect the device from mains power.
2. Disconnect connected cables on the front of the device with a suitable tool.
3. Remove the transmitter from the DIN rail.
4. Remove the buffer battery (coin cell) from the transmitter (see procedure described as follows) and dispose of it separately and properly.



EU WEEE Directive

This symbol indicates that the requirements of Directive 2012/19/EU on waste electrical and electronic equipment must be observed when disposing of the device. NIVUS GmbH support and promote the recycling or environmentally sound, separate collection/disposal of waste electrical and electronic equipment to protect the environments and human health. Observe the local laws and regulations on disposal.

NIVUS GmbH is registered with the EAR, therefore public collection and return points in Germany can be used for disposal.

The device is equipped with a buffer battery (lithium button cell) that must be disposed of separately.

➡ Procedure for removing the buffer battery (coin cell) on the removed transmitter:

1. If present, remove the four blue plastic strips (Pos. 1). These are plugged in and glued to the basic unit.

Info:

If the transmitter was installed in a field housing, these plastic strips are not present.

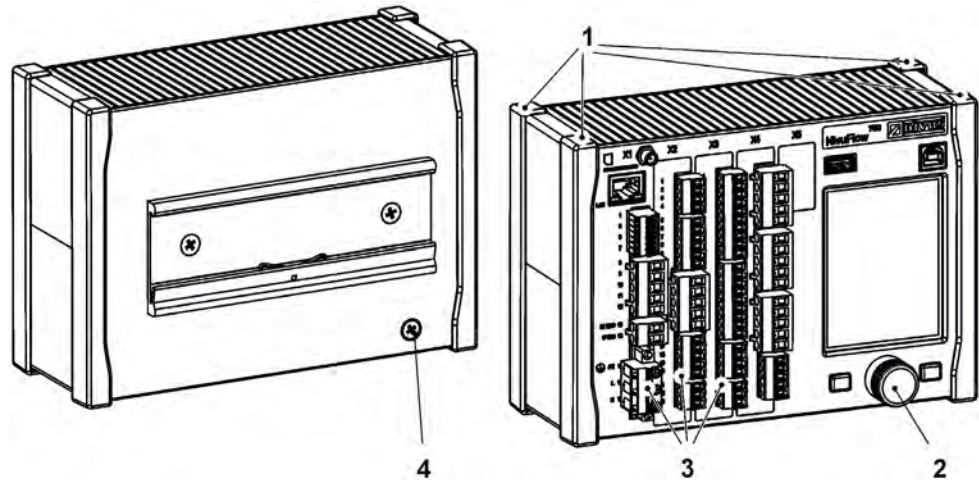

2. Remove the cover cap (Pos. 2) on the rotary pushbutton with a screwdriver or similar.
3. Loosen the fastening inside the rotary push-button with a screwdriver or similar.
4. Unscrew the countersunk screw M4x8 (Pos. 4) (for earthing/fastening) incl. serrated lock washer on the back of the housing.
5. Pull off the rotary pushbutton and existing connector strips (Pos. 3) from the front of the enclosure.
6. Unscrew 4x M3 Torx self-tapping screws on the front of the enclosure (previously covered by the plastic strips) and remove the front panel together with the circuit boards.



7. Remove the buffer battery (Pos. 5) mounted on the upper board.

56 Installation of Spare Parts and Wearing Parts

We expressly draw your attention to the fact that spare parts and accessories which have not been supplied by us have also not been tested and approved by us.

The installation or use of such products may therefore negatively alter or invalidate the design properties of your measurement system.

NIVUS are expressly excluded from liability for damage caused by the use of non-original parts and non-original accessories.



You will find a selection of the accessories of the NIVUS GmbH in Chapter "57 Accessories".

57 Accessories

Article No	Description
<i>iXT0 xxx</i>	Intelligent Ex Separation Module for Ex-safe connection of the sensors
<i>MPX0 421</i>	Multiplexer/line driver for RS485 sensors in non-Ex areas
<i>ZUB0 USB STICK</i>	USB stick for readout of parameters and readings
<i>SW0 NS PRO</i>	Evaluation software, NivuSoft Professional with coordinated functions: Measurement place documentation, graphical and tabular output, creation of statistics/reports, etc.
<i>BSL0 xx</i>	Various overvoltage protection elements for power supply, sensors and data lines of the transmitter
<i>ZUB0 NFWx</i>	Field enclosure in different versions to protect the NivuFlow in outdoor areas
<i>NFX0 LIZENZ ERW</i>	Device licence for activation: transmission activation of the "Advanced" data set (transmission of the "Standard" data set works without licence)
<i>NFX0 LIZENZ EXP</i>	Device licence for activation: transmission activation of the "Expert" data set (transmission of the "Standard" data set works without licence)
<i>NFX0 LIZENZ FTP</i>	Device licence for activation: remote data transmission via FTP and E-Mail (required if a customer SIM card is used)
<i>NFX0 LIZENZ MODB</i>	Device licence for activation: Modbus coupling of up to 3x NF5, NF6 and NF7 to one multi-measurement place device NF7-5G9....2/3
<i>NFX0 LIZENZ PWDN</i>	Device licence for activation: clocked operation of permanent NivuFlow transmitters

Tab. 12 Accessories (selection) for the transmitter NivuFlow 750/700



Further information on spare parts and accessories can be obtained from your responsible distributor/agency or directly from the NIVUS GmbH.

Index

Symbole

>Browse< Function 141

A

Accessories 203
 Accident Levels 15
 Advance Main Display
 NF 750 M9/G9 179
 Air temperature
 Analogue Output 124
 Analogue Input
 Diagnostics 192
 Analogue Output
 Diagnostics 193
 Approvals 209
 Article No 28

B

Backlight 179
 Backup Battery 201
 Basic Menu 79
 Baud Rate
 Connections 186
 Block v-Measurement
 Digital Input 126

C

Cable cross-sections 41
 Calming Section 48
 CE Label 25
 Certificates 209
 Change Password 89
 Chemicals 38
 Clock Control
 Data Memory 150
 Communication
 HART 176
 Modbus 177
 TCP/IP 167
 Web Server 168
 Compress 146
 Connections 12, 19
 Contact Protection Measures 48
 Control Elements 12, 13, 75
 Control Threshold
 Q-Controller 135
 Copyrights 3
 Cross Correlation 31

Current Measurement Data 140
 Customer Centre 200
 Cycle Mode
 Data Memory 150

D

Data Depth
 Expert 146
 Extended 145
 Standard 145
 USB Stick 145
 Data Memory 27
 Data Transmission
 E-Mail 173
 FTP 171
 MQTT 170
 Date/Time Selection 140
 Device ID 25
 Device Structure 22
 Digital Input
 Diagnostics 194
 Digital Output
 Diagnostics 194
 Disclaimer 17
 Display
 Overview 75
 Disposal 201

E

Electrostatic Discharge 36
 Environmental Regulations 201
 Error Delay
 Q-Controller 136
 Error Message
 Digital Output 132
 Error Runtime
 Q-Controller 136
 ESD 36
 ESD Risks 36
 EU WEEE Directive 201
 Event Interval
 Cycle/Clock Control Operation 153
 External Measurement Value
 Analogue Output 124

F

File Naming 148
 Flow
 Analogue Output 124
 Flow distribution 32

- Flow profile 32
 asymmetric 33
 Diagnostics 197
 Flow Velocity
 Analogue Output 124
 Flush with Wall 112
- G**
 Gases 38
 Germs 16, 200
- H**
 Hand over the Instruction Manual 19
 HART
 Analogue Output 125
 Communication 176
 h-crit
 Low Levels 119
 h-crit automatic
 Low Levels 119
 h-manual
 Low Levels 119
 Hotline 74
 Humidity 21, 26
- I**
 Impulse Counter
 Digital Input 127
 Input Correction 78
 Inspection upon Receipt 21
 Installation Instructions 40
 Instruction Manual 21
 Intended Use 18
 Interfaces 14, 22
- K**
 Keep the Instruction Manual for future
 Reference 19
 Keypad 77
- L**
 Language 158
 Operation 158
 Level
 Analogue Output 124
 Level Sensor
 Analogue Output 124
 Level Sensors
 Selection 104
 Limit Contact Air Temperature
 Digital Output 131
 Limit Contact External Measurement
 Value
 Digital Output 131
 Limit Contact Flow
 Digital Output 129
 Limit Contact Level
 Digital Output 130
 Limit Contact Sludge
 Digital Output 131
 Limit Contact Velocity
 Digital Output 130
 Limit Contact Water Temperature
 Digital Output 131
 Load Parameters 148
 Logging
 Digital Input 127
 Low Voltage Network 47
- M**
 Main Menu 89
 Materials Disposal 19
 Maximum Q
 Q-Controller 135
 Max. On Time
 Q-Controller 136
 Measurement span 33
 Measurement windows 32
 Min. On Time
 Q-Controller 136
 Modbus
 Communication 177
 Modbus Slave
 Analogue Output 125
 Digital Output 133
 Mode of Operation
 Cycle/Clock Control 151
 Modifications 4
 Mounting Instructions 36
 Mounting Place 36
- N**
 Nameplate 25
 Names 3
 Negative offset 33
 Notes on Use 74
 Numeric field 78
- O**
 Operating Conditions 26
 Operation Temperature 26
 Operator's Duties 19
 Original manufacturer parts 202

Output Fields 180
 Overview
 Product..... 22
 Overvoltage Category 26
 Overvoltage Protection Elements..... 49

P

Period 140
 P-Factor
 Q-Controller..... 135
 Piezoresistive 35
 Pollution Degree..... 26
 Power Consumption..... 26
 Power Supply 26
 Precautions 16
 Product Construction..... 22
 Product Disposal 19
 Property Rights 3
 Protection 26
 Protection Class 26
 Protective earth connection..... 16

Q

Q-Controller
 Diagnostics..... 196
 Q-Factor
 Q-Controller..... 137
 Q-Quick Close
 Q-Controller..... 136
 Q suppressed
 Low-Flow..... 101
 Qualified Personnel..... 20, 74
 Quick Close Runtime
 Q-Controller..... 137

R

Radioactive radiation..... 38
 RCD 40
 reflect 31
 Reflection pattern 31
 Relative pressure principle 35
 Reset
 Measurement 164
 Parameters..... 164
 Residual Current Device 40
 Restart
 Measurement 164
 System 164
 Return 21
 Runtime
 Digital Input 127

Runtime from Pos. Close
 Q-Controller..... 136

S

Safety Instructions..... 15
 Sample Time
 Q-Controller..... 135
 Save Parameters 148
 Scope of Delivery 21
 Scrapping 201
 Sensor Velocity
 Analogue Output 124
 Setpoint Modbus
 Q-Controller..... 135
 Setpoint w
 Q-Controller..... 135
 Shocks 21
 Signal Words 15
 Simulation
 Diagnostics..... 198
 Slider OPEN
 Digital Output 133
 Slider Runtime
 Q-Controller..... 136
 Sludge Level
 Analogue Output 124
 SNTP
 Time Server..... 161
 Spare Parts 202
 Spare Parts Orders 25
 Specifications 26
 Storage Cycle..... 27
 Basic Functions..... 149
 Cycle/Clock Control..... 153
 Storage Temperature..... 26
 Sum Impulses
 Digital Output 129
 Sunlight 38
 Symbols 15
 System Time 161

T

TCP/IP
 Communication 167
 Temperature 21
 Theoretical Flow
 Simulation 198
 Time Zone 161
 Totalising 144
 Transducers 27
 connectable..... 24
 Translation..... 3

Transmission Period	
USB Stick	144
Transport	21
Transport Damage	21
Trend Graph	81

U

Ultrasound reflection principle	31
Units System	159, 160
Use	18

V

v-crit	
Low Levels	119
v-Determination Automatic	
Low Levels	118
Vibrations	21
v-manual	
Low Levels	119
v suppressed	
Low-Flow	102

W

Warning Notice on the Device	16
Warranty	17
Water Temperature	
Analogue Output	124
Water-ultrasonic combi sensor	34
Wearing Parts	202
Web Server	
Communication	168

Open Source Software

58 List of Sources of the Licences and Codes used

The transmitter type NivuFlow uses code from the following open source projects:

- Freetype (<http://www.freetype.org>)
- Libharu (<http://libharu.org>)
- Libjpeg (<http://www.ijg.org>)
- Libpng (<http://www.libpng.org>)
- Zlib (<http://www.zlib.net>)
- Mini-XML (<http://www.msweet.org>)
- Nano-X/nxlib (<http://www.microwindows.org>)
- FLTK (<http://www.ftk.org>)
- Appendix1: LGPL
- Appendix2: MPL



Licensing Issues

For questions on licensing contact opensource@nivus.com

Approvals and Certificates

DE / EN / FR

EU Konformitätserklärung*EU Declaration of Conformity**Déclaration de conformité UE*

Für das folgend bezeichnete Erzeugnis:

*For the following product:**Le produit désigné ci-dessous:*

NIVUS GmbH
Im Täle 2
75031 Eppingen

Telefon: +49 07262 9191-0
Telefax: +49 07262 9191-999
E-Mail: info@nivus.com
Internet: www.nivus.de

Bezeichnung:	Durchflussmessumformer stationär NivuFlow 7xx / Energy Saver
<i>Description:</i>	<i>permanent flow measurement transmitter</i>
<i>Désignation:</i>	<i>convertisseur de mesure de débit fixe</i>
Typ / Type:	NF7-... / NR7-...

erklären wir in alleiniger Verantwortung, dass die auf dem Unionsmarkt ab dem Zeitpunkt der Unterzeichnung bereitgestellten Geräte die folgenden einschlägigen Harmonisierungsvorschriften der Union erfüllen:

we declare under our sole responsibility that the equipment made available on the Union market as of the date of signature of this document meets the standards of the following applicable Union harmonisation legislation:

nous déclarons, sous notre seule responsabilité, à la date de la présente signature, la conformité du produit pour le marché de l'Union, aux directives d'harmonisation de la législation au sein de l'Union:

- 2014/30/EU
- 2014/35/EU
- 2011/65/EU

Bei der Bewertung wurden folgende einschlägige harmonisierte Normen zugrunde gelegt bzw. wird die Konformität erklärt in Bezug die nachfolgend genannten anderen technischen Spezifikationen:

The evaluation assessed the following applicable harmonised standards or the conformity is declared in relation to other technical specifications listed below:

L'évaluation est effectuée à partir des normes harmonisées applicable ou la conformité est déclarée en relation aux autres spécifications techniques désignées ci-dessous:

- EN 61326-1:2013
- EN 61010-1:2010 + A1:2019 + A1:2019/AC:2019

Diese Erklärung wird verantwortlich für den Hersteller:

This declaration is submitted on behalf of the manufacturer:

Le fabricant assume la responsabilité de cette déclaration:

NIVUS GmbH
Im Täle 2
75031 Eppingen
Allemagne

abgegeben durch / represented by / faite par:

Ingrid Steppe (Geschäftsführerin / Managing Director / Directeur général)

Eppingen, den 21.10.2022

Gez. *Ingrid Steppe*



EU Konformitätserklärung

EU Declaration of Conformity

Déclaration de conformité UE

NIVUS GmbH
Im Täle 2
75031 Eppingen

Telefon: +49 07262 9191-0
Telefax: +49 07262 9191-999
E-Mail: info@nivus.com
Internet: www.nivus.de

Für das folgend bezeichnete Erzeugnis:

For the following product:

Le produit désigné ci-dessous :

Bezeichnung:	Durchflussmessumformer stationär mit internem 2G/3G/4G Modem zur Datenfernübertragung NivuFlow 7xx/Energy Saver
<i>Description:</i>	<i>Permanent flow measurement transmitter with internal modem for remote data transmission</i>
<i>Désignation :</i>	<i>Transmetteur de débit stationnaire avec modem intégré pour transmission de données</i>
Typ / Type:	NF7-xG... / NR7-xG...

erklären wir in alleiniger Verantwortung, dass die auf dem Unionsmarkt ab dem Zeitpunkt der Unterzeichnung bereitgestellten Geräte die folgenden einschlägigen Harmonisierungsvorschriften der Union erfüllen:

we declare under our sole responsibility that the equipment made available on the Union market as of the date of signature of this document meets the standards of the following applicable Union harmonisation legislation:

nous déclarons, sous notre seule responsabilité, à la date de la présente signature, la conformité du produit pour le marché de l'Union, aux directives d'harmonisation de la législation au sein de l'Union :

- 2014/53/EU
- 2011/65/EU

Bei der Bewertung wurden folgende einschlägige harmonisierte Normen zugrunde gelegt bzw. wird die Konformität erklärt in Bezug auf die nachfolgend genannten anderen technischen Spezifikationen:

The evaluation assessed the following applicable harmonised standards or the conformity is declared in relation to other technical specifications listed below:

L'évaluation est effectuée à partir des normes harmonisées applicable ou la conformité est déclarée en relation aux autres spécifications techniques désignées ci-dessous :

- EN 61010-1:2010 + A1:2019 + A1:2019/AC:2019
- EN 61326-1:2013
- EN 301 489-52 V1.3.1 (LTE/4G)
- EN 301 908-1 V15.2.1 (UMTS/3G, LTE/4G)
- EN 301 908-13 V13.3.1 (LTE/4G)
- EN IEC 62311:2020
- EN 301 489-1 V2.2.3
- EN 301 511 V12.5.1 (GSM/2G)
- EN 301 908-2 V13.1.1 (UMTS/3G)
- EN 18031-1:2024

Diese Erklärung wird verantwortlich für den Hersteller:

This declaration is submitted on behalf of the manufacturer:

Le fabricant assume la responsabilité de cette déclaration :

NIVUS GmbH
Im Täle 2
75031 Eppingen
Germany

abgegeben durch / *represented by / faite par :*

Udo Steppe (Geschäftsführer / *Managing Director / Directeur général*)

Eppingen, den 27.08.2025

Gez. *Udo Steppe*